

LOOPZ™

THE MEMORY GAME THAT GETS YOU MOVING!

PlayLoopz.com

AGES
7+
PLAYERS
1-4

Get ready to master your memory, rock your reflexes and tune up your timing! When Loopz™ plays changing patterns of light and music, all you have to do is repeat them by waving your hands through the matching loops – you don't need to touch anything! Different game modes will even let you create your own music!

So, if you think you're ready to rock, make your move with Loopz™!

Contents:

- 1 Loopz™ Tower
- 2 Circular Stands
- Instructions

Keep these instructions for future reference as they contain important information.

Requires 4 "AA" alkaline batteries.

Batteries included are for demonstration purposes only. Dispose of batteries safely.

THE LOOPZ™ TOWER

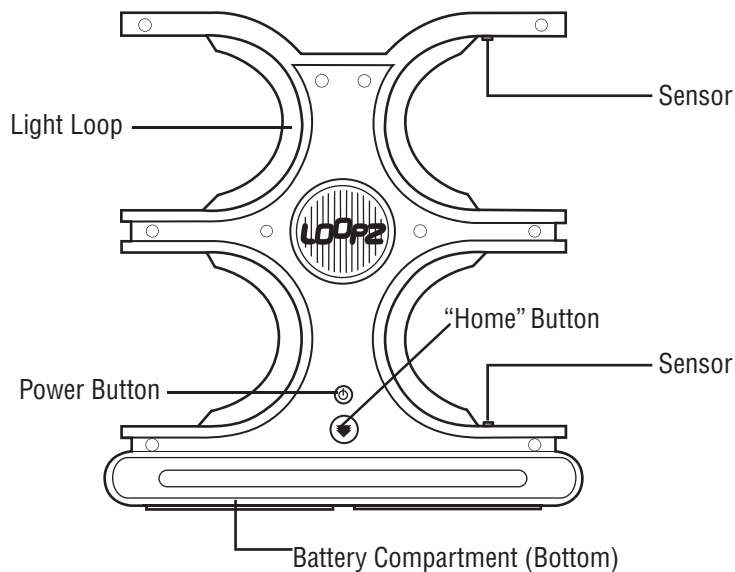

BATTERY INSTALLATION

1. Open battery cover with Phillips head screwdriver (not included).

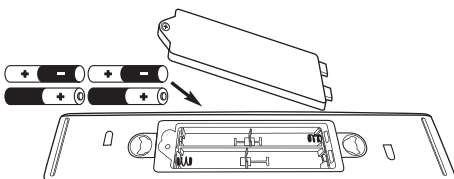

Bottom of Console

2. Install 4 new 'AA' alkaline (LR6) batteries in the orientation (+/-) shown.
3. Replace battery cover and tighten the screw.

For best performance, use only alkaline batteries.

Replace batteries when lights dim or sounds become distorted.

ASSEMBLY

1. Attach the two stands to the base of the Loopz™ tower by plugging their pins into the sockets on the tower's base.

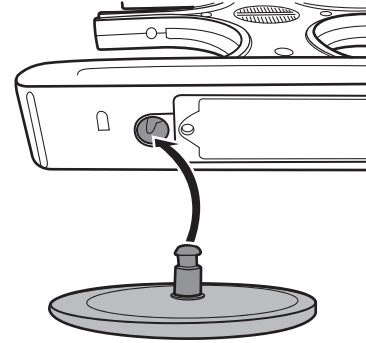

LET'S ROCK!

The First Time You Play

If it is there, remove the pull-tab from the slot on the back of the tower.

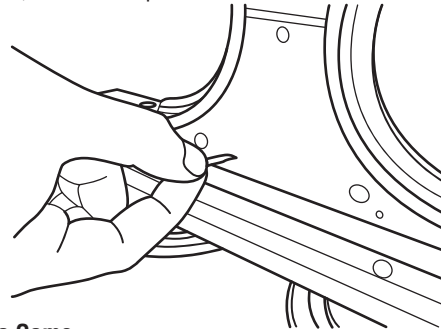

Starting a Game

1. Turn on Loopz™ by pressing the POWER button.

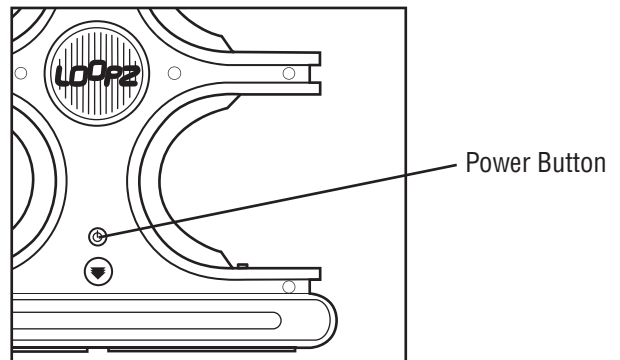

2. When Loopz™ says "Select Game," wave your hand through either of the top two loops to scroll through the list of games. Waving your hand through the top right loop scrolls forward through the list, and the top left loop will scroll backward through the list.
3. To confirm your game choice, wave your hand through either of the bottom loops.
4. Depending on the game you select, you may also be prompted to choose number of players, music tracks or instruments (but we'll cover that in more

detail under each game's description). As before, cycle through your choices using the top two loops and confirm your selection using the bottom two loops.

5. To return to the top of the Game Menu, press the HOME button at any time.
6. To turn off Loopz™, press and hold the POWER button.

TIPS ON "WAVING" YOUR HANDS

Move your hands quickly in and out of the loops. Your hand doesn't need to pass completely through the loop – just far enough to break the sensor beam.

Keep your fingers together. If your fingers are spread, you may accidentally trigger the sensors multiple times and receive an error message.

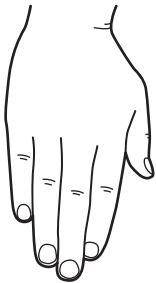

Correct

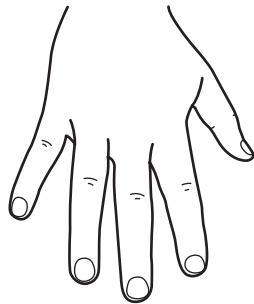

Incorrect

Hold your hands flat, palms downward, to better trigger the sensors. If your hands are sideways when they move through the loops, the sensors will have a harder time reading your movements.

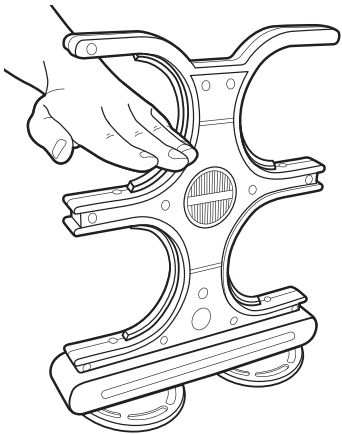

Correct

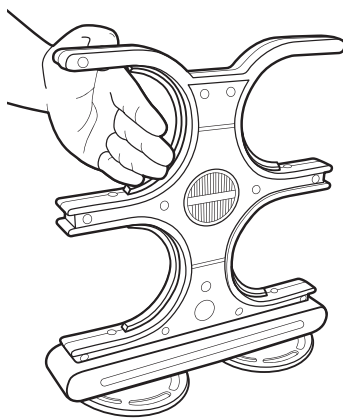

Incorrect

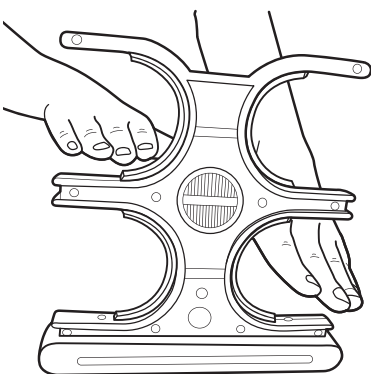

When playing a game, two rings may light up simultaneously. If that happens, move both of your hands through the two rings at the same time.

ADJUSTING THE VOLUME

Loopz™ has 5 volume settings, "5" being the loudest. You can change the volume at any time by *pressing and holding* the HOME button. The unit will cycle through the different volume settings, calling out each one. When you reach the desired setting, release the HOME button.

SCORING

Loopz™ scores your performance differently depending on the game you're playing. Sometimes you score points, but other times you are awarded "medals."

MEDALS

SILVER	GOLD	PLATINUM
1	1	1
2	2	2
3	3	3
4	4	4
5	5	5

Silver-1 is the lowest medal score you can receive, Platinum-5 is the highest.

THE GAMES

Loopz™ features 7 game modes that challenge your memory, your reflexes and your creativity in different ways.

Canceling a Game: To exit a game you are currently playing, press the HOME button and you will return to the Game Menu.

NOTE: After 2-3 minutes of inactivity, Loopz™ will turn itself off. Just press the POWER button to return to the Game Menu.

REPEAT THE BEAT™

Number of Players: 1

Levels: 3

Object: Repeat an ever-increasing pattern of lights.

One light will flash. Repeat it by waving your hand through the matching loop. If you're correct, Loopz™ will replay the light and add one more to the sequence. Continue repeating the pattern as long as you can. If you make 3 mistakes on a level, the game ends.

When you successfully complete an entire sequence (10 prompts), you automatically advance to the next level. The higher the level, the more complicated the patterns, but each pattern will always be 10 prompts long.

To Win the Game: Complete all 3 levels. No matter how far you get, Loopz™ will award you a medal based on your performance.

RHYTHM AND FLOW™

Number of Players: 1

Levels: 3

Object: Keep a song going by waving your hands through loops whenever they light up.

A song starts playing and different loops light up. Wave your hand through the matching loop before its light goes out. If you can keep up with the lights, the song will continue to play. Every time you make a mistake – either by waving your hand through the wrong loop or by missing a light before it

goes out – the song will start over; if you make 6 mistakes on one song, the game ends.

When you keep a song going for 30 seconds, you automatically advance to the next level and another song. Speed and difficulty increase with each new level.

To Win the Game: Complete 3 songs. No matter how far you get, Loopz™ will award you a medal based on your performance.

VERSUS MODE

Number of Players: 2

Levels: None

Object: Two players take turns building and repeating a sequence until one player makes 3 mistakes.

Loopz™ calls out, “Player One – ready, go!” The first player waves their hand through a loop – any loop they want. Loopz™ will then prompt Player Two to go. Player Two must repeat what Player One did then add one more prompt to the sequence – they just wave their hand through any extra loop.

Each player takes turns to repeat the ever-increasing sequence, always adding one more prompt at the end. If a player makes a mistake, Loopz™ will repeat the pattern so they can try again.

To Win the Game: When one player makes 3 mistakes they are out and the game ends. Loopz™ will announce the winner and declare how many correct “hits” the winning player scored.

NOTE: To make things more challenging, you can add double-hand prompts to the sequence – just move your hands through two loops at the same time.

REFLEX MASTER™

Number of Players: 1-4

Levels: 3 (for a one-player game)

1 (for a multi-player game)

Object: “Tag” as many lights as you can before time runs out! Beat your best score or compete against other players – whoever scores the most lights wins!

Wave your hands through the upper loops to cycle through the number of players. When you hear the number you want, confirm your selection by waving your hand through either lower loop.

NOTE: If you don’t confirm the number of players you want, the game will auto-select the last number of players it called out. If it has not called out any players yet, it will default to a one-player game.

• One-Player Game (3 Levels)

Different loops will begin to flash. Move your hands through those loops before the lights go out to score a “hit.” It doesn’t matter how many mistakes you make, Loopz™ only tracks your successful hits. Each level ends after 30 seconds. You must score a minimum number of hits on a level to advance to the next level:

Level 1 – 30 hits

Level 2 – 40 hits

Level 3 – 50 hits

When the game ends, Loopz™ will announce the total number of hits you scored on all levels played.

To Win the Game: Score at least 50 hits on Level 3.

• Multi-Player Game (1 Level)

In a 2-4-player game, there is only 1 level, meaning that each player only goes once. Loopz™ will direct each player to begin and give them 30 seconds to score as many lights as they can. After everyone has had a turn, Loopz™ will call out each player’s score and declare a winner.

To Win the Game: Earn the highest score.

MUSICOLOGY™

Number of Players: 1

Levels: 3

Object: Build songs, one instrument at a time, by repeating random sequences of lights.

Loopz™ will play a random pattern of lights accompanied by the sound of an instrument, such as drums or a bass line. If you successfully repeat the pattern, you will hear part of a song using only that instrument. Loopz™ will proceed to play 4 more patterns, each more challenging than the one before, each featuring a *different* instrument. If you make 3 mistakes during any one pattern, the game ends.

Every time you complete a pattern, Loopz™ will play a music sequence using all the instruments you’ve unlocked up to that point. When you successfully finish 5 patterns, you will have built a complete song (5 instruments) and Loopz™ will play the whole thing for you.

To Win the Game: Complete 3 songs.

FREESTYLE DJ™

Number of Players: 1

Object: Remix the music in Loopz™ by turning tracks on and off.

From the Game Menu, select the song you want to mix, using the upper two loops to cycle through 11 different choices. When you hear the song you want, wave your hand through either lower loop to select it.

NOTE: After 5 seconds with no input, Loopz™ will auto-select the current song.

The selected song will continue playing. Wave your hands through any of the four loops to turn the different tracks off and on.

• Choosing a Different Song

After choosing a song, if you decide you want something different, quickly press the HOME button twice then make a different choice.

• Special Effects

Add a little spice to your mix with some double-hand prompts – wave your hands through two loops at the same time to produce cool effects, such as scratches or “yeahs!” Experiment with different combos of double-hand prompts to see what other effects you can discover.

MUSIC STUDIO

Number of Players: 1

Object: Play Loopz™ like a musical instrument.

From the Game Menu, use the top two loops to cycle through the different instruments you can play. When you hear the sound you want, wave your hand through either of the lower loops to select it. If you decide you want to choose a different instrument after you start playing, quickly press the HOME button twice then make a different choice.

You can play a scale of 10 notes. To play the notes from lowest to highest, just move your hands through the loops as indicated:

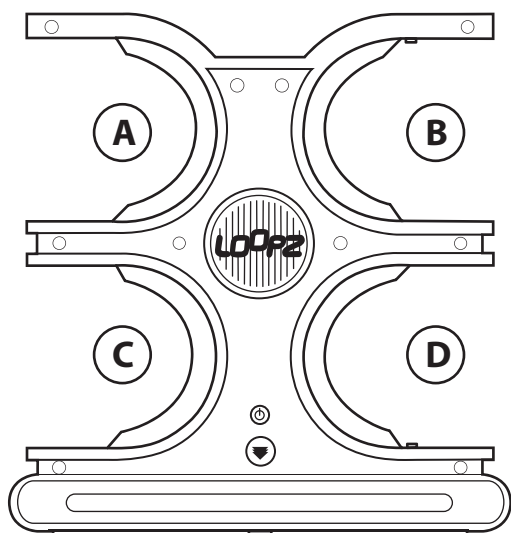

1. A
2. B
3. C
4. D
5. A + B
6. A + C
7. A + D
8. B + C
9. B + D
10. C + D

Visit PlayLoopz.com for more information.

TROUBLESHOOTING

If the unit fails to detect your hand movements...

Refer to "Tips on Waving Your Hands" to make sure you are holding your hands correctly in order to break the sensor beams with maximum efficiency. If this doesn't help, move Loopz™ into an area with less light – too much ambient light (such as bright florescent lights or the sun) can interfere with the sensors.

If the unit locks up...

Use a pin or a paperclip to press the RESET button located on the back of the unit.

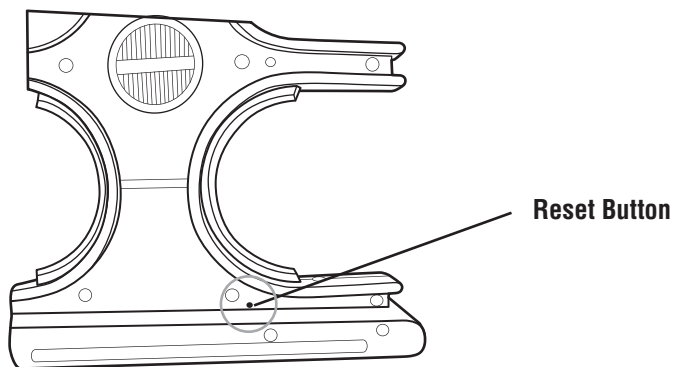

Reset Button

If the lights dim or the sounds become distorted...

Replace the batteries as described above.

For product sold in USA

This device complies with Part 15 of the FCC Rules.

Operation is subject to the following two conditions:

(1) This device may not cause harmful interference, and (2) this device must accept any interference received, including interference that may cause undesired operation.

• This equipment has been tested and found to comply with the limits for a Class B digital device, pursuant to part 15 of the FCC rules. These limits are designed to provide reasonable protection against harmful interference in a residential installation. This equipment generates, uses and can radiate radio frequency energy and, if not installed and used in accordance with the instructions, may cause harmful interference to radio communications. However, there is no guarantee that interference will not occur in a particular installation. If this equipment does cause harmful interference to radio or television reception, which can be determined by turning the equipment off and on, the user is encouraged to try to correct the interference by one or

more of the following measures:

- Reorient or relocate the receiving antenna.
- Increase the separation between the equipment and receiver.
- Connect the equipment into an outlet on a circuit different from that to which the receiver is connected.
- Consult the dealer or an experienced radio/TV technician for help.

NOTE: Changes or modifications not expressly approved by the manufacturer responsible for compliance could void the user's authority to operate the equipment.

For product sold in Canada • Pour les produits vendus au Canada THIS CLASS B DIGITAL APPARATUS COMPLIES WITH CANADIAN ICES-003.

CET APPAREIL NUMÉRIQUE DE LA CLASSE B EST CONFORME À LA NORME NMB-003 DU CANADA.

(VALID FOR CANADA ONLY • VALABLE AU CANADA SEULEMENT)

Operation is subject to the following two conditions :

(1) this device may not cause interference, and (2) this device must accept any interference, including interference that may cause undesired operation of the device.

L'utilisation de ce dispositif est autorisée seulement aux conditions suivantes :

(1) Il ne doit pas produire de brouillage et (2) il doit pouvoir tolérer tout brouillage radioélectrique reçu, même si ce brouillage est susceptible de compromettre son fonctionnement.

BATTERY SAFETY INFORMATION

In exceptional circumstances batteries may leak fluids that can cause a chemical burn injury or ruin your product. To avoid battery leakage:

- Non-rechargeable batteries are not to be recharged.
- Rechargeable batteries are to be removed from the product before being charged (if designed to be removable).
- Rechargeable batteries are only to be charged under adult supervision (if designed to be removable).
- Do not mix alkaline, standard (carbon-zinc), or rechargeable (nickel-cadmium) batteries.
- Do not mix old and new batteries.
- Only batteries of the same or equivalent type as recommended are to be used.
- Batteries are to be inserted with the correct polarity.
- Exhausted batteries are to be removed from the product.
- The supply terminals are not to be short-circuited.
- Dispose of battery(ies) safely.
- Do not dispose of this product in a fire. The batteries inside may explode or leak.



Protect the environment by not disposing of this product with household waste (2002/96/EC). Check your local authority for recycling advice and facilities.



service.mattel.com



T5118-0820

© 2010 Mattel, Inc. All Rights Reserved. Mattel, Inc., 636 Girard Avenue, East Aurora, NY 14052 U.S.A. Consumer Relations 1(800) 524-8697. Mattel Canada Inc., Mississauga, Ontario L5R 3W2. You may call us free at/ Composez sans frais le 1-800-524-8697.