

# GREEN LANTERN

## HAL JORDAN'S RING BLAST™ JET



### SHOOTING PROJECTILES

#### 1. Load projectiles.

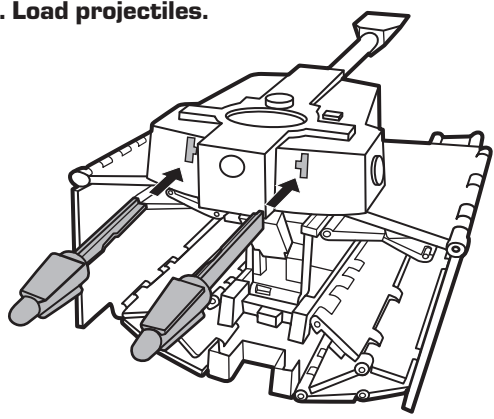

Projectile can jam if not installed straight.

#### 2. Press to launch projectiles.

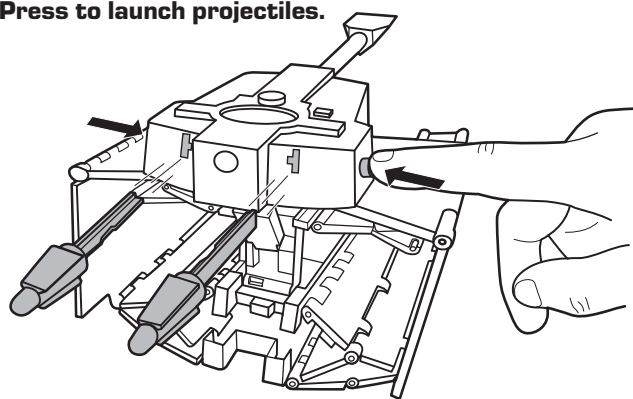

Do not aim at eyes or face. Only use projectiles supplied with this toy. Do not fire at point blank range.

### BATTERY REPLACEMENT

Batteries included are for demonstration purpose only. Replace batteries when sound becomes distorted or lights become dim. Remove batteries included for demonstration purposes and dispose of them safely. To replace batteries, use a Phillips head screwdriver (not included) to open the battery cover. Remove and set aside. Install 3 new button cell (AG13, LR44) batteries as shown. Replace battery cover and tighten screw. For longer life use alkaline batteries. When exposed to an electrostatic source, the product may malfunction. To resume normal operation, remove and re-install the batteries.

### BATTERY SAFETY INFORMATION

In exceptional circumstances batteries may leak fluids that can cause a chemical burn injury or ruin your product. To avoid battery leakage:

- Non-rechargeable batteries are not to be recharged.
- Rechargeable batteries are to be removed from the product before being charged.
- Rechargeable batteries are only to be charged under adult supervision.
- Do not mix alkaline, standard (carbon-zinc), or rechargeable (nickel-cadmium) batteries.
- Do not mix old and new batteries.
- Only batteries of the same or equivalent type as recommended are to be used.
- Batteries are to be inserted with the correct polarity.
- Exhausted batteries are to be removed from the product.
- The supply terminals are not to be short-circuited.
- Dispose of battery(ies) safely.
- Do not dispose of this product in a fire. The batteries inside may explode or leak.

Protect the environment by not disposing of this product with household waste (2002/96/EC). Check your local authority for recycling advice and facilities.

### This device complies with Part 15 of the FCC Rules.

Operation is subject to the following two conditions: (1) This device may not cause harmful interference, and (2) this device must accept any interference received, including interference that may cause undesired operation.

This equipment has been tested and found to comply with the limits for a Class B digital device, pursuant to part 15 of the FCC rules. These limits are designed to provide reasonable protection against harmful interference in a residential installation. This equipment generates, uses and can radiate radio frequency energy and, if not installed and used in accordance with the instructions, may cause harmful interference to radio communications. However, there is no guarantee that interference will not occur in a particular installation. If this equipment does cause harmful interference to radio or television reception, which can be determined by turning the equipment off and on, the user is encouraged to try to correct the interference by one or more of the following measures:

- Reorient or relocate the receiving antenna.
- Increase the separation between the equipment and receiver.
- Connect the equipment into an outlet on a circuit different from that to which the receiver is connected.
- Consult the dealer or an experienced radio/TV technician for help.

**NOTE:** Changes or modifications not expressly approved by the manufacturer responsible for compliance could void the user's authority to operate the equipment.

© 2011 Mattel, Inc. All Rights Reserved. Mattel, Inc., 636 Girard Avenue, East Aurora, NY 14052, U.S.A. Consumer Relations 1-800-524-8697. Mattel U.K. Ltd., Vanwall Business Park, Maidenhead SL6 4UB. Helpline 01628 500303. Mattel Australia Pty. Ltd., Richmond, Victoria 3121 Consumer Advisory Service - 1300 135 312. Mattel East Asia Ltd., Room 1106, South Tower, World Finance Centre, Harbour City, Tsimshatsui, HK, China. Dilmport & Diedarkan Oleh: Mattel SEA Ptd 19178-0920 Ltd. (993532-P) Lot 13.5, 13th Floor, Menara Lien Hoe, Persiaran Tropiana Golf Country Resort, 47410 PJ. Tel: 03-78803817, Fax: 03-78803867.

Based on DC Comics Characters. GREEN LANTERN and all related characters and elements are trademarks of & © DC Comics. SERVICE.MATTEL.COM



### INSTRUCTIONS

Please keep these instructions for future reference as they contain important information.

### CONTENTS

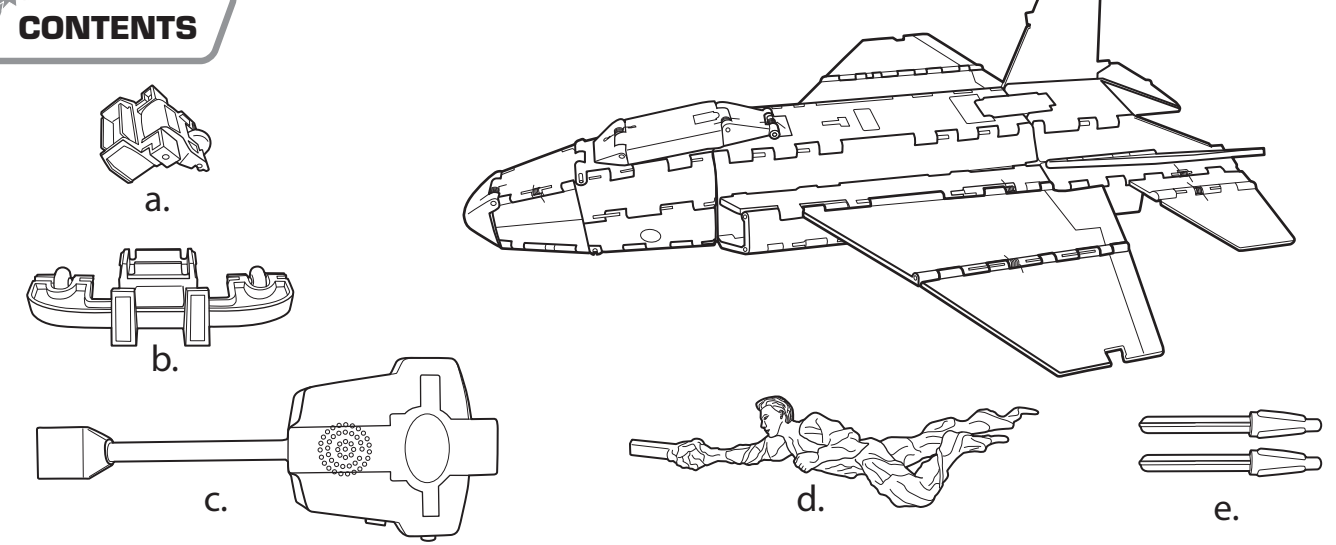

### ASSEMBLY

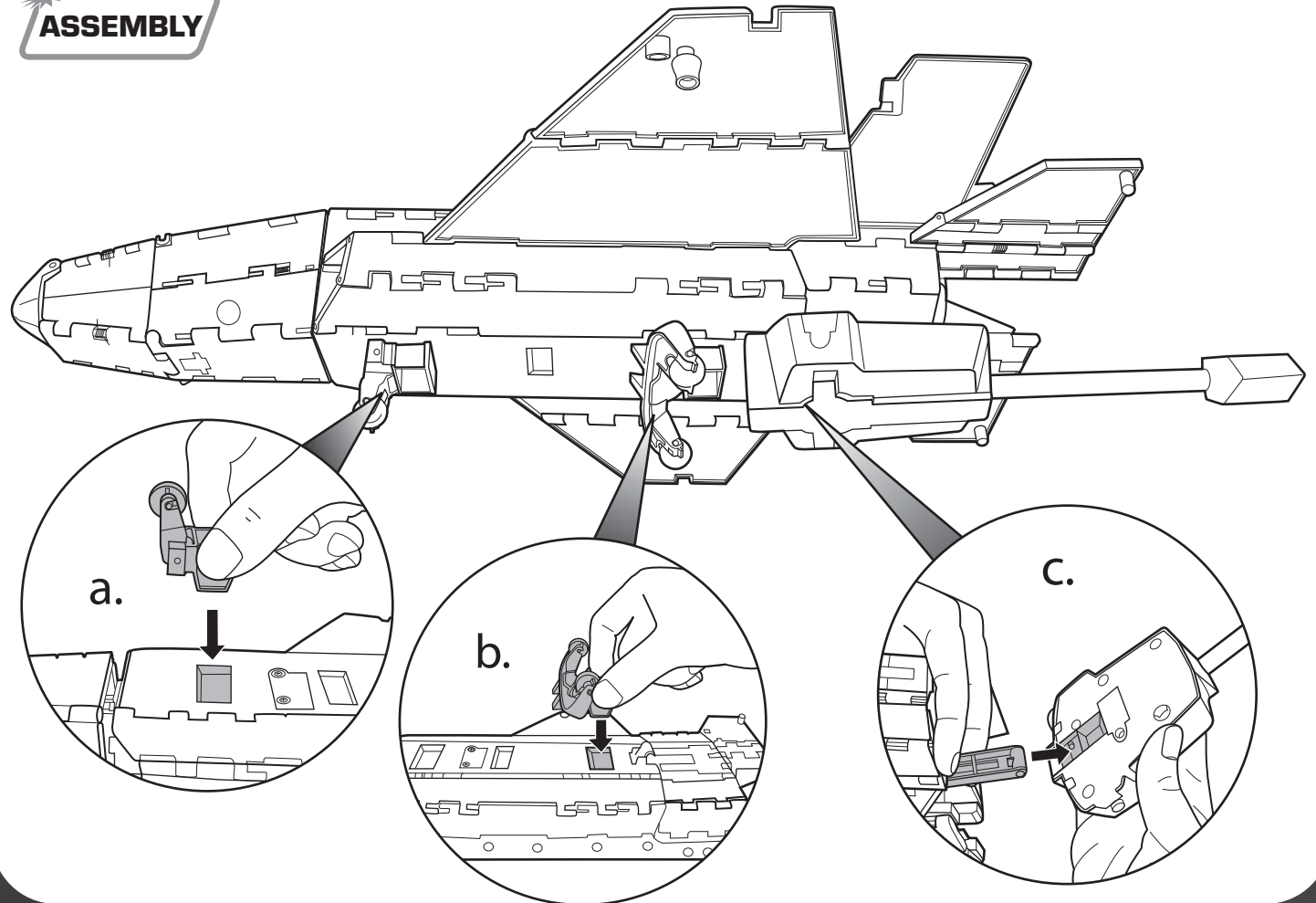

### TRANSFORM INTO TANK

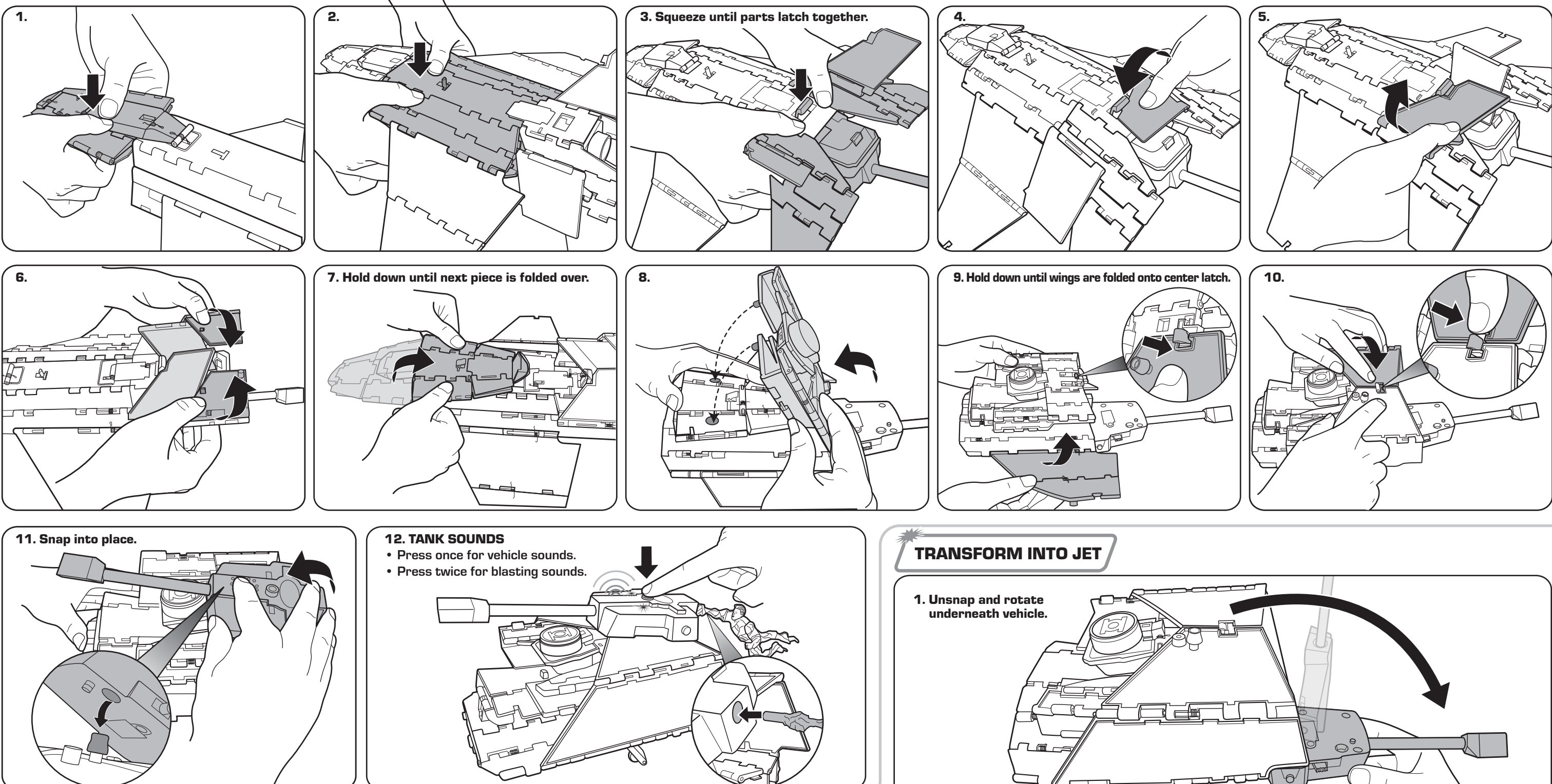

### TRANSFORM INTO JET

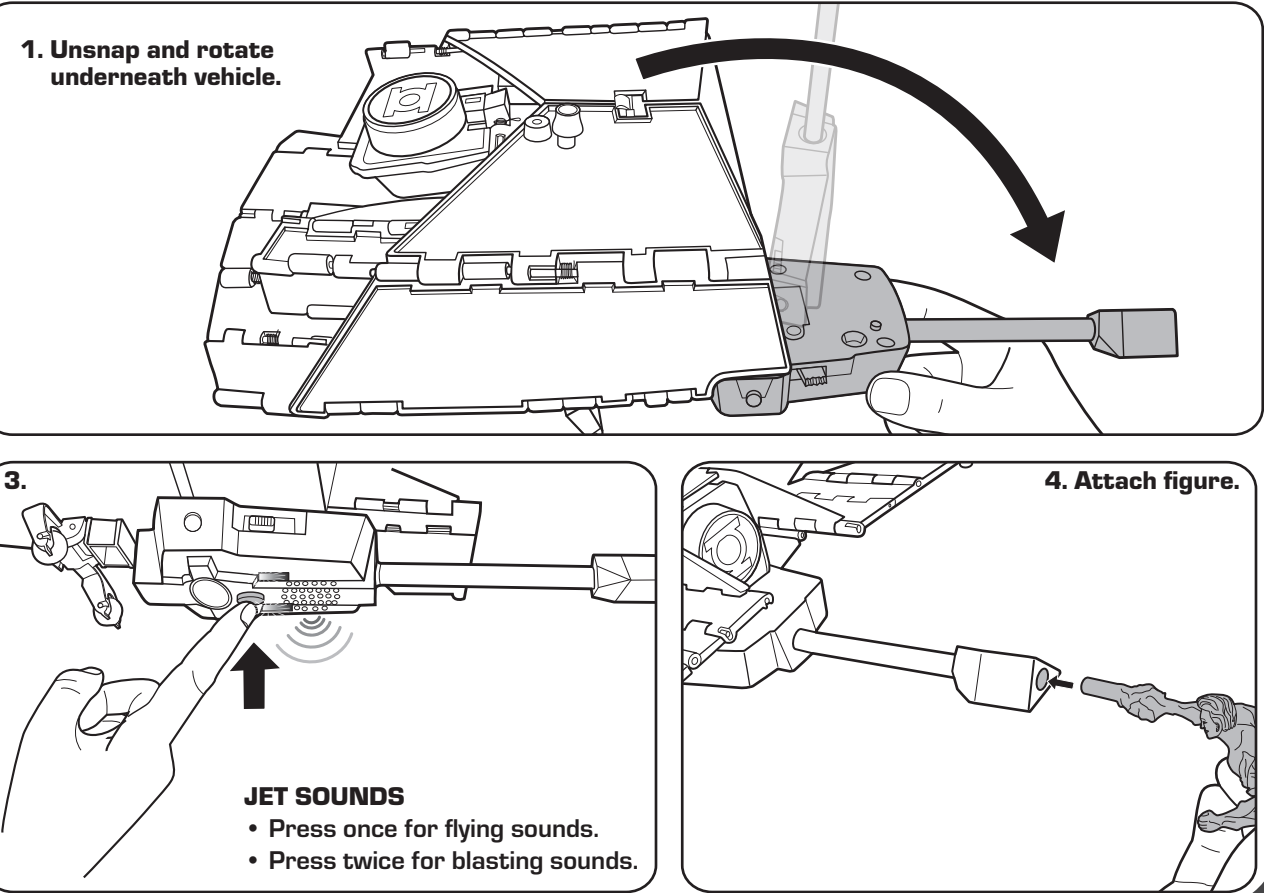

2. Press disk down completely and release for INSTANT TRANSFORMATION!

**JET SOUNDS**  
 • Press once for flying sounds.  
 • Press twice for blasting sounds.