

Fisher-Price®

V4599



Fits child's shoe size	US	UK
	6-12	5-11

Please save this instruction sheet for future reference, as it contains important information.

Adult supervision is required.

Wheel and size adjustments should be done by an adult.

For ages 2 years and up.

The skates are designed to be worn on either foot.

Protective equipment shown in this photo is not included with this toy.

[www.fisher-price.com](http://www.fisher-price.com)

## Safety Information



### WARNING

Protective equipment should be worn. Use helmet, wrist guards, knee pads and elbow pads (all not included). Not for children with a body weight of more than 44 lbs. (20 kg).

**IMPORTANT!** Please take a moment to review the following safety tips with your skater.

- Always wear a helmet, knee pads, wrist guards and elbow pads to guard against bumps and bruises (all not included).
- Wear shoes or sneakers, not open-toe shoes.
- Keep loose pant legs away from the wheels.
- Beginner skaters should be supervised. Hold the beginner's hand and guide the new skater along a smooth, level surface.
- Learn how to brake and stop safely in these skates.
- Choose areas for skating which are free of obstacles.
- Never skate in areas with water, wet spots, snow, ice, sand, oil, gravel etc.
- Never skate on streets, roadways and driveways which enter vehicle traffic routes.
- Towing skaters with bicycles or cars is unsafe.
- Never skate at night.
- Do not skate down hills. Braking is gradual with these skates. Keep this in mind to allow enough stopping distance.
- Please use with caution, as this product requires skill to operate safely. Avoid falls, collisions, and injuries to yourself and others.
- Before skating, check to be sure all wheels, the brake, straps and other plastic parts are not loose, cracked, broken or worn out. Tighten all parts as necessary. If any parts are cracked, broken or worn out, discard the skates.

## Wheel Control Adjustment

Wheel Control Plate

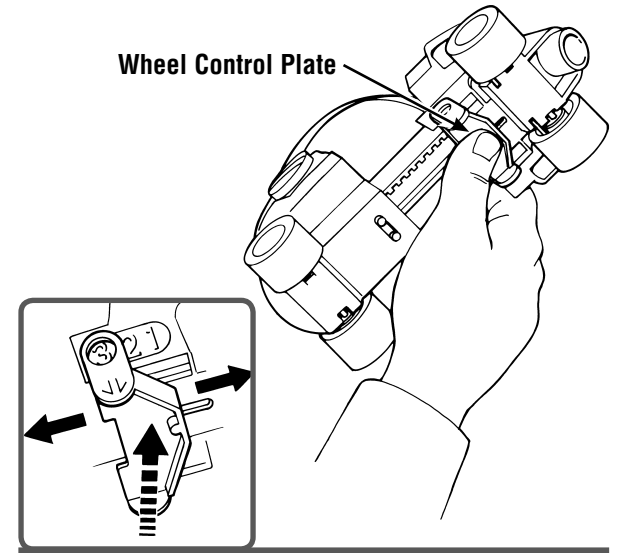

- Locate the wheel control plate on the bottom of the skate.
- **Press down** and slide the wheel control plate to:
  - 1 FULL STOP (WALK)**  
The front wheel locks so your skater can walk on the skates to get used to them.
  - 2 FORWARD ONLY**  
Your skater can roll forward but the front wheels lock to prevent rolling backward.
  - 3 FREE WHEELING**  
Your skater rolls forward and backward unrestricted.
- Make sure both skates are set to the same wheel control position.
- The wheel control function works only when your child is wearing and putting weight on the skate.

# Consumer Information

## Care

- Periodically lubricate the rear axle on each skate with a little petroleum jelly.
- Check plastic parts on a regular basis and discard if broken or cracked.

## Helmet Information

Your child must always wear a bicycle helmet when using this product. Helmets reduce the energy of some impacts, minimizing or preventing head injuries. Make sure your child's helmet has a label stating/certifying conformance with the applicable certifying agency and includes the intended age requirement for use with a child. In addition, children ages 1 to 5 years require helmets specifically designed and labeled for younger children. These helmets cover a larger portion of the head and provide more protective coverage than other helmets for older persons.

For maximum protection during an impact, the helmet must be properly secured to your child's head. The helmet must have a strap that goes under the chin with a buckle that stays securely fastened. The helmet should be worn level/low on the forehead, not tilted back. The chinstrap should be adjusted so there is no slack and it is firmly buckled (see helmet instructions). After securing the helmet to your child's head, test to be sure that the strap stays tight, the buckle remains secure and the helmet cannot be removed from your child's head by twisting or pulling the helmet. Remind your child to remove the helmet when playing on any kind of playground equipment or any place where the helmet may present a risk of strangulation.

If the helmet is involved in a crash, replace it or have it examined by the manufacturer before reuse.

# Fitting the 1-2-3 Roller Skates

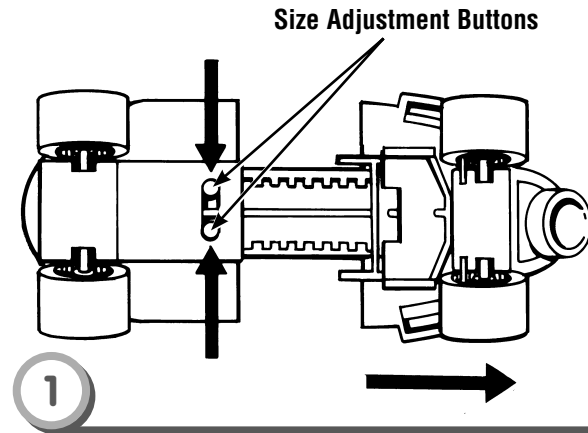

- 1
- Turn the skate upside down.
  - Squeeze the size adjustment buttons together, while pulling the front of the skate to the fully extended position.
  - Repeat this procedure to open the other skate to the fully extended position.

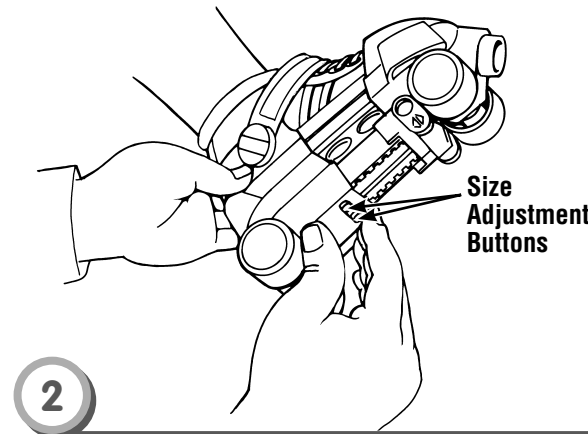

- 2
- Make sure your child is seated.
  - Place your child's foot in the skate.
  - Squeeze the size adjustment buttons together, while pushing the front of the skate to the appropriate size for your child.
  - Repeat this procedure to adjust the size of the other skate to your child's other foot.

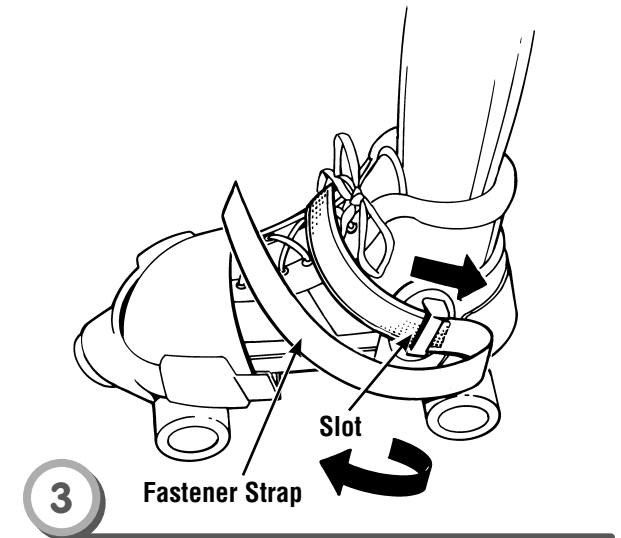

- 3
- Insert the skate fastener strap into the slot on the side of the skate.
  - Pull the fastener strap tight and fold it back on itself to secure.

## CONSUMER ASSISTANCE

1-800-432-5437 (US & Canada)  
1300 135 312 (Australia)

[service.fisher-price.com](http://service.fisher-price.com)

Fisher-Price, Inc., 636 Girard Avenue, East Aurora, NY 14052.  
Hearing-impaired consumers: 1-800-382-7470.

Outside the United States:

Canada: Mattel Canada Inc., 6155 Freemont Blvd.,  
Mississauga, Ontario L5R 3W2; [www.service.mattel.com](http://www.service.mattel.com).

Great Britain: Mattel UK Ltd, Vanwall Business Park,  
Maidenhead SL6 4UB. Helpline: 01628 500303.  
[www.service.mattel.com/uk](http://www.service.mattel.com/uk)

Mattel Europa, B.V., Gondel 1, 1186 MJ Amstelveen, Nederland.

Australia: Mattel Australia Pty. Ltd., 658 Church Street,  
Locked Bag #870, Richmond, Victoria 3121 Australia.

New Zealand: 16-18 William Pickering Drive,  
Albany 1331, Auckland.