

### BATTERY INSTALLATION

Unscrew and lift cover away from top of Percy.  
Install battery as indicated inside the battery compartment.  
For longer life use only alkaline batteries.  
Requires 1 "AA" (LR6) battery.  
If this toy begins to operate erratically, you may need to reset the electronics.  
Remove the batteries from the toy and replace it.

### BATTERY SAFETY INFORMATION

In exceptional circumstances batteries may leak fluids that can cause a chemical burn injury or ruin your toy (product). To avoid battery leakage:

- Non-rechargeable batteries are not to be recharged.
- Rechargeable batteries are to be removed from the product before being charged (if designed to be removable).
- Rechargeable batteries are only to be charged under adult supervision (if designed to be removable).
- Do not mix alkaline, standard (carbon-zinc), or rechargeable (nickel-cadmium) batteries.
- Do not mix old and new batteries.
- Only batteries of the same or equivalent type as recommended are to be used.
- Batteries are to be inserted with the correct polarity.
- Exhausted batteries are to be removed from the product.
- The supply terminals are not to be short-circuited.
- Dispose of battery(ies) safely.
- Do not dispose of this product in a fire. The batteries inside may explode or leak.

This equipment has been tested and found to comply with the limits for a Class B digital device, pursuant to part 15 of the FCC rules. These limits are designed to provide reasonable protection against harmful interference in a residential installation. This equipment generates, uses and can radiate radio frequency energy and, if not installed and used in accordance with the instructions, may cause harmful interference to radio communications. However, there is no guarantee that interference will not occur in a particular installation. If this equipment does cause harmful interference to radio or television reception, which can be determined by turning the equipment off and on, the user is encouraged to try to correct the interference by one or more of the following measures:

Reorient or relocate the receiving antenna. Increase the separation between the equipment and receiver. Connect the equipment into an outlet on a circuit different from that to which the receiver is connected. Consult the dealer or an experienced radio/TV technician for help.

NOTE: Changes or modifications not expressly approved by the manufacturer responsible for compliance could void the user's authority to operate the equipment.

This device complies with part 15 of the FCC Rules. Operation is subject to the following two conditions:

(1) This device may not cause harmful interference, and

(2) this device must accept any interference received, including interference that may cause undesired operation.

• THIS CLASS B DIGITAL APPARATUS COMPLIES WITH CANADIAN ICES-003.

• CET APPAREIL NUMERIQUE DE LA CLASSE B EST CONFORME A LA NORME NMB-003 DU CANADA.

• Operation is subject to the following two conditions: (1) this device may not cause interference, and (2) this device must accept any interference, including interference that may cause undesired operation of the device.

• L'utilisation de ce produit est sujette aux conditions suivantes : (1) il ne doit pas produire de brouillage et

(2) il doit pouvoir tolérer tout brouillage reçu, même si ce brouillage est susceptible de compromettre son fonctionnement.

### Percy

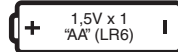

Required tool:  
Phillips screwdriver  
(not included)

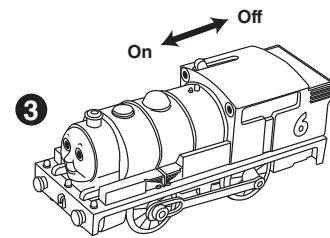
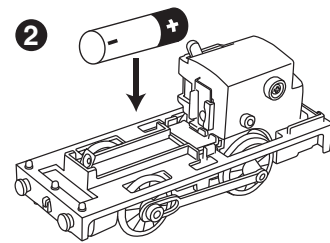
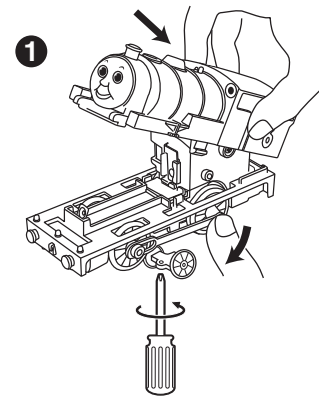

Protect the environment by not disposing of this product with household waste (2002/96/EC). Check your local authority for recycling advice and facilities.

Thomas the Tank Engine & Friends™



CREATED BY BRIT ALLCROFT

Based on the Railway Series by The Reverend W Awdry.

© 2011 Gullane (Thomas) Limited.

Thomas the Tank Engine & Friends and Thomas & Friends

are trademarks of Gullane (Thomas) Limited.

© HIT Entertainment Limited.

HIT and the HIT logo are trademarks of HIT Entertainment Limited.

Fisher-Price, Inc., a subsidiary of Mattel, Inc.,

East Aurora, NY 14052 U.S.A.

PRINTED IN CHINA.

Manufactured for Fisher-Price.

©2011 Mattel, Inc. All Rights Reserved.

® and ™ designate U.S. trademarks of Mattel, Inc.,

unless otherwise indicated.

Mattel East Asia Ltd., Room 1106, South Tower, World Finance Centre,

Harbour City, Tsimshatsui, HK, China.

**CAUTION:**  
To prevent entanglement,  
keep hair away from wheels.



**Fisher-Price**

V8903

ID: V8903-0920G1



## RAISE & LOWER DRAWBRIDGE

### INSTRUCTIONS

Please keep these instructions for future reference as they contain important information.



### Assembly

1. Assemble the bridge by attaching the sides of the bridge to the base. Attach the track pieces to the water piece and then attach the drawbridge to the track pieces as shown.

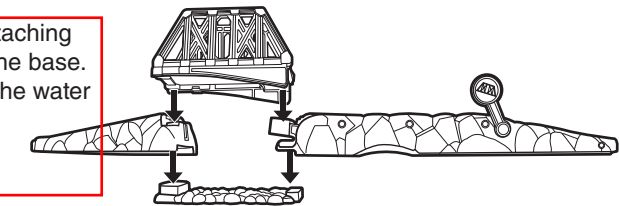

2. Attach the drawbridge to any existing Trackmaster track layout (sold separately).

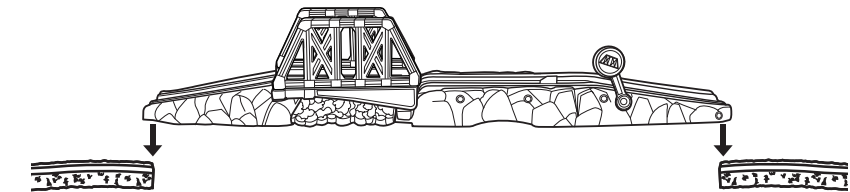

### How To Play

1. Set the brake lever to the STOP position. As the engine approaches, the brake switch will stop the engine in front of the drawbridge. While the engine is stopped in front of the drawbridge, the wheels of the engine will power the drawbridge to rise.

While the engine is stopped in front of the drawbridge, the wheels of the engine will power the drawbridge to rise.

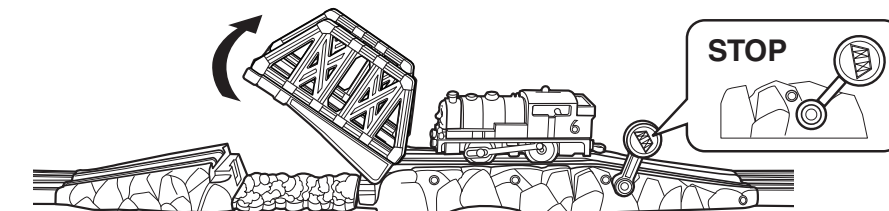

2. Set the brake lever to the GO position to lower the drawbridge and send the engine on its way over the bridge.



NOTE: Do not touch the moving drawbridge while the engine is powering it.

**ADULT ASSEMBLY REQUIRED.** No tools required for assembly.

**CONSUMER ASSISTANCE**  
1-800-432-5437 (US & Canada)  
1300 135 312 (Australia)  
**service.fisher-price.com**

Fisher-Price, Inc., 636 Girard Avenue, East Aurora, NY 14052.  
Hearing-impaired consumers: 1-800-382-7470.

Outside the United States:

Canada: Mattel Canada Inc., 6155 Freemont Blvd.,  
Mississauga, Ontario L5R 3W2; www.service.mattel.com.

Great Britain: Mattel UK Ltd, Vanwall Business Park,  
Maidenhead SL6 4UB. Helpline: 01628 500303.  
www.service.mattel.com/uk

Mattel Europa, B.V., Gondel 1, 1186 MJ Amstelveen, Nederland.

Australia: Mattel Australia Pty. Ltd., 658 Church Street,  
Locked Bag #870, Richmond, Victoria 3121 Australia.

New Zealand: 16-18 William Pickering Drive,  
Albany 1331, Auckland.

Item No : V8903-0920G1  
Version : EL  
Size : 16.54" x 11.69" (A3)  
Paper : Woodfree paper 80 gsm  
Color : Black  
Date : April 6, 2011 (WC)

04/06/11 Remark for G1  
- Revised copies