

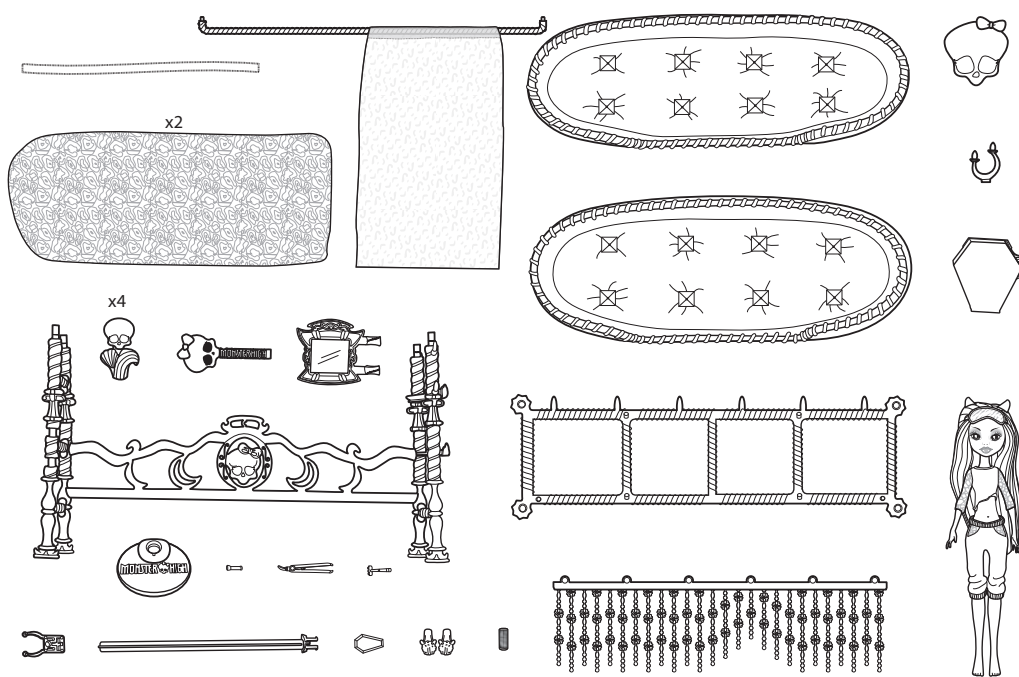

### INSTRUCTIONS

#### CONTENTS

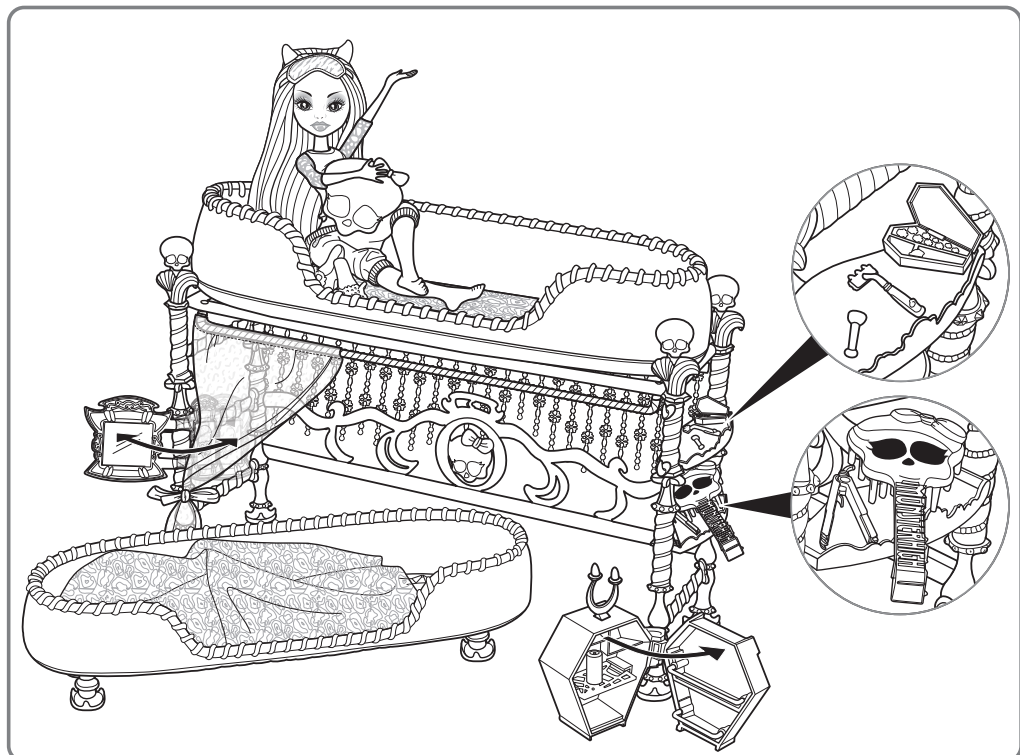

Doll cannot stand alone.

Please remove everything from the package and compare to the contents shown here. If any items are missing, please contact your local Mattel office. Keep these instructions for future reference as they contain important information.



#### INSTRUCTION SHEET SPECIFICATIONS

Toy:	MONSTER HIGH ROOM DECOR
Toy No.:	W2577
Part No.:	0920
Lang. Code:	Dom
Trim Size:	148.5 W x 210 H
Folded Size:	297 W x 210 H
Type of Fold:	2 panel
# colors:	One
Colors:	Black
Paper Stock:	White Offset
Paper Weight:	70 lb.
EDM No.:	00

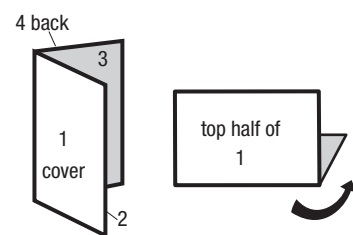
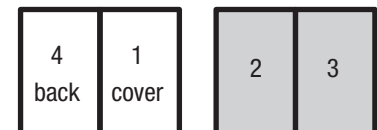

#### CONSUMER INFORMATION

Need Assistance? Visit [service.mattel.com](http://service.mattel.com) or call 1-800-524-8697 (US and Canada only).

[SERVICE.MATTEL.COM](http://SERVICE.MATTEL.COM)

Mattel, Inc., 636 Girard Avenue, East Aurora, NY 14052, U.S.A. Consumer Relations 1-800-524-8697.  
 Mattel U.K. Ltd., Vanwall Business Park, Maidenhead SL6 4UB. Helpline 01628 500303. Mattel Australia Pty., Ltd., Richmond, Victoria. 3121. Consumer Advisory Service - 1300 135 312. Mattel East Asia Ltd., Room 1106, South Tower, World Finance Centre, Harbour City, Tsimshatsui, HK, China.  
 Diimport & Diedarkan Oleh: Mattel SEA Ptd Ltd. (993532-P) Lot 13.5, 13th Floor, Menara Lien Hoe, Persiaran Tropicana Golf Country Resort, 47410 PJ. Tel:03-78803817, Fax:03-78803867.

©2011 Mattel, Inc. All Rights Reserved.

### Assembly

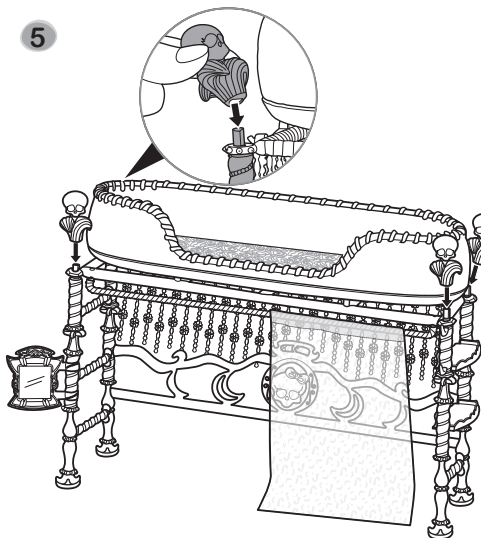
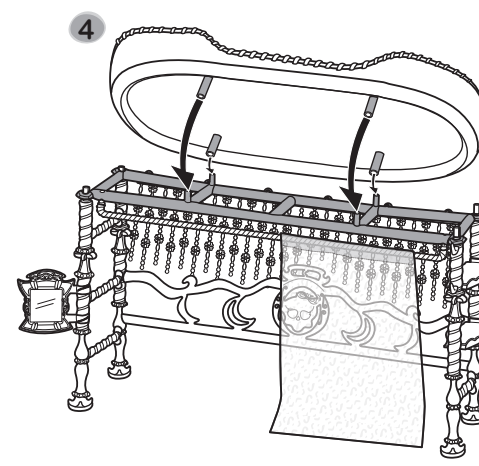
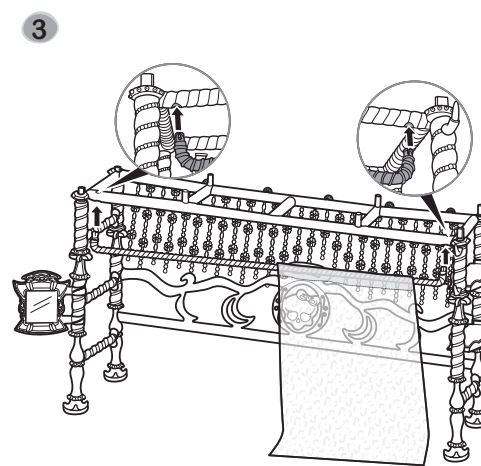
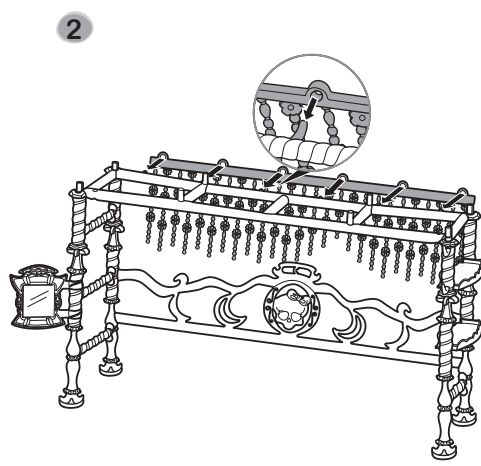
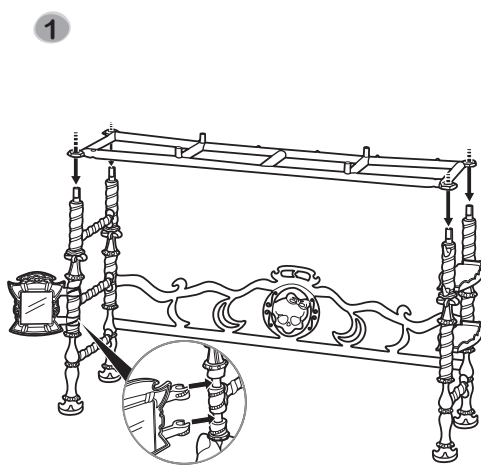

**Helpful tip:** For easy assembly, please ensure four skeleton decorations face forward.

#### Let's Play!

