

**INSTRUCTION SHEET SPECIFICATIONS**

Toy: HOT WHEELS COLOR SHIFTERS HP SET  
 Toy No.: W3413  
 Part No.: 0920  
 Trim Size: 22"W x 8.5" H  
 Fokked Size: 5.5"W x 8.5" H  
 Type of Fold: Single  
 # colors: One  
 Colors: Black  
 Paper Stock: White Offset  
 Paper Weight: 70 lb.  
 EDM No.:

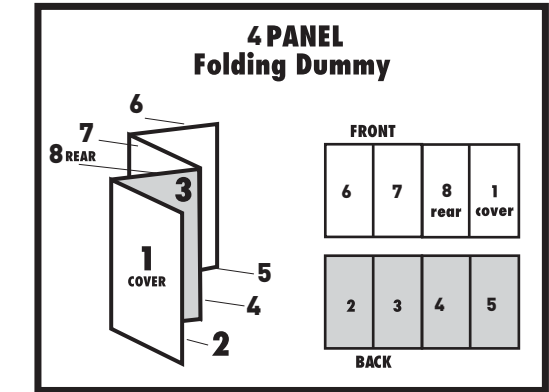

**TO PLAY**

**1. PRESS TO START RACE!**

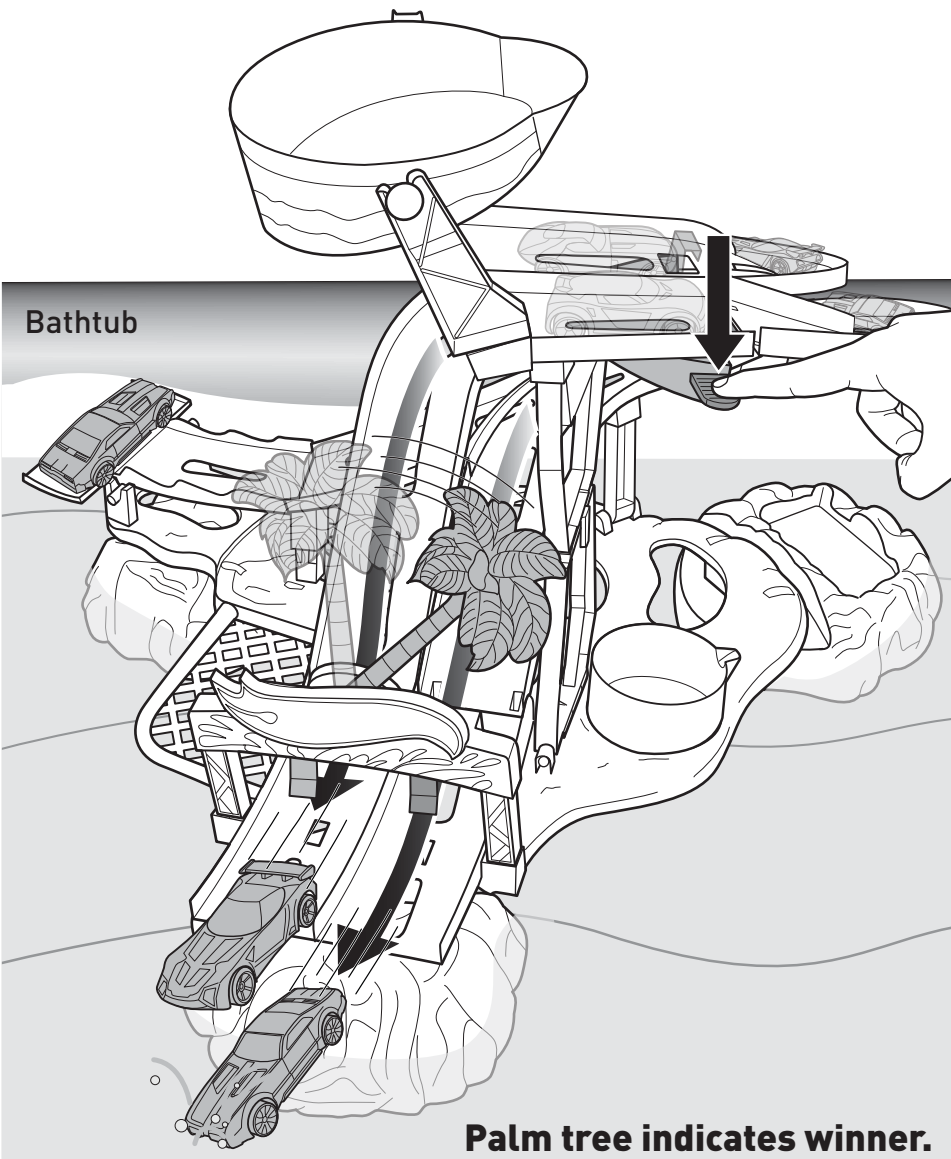

Drain, rinse, clean and dry all items thoroughly before storing.

**2. USE WATER FOR MORE POWER!**

Turn lever to change lane.

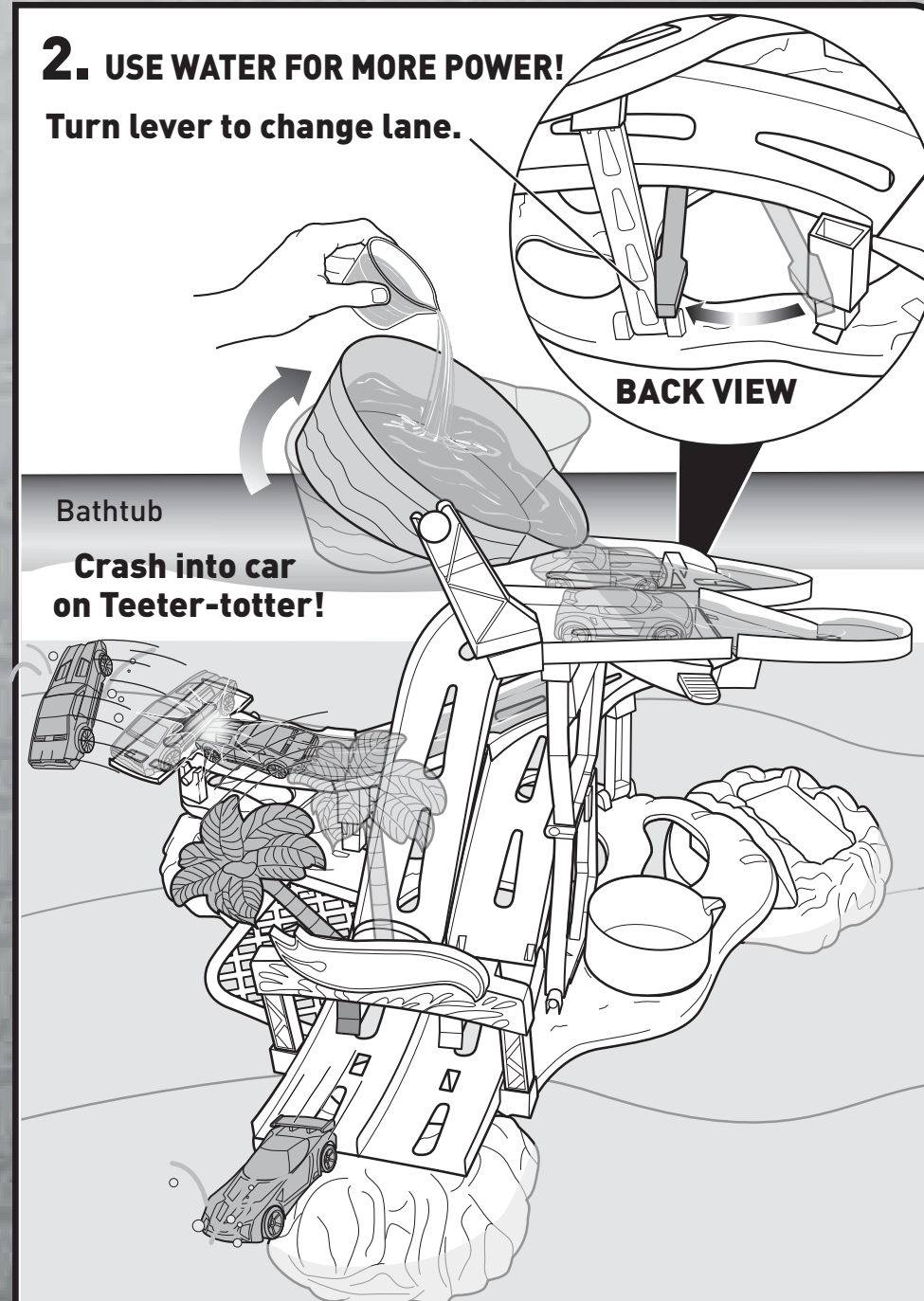

**RACE RALLY WATER PARK™**

**INSTRUCTIONS**

Please keep these instructions for future reference as they contain important information.

**CONTENTS**

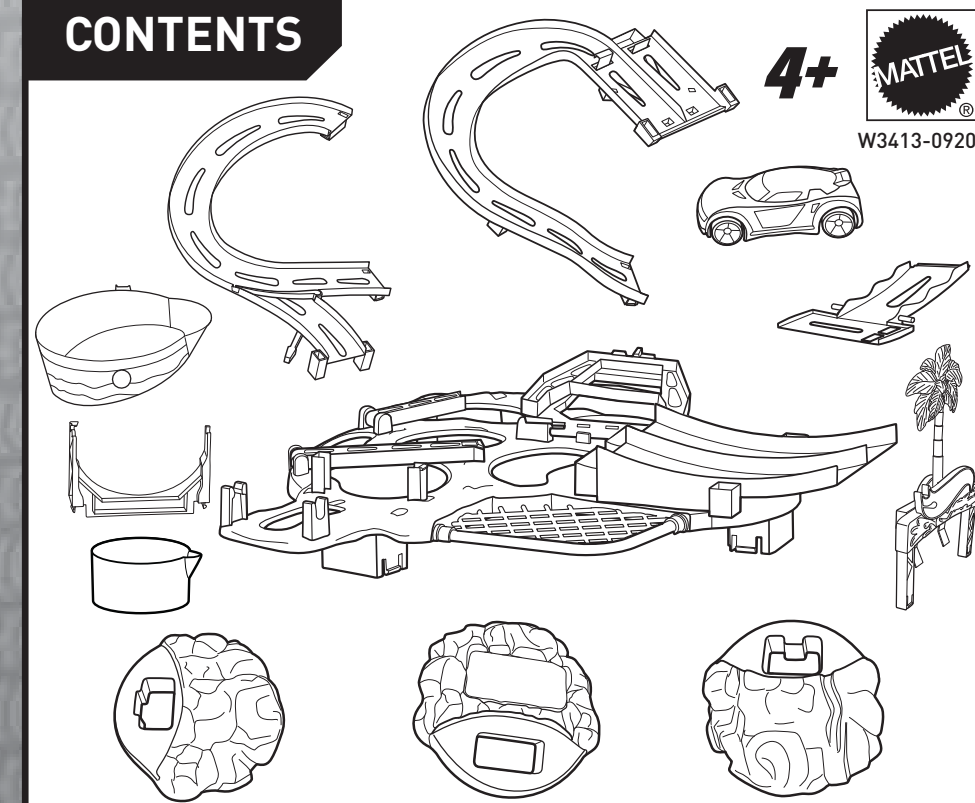

©2011 Mattel, Inc. All Rights Reserved. Mattel, Inc., 636 Girard Avenue, East Aurora, NY 14052, U.S.A. Consumer Relations 1-800-524-8697. • Mattel Canada Inc., Mississauga, Ontario L5R 3W2. You may call us free at 1-800-524-8697. • Mattel U.K. Ltd., Vanwall Business Park, Maidenhead SL6 4UB. Helpline 01628 500303. • Mattel Australia Pty., Ltd., Richmond, Victoria, 3121. Consumer Advisory Service - 1300 135 312. Mattel East Asia Ltd., Room 1106, South Tower, World Finance Centre, Harbour City, Tsimshatsui, HK, China. • Distributor & Diederkeren Oleh: Mattel SEA Ptd Ltd. (993532-P) Lot 13.5, 13th Floor, Menara Lien Hoe, Persiaran Tropicana Golf Country Resort, 47410 PJ. Tel:03-78803817, Fax:03-78803867. service.mattel.com

**ASSEMBLY**

