

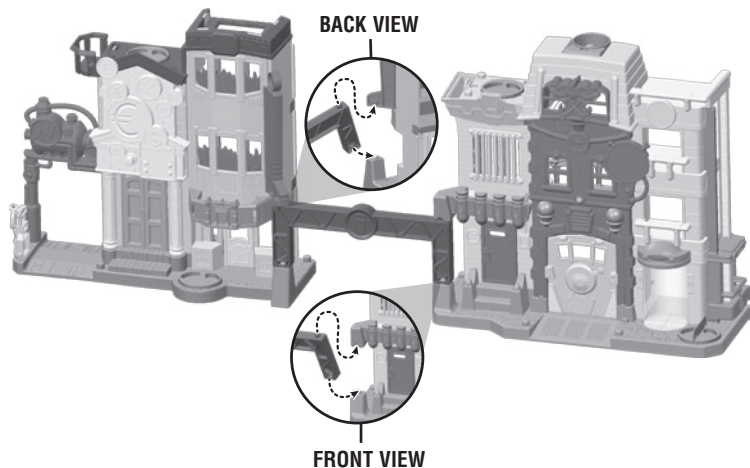

Please keep this instruction sheet for future reference,
as it contains important information.
Requires two AA and two AAA batteries
(batteries included) for operation.
Batteries included are for demonstration purposes only.
Adult assembly is required.
Tool required for battery replacement:
Phillips screwdriver (not included).

Assembly



- At an angle, fit the bottom of one end of the bridge post onto the building support, as shown.
- Push to **“snap”** the top of the same end of the bridge post in place.
- Repeat this procedure to assemble the other end of the bridge to the other building.

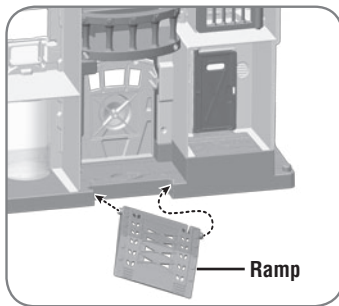
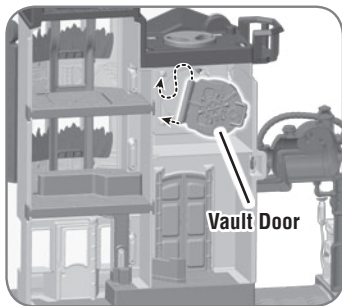

The vault door and ramp are designed to break away from the product. If they fall off, simply follow the steps below to reassemble.

- At an angle, fit the bottom of the vault door into the post on the building. Push to **“snap”** the top of the door in place.
- At an angle, fit one side of the ramp into the groove on the building. Push to **“snap”** the other side of the ramp in place.

Battery Replacement

We recommend the use of **alkaline** batteries for longer battery life.
When sounds/lights become faint or stop, it's time for an adult to change the batteries.

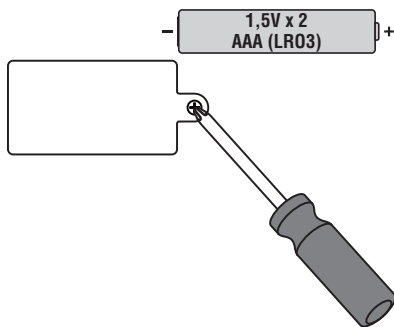
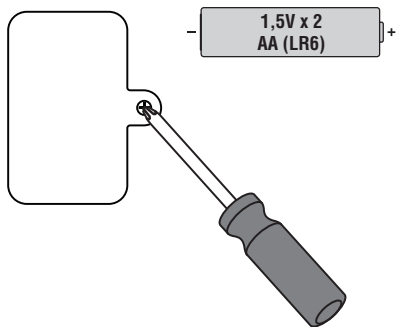

Building

- Locate the battery compartment door on the bottom of the building.
- Loosen the screw in the battery compartment door with a Phillips screwdriver. Remove the door.
- Remove the exhausted batteries and dispose of them properly.
- Insert two, new AA (LR6) **alkaline** batteries.
- Replace the battery compartment door and tighten the screw. Do not over-tighten.
- If the building begins to operate erratically you may need to reset the electronics. Slide the power switch off and back on.

Truck

- Locate the battery compartment door on the bottom of the truck.
- Loosen the screw in the battery compartment door with a Phillips screwdriver and remove the door.
- Remove the exhausted batteries and dispose of them properly.
- Insert two, new AAA (LR03) **alkaline** batteries.
- Replace the battery compartment door and tighten the screw. Do not over-tighten.
- If the building does not respond when you press the button on the truck, may need to reset the electronics. First slide the power switch on the building off and then back on. Then, remove the batteries in the truck and reinstall them.



CONSUMER ASSISTANCE

1-800-432-5437 (US & Canada)

1300 135 312 (Australia)

 service.fisher-price.com

Fisher-Price, Inc., 636 Girard Avenue, East Aurora, NY 14052.

Hearing-impaired consumers: 1-800-382-7470.

Outside the United States:

Canada: Mattel Canada Inc., 6155 Freemont Blvd.,
Mississauga, Ontario L5R 3W2; www.service.mattel.com.

Great Britain: Mattel UK Ltd, Vanwall Business Park,
Maidenhead SL6 4UB. Helpline: 01628 500303.
www.service.mattel.com/uk

Mattel Europa B.V., Gondel 1, 1186 MJ Amstelveen, Nederland.

Australia: Mattel Australia Pty. Ltd., 658 Church Street,
Locked Bag #870, Richmond, Victoria 3121 Australia.

New Zealand: 16-18 William Pickering Drive,
Albany 1331, Auckland.

FCC Statement (United States Only)

This equipment has been tested and found to comply with the limits for a Class B digital device, pursuant to Part 15 of the FCC Rules. These limits are designed to provide reasonable protection against harmful interference in a residential installation. This equipment generates, uses and can radiate radio frequency energy and, if not installed and used in accordance with the instructions, may cause harmful interference to radio communications. However, there is no guarantee that interference will not occur in a particular installation. If this equipment does cause harmful interference to radio or television reception, which can be determined by turning the equipment off and on, the user is encouraged to try to correct the interference by one or more of the following measures:

- Reorient or relocate the receiving antenna.
- Increase the separation between the equipment and receiver.
- Consult the dealer or an experienced radio/TV technician for help.

Note: Changes or modifications not expressly approved by the manufacturer responsible for compliance could void the user's authority to operate the equipment.

This device complies with Part 15 of the FCC Rules. Operation is subject to the following two conditions: (1) this device may not cause harmful interference and (2) this device must accept any interference received, including interference that may cause undesired operation.

Consumer Information

Battery Safety Information

In exceptional circumstances, batteries may leak fluids that can cause a chemical burn injury or ruin your product. To avoid battery leakage:

- Do not mix old and new batteries or batteries of different types: alkaline, standard (carbon-zinc) or rechargeable (nickel-cadmium).
- Insert batteries as indicated inside the battery compartment.
- Remove batteries during long periods of non-use. Always remove exhausted batteries from the product. Dispose of batteries safely. Do not dispose of this product in a fire. The batteries inside may explode or leak.
- Never short-circuit the battery terminals.
- Use only batteries of the same or equivalent type, as recommended.
- Do not charge non-rechargeable batteries.
- Remove rechargeable batteries from the product before charging.
- If removable, rechargeable batteries are used, they are only to be charged under adult supervision.

Care

- Wipe this toy with a clean damp cloth. Do not immerse.
- This toy has no consumer serviceable parts. Do not take apart.



- Protect the environment by not disposing of this product with household waste (2002/96/EC). Check your local authority for recycling advice and facilities.

ICES-003

- This Class B digital apparatus complies with Canadian ICES-003.
- Operation is subject to the following two conditions: (1) this device may not cause harmful interference and (2) this device must accept any interference received, including interference that may cause undesired operation.

NMB-003

- Cet appareil numérique de la classe B est conforme à la norme NMB-003 du Canada.
- L'utilisation de ce dispositif est autorisée seulement aux conditions suivantes : (1) il ne doit pas produire de brouillage et (2) l'utilisateur du dispositif doit être prêt à accepter tout brouillage radioélectrique reçu, même si ce brouillage est susceptible de compromettre le fonctionnement du dispositif.

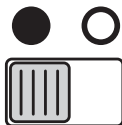

- Slide the power switch on the bottom of the building ON ● or OFF ○.

⚠ WARNING

Do not aim at eyes or face.
Only use projectiles supplied
with this toy.
Do not fire at point blank range.

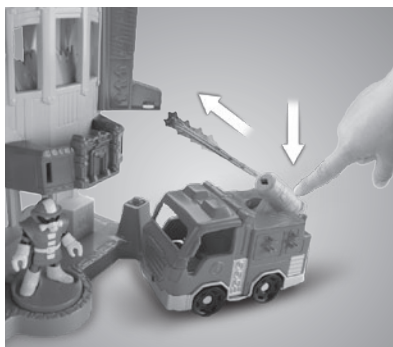

- Press the button to shoot “water” on the flames!



Turn a fi
the vault

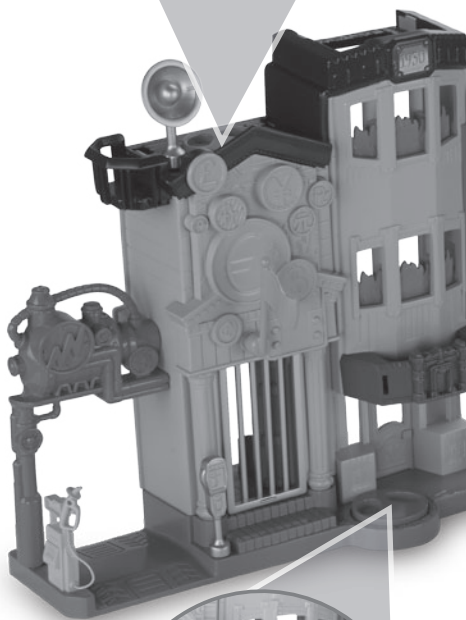

Turn
to p

Figure to open
the door.

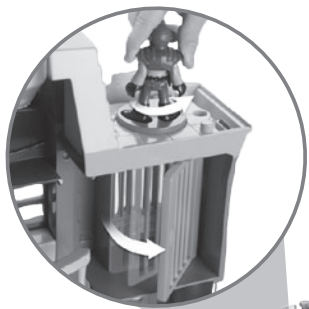

Turn the disk to
open and close the
jail door and activate
sounds/lights!



Turn a figure on the disk
to pop-up "flames".

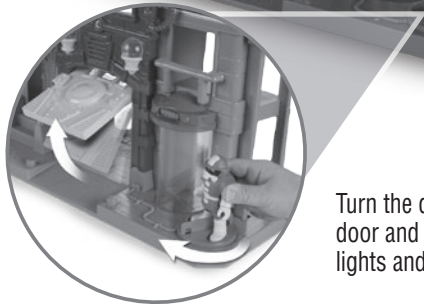

Turn the disk to open the
door and activate siren
lights and sounds!

Action Packed City!

The building recognizes the fire truck and responds!
Additional accessories sold separately and subject to availability.

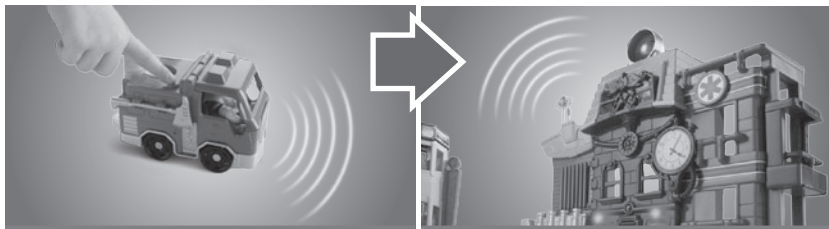

- Place the truck near the building.
- Press the button on the truck. Listen to the building respond.
- After about five minutes of no activity, the building will go into “sleep” mode. To wake up the building, simply turn a disk.

Hints:

- *The maximum response range between the building and the truck is 12 feet (3,7 m).*
- *Bright sunlight or fluorescent lights may affect the response range of the building. Try dimming the light in the room you are playing in.*
- *Make sure you have a clear path between the building and the truck.*