

TO PLAY

- 1. Rescue the trapped car.** 
- 2. Ride the outside lane and avoid the dragon's fire.** 
- 3. Ride the inside lane and get caught by the dragon.** 
- 4. Hit the central pillar to free car from dragon.** 

Warning: Do not aim at eyes or face. Only use projectiles supplied with this toy. Do not fire at point-blank range.

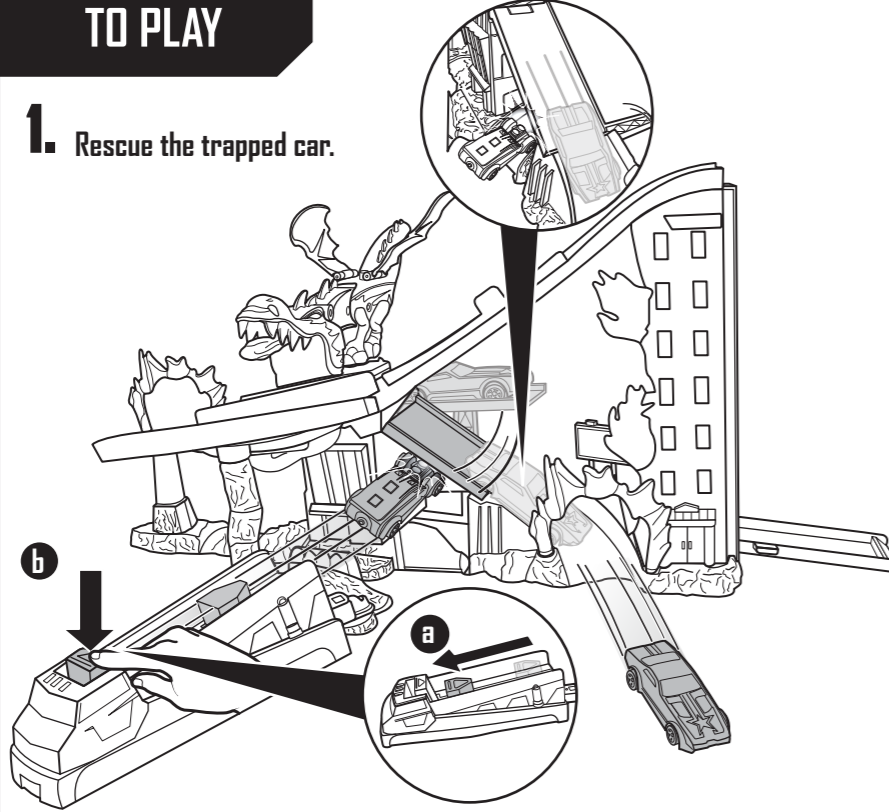
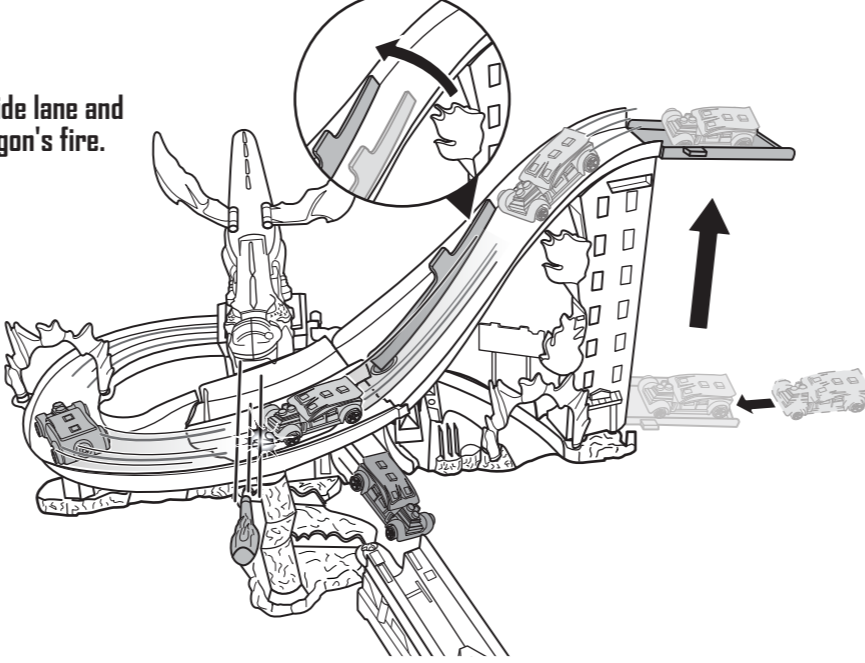
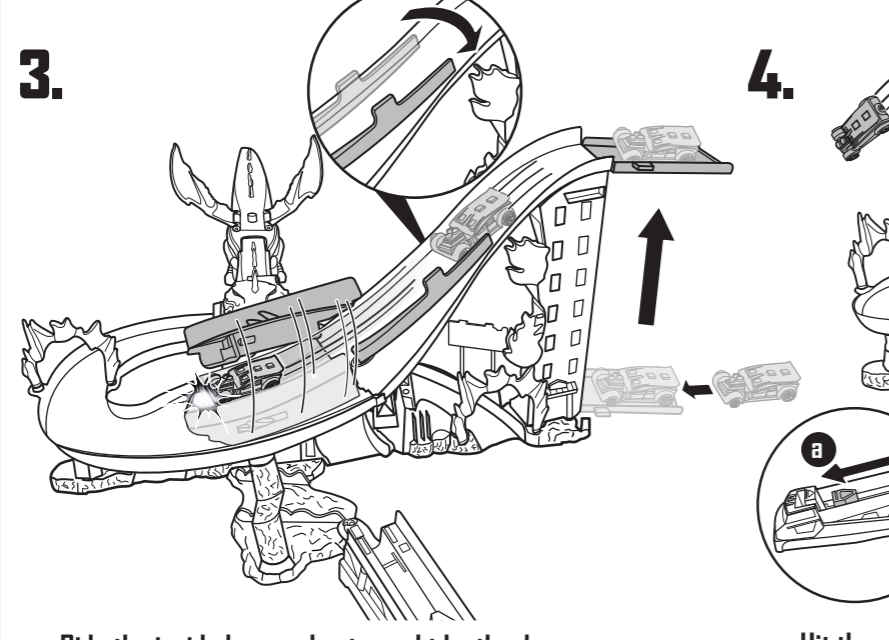
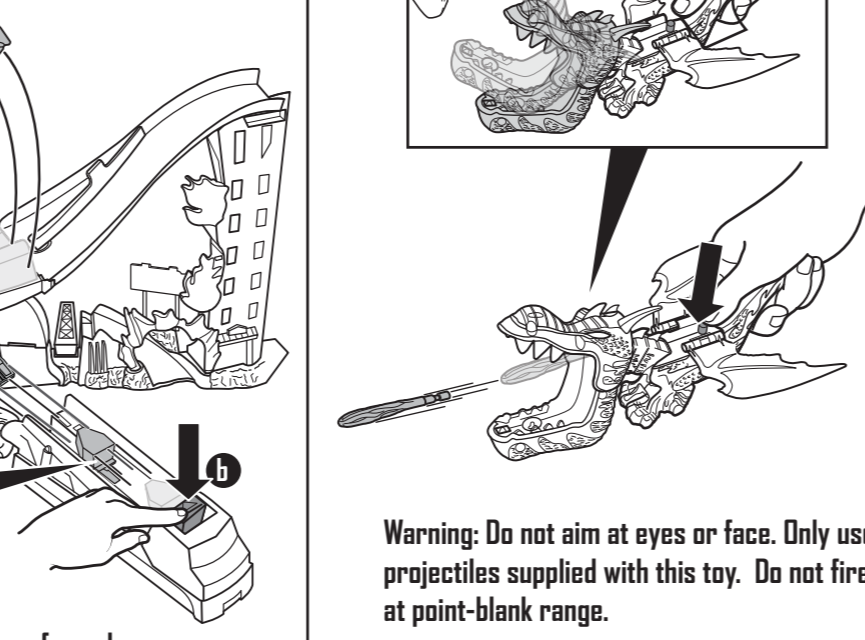

DRAGON DESTROYER™

INSTRUCTIONS

Please keep these instructions for future reference as they contain important information.

CONTENTS

4+ 

X9300-0920G1



WARNING: CHOKING HAZARD - Small parts. Not for children under 3 years.

©2012 Mattel. All Rights Reserved. Mattel, Inc., 636 Girard Avenue, East Aurora, NY 14052, U.S.A. Consumer Relations 1-800-524-8697. Mattel U.K. Ltd., Vanwall Business Park, Maidenhead SL6 4UB. Helpline 01628 500303. Mattel Australia Pty., Ltd., Richmond, Victoria, 3121. Consumer Advisory Service - 1300 135 312. Mattel East Asia Ltd., Room 1106, South Tower, World Finance Centre, Harbour City, Tsimshatsui, HK, China. Dimpont & Diedarkan Oleh: Mattel SEA Ptd Ltd. (993532-P) Lot 13.5, 13th Floor, Menara Lien Hoe, Perstaran Tropicana Golf Country Resort, 47410 P.J. Tel: 03-78803617, Fax: 03-78803667. service.mattel.com

INSTRUCTION SHEET SPECIFICATIONS

Toy: HW Ready To Play Set
 Part No.: X9300
 Part No.: 0920G1
 Trim Size: 16.5"W x 8.5" H
 Filled Size: 5.5" W x 8.5" H
 Type of Fold: Single
 # colors: One
 Colors: Black
 Paper Stock: White Offset
 Paper Weight: 70 lb.
 EDM No.:

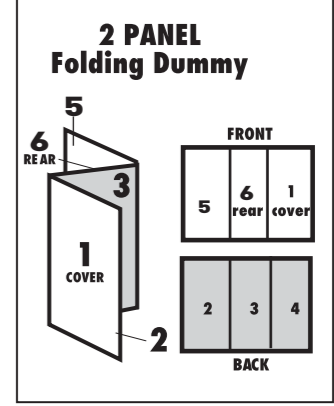

ASSEMBLY

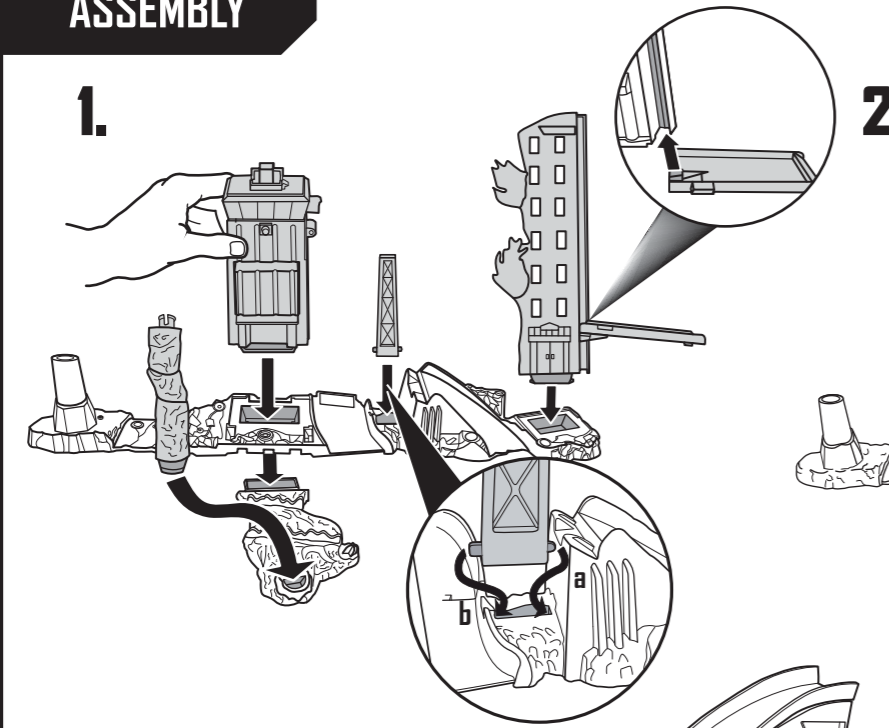
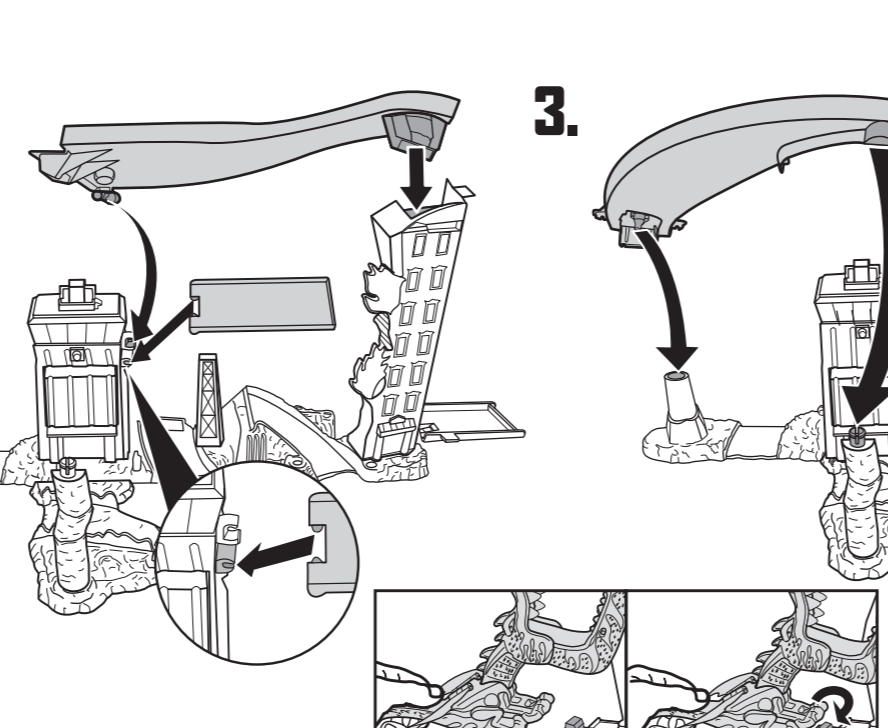
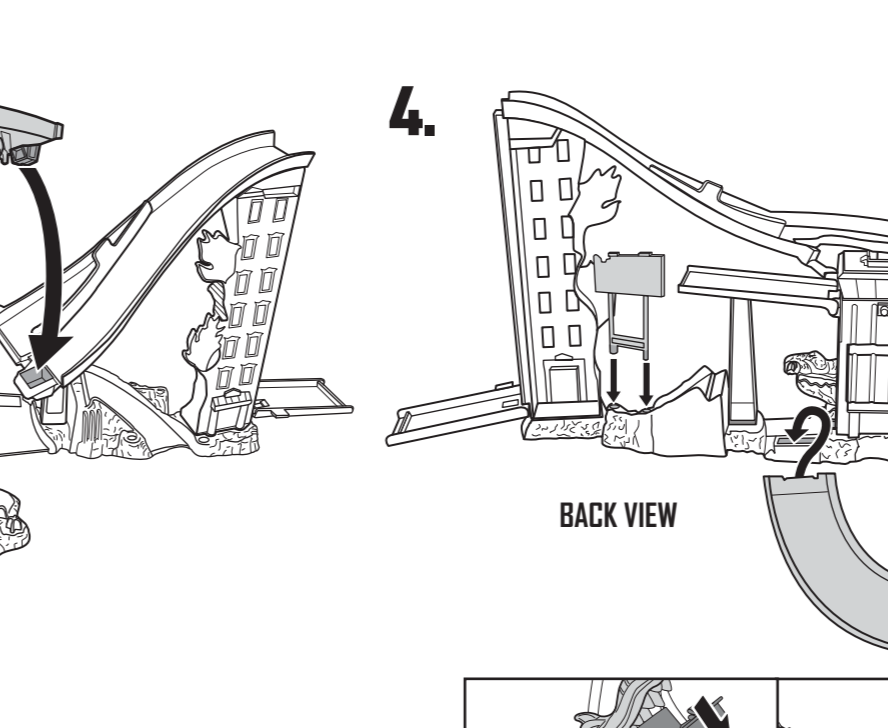
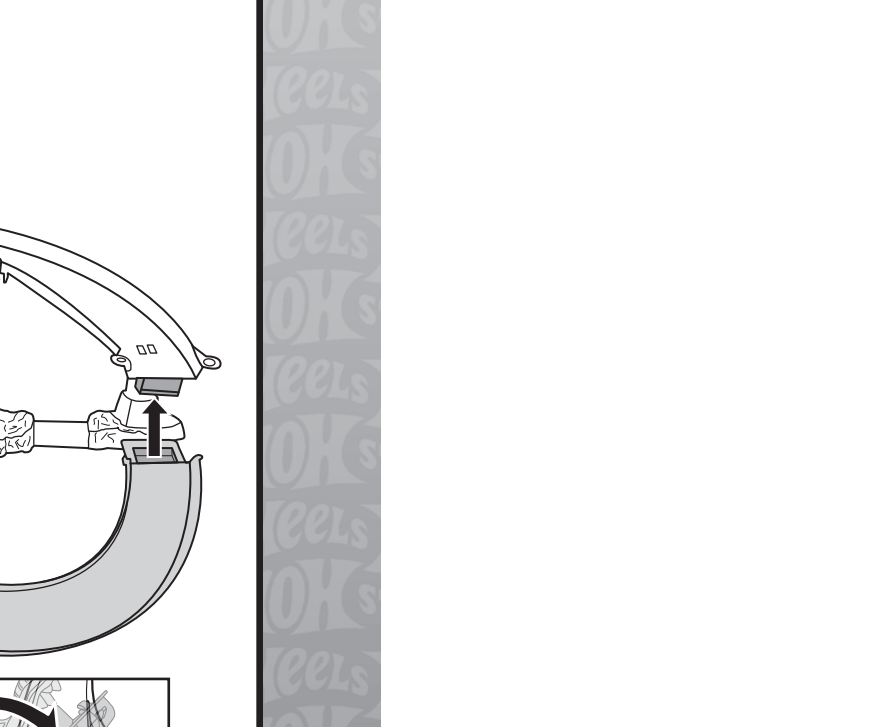
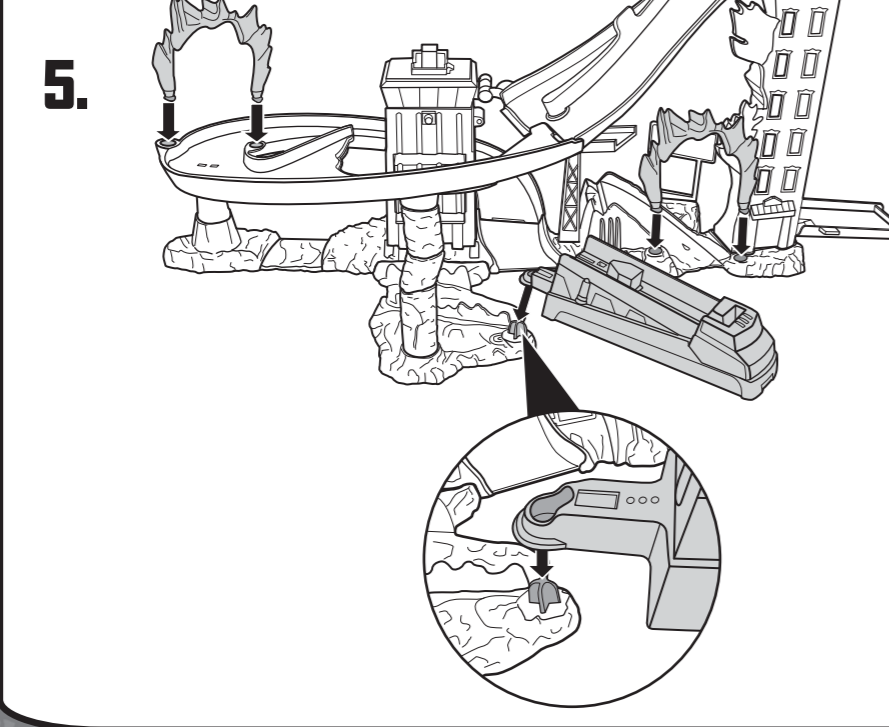
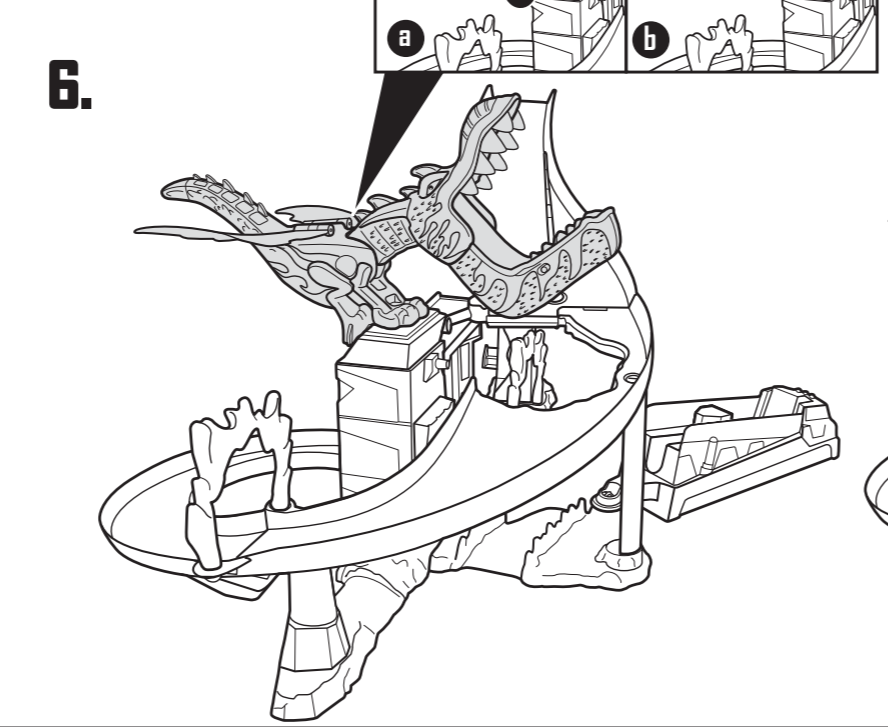
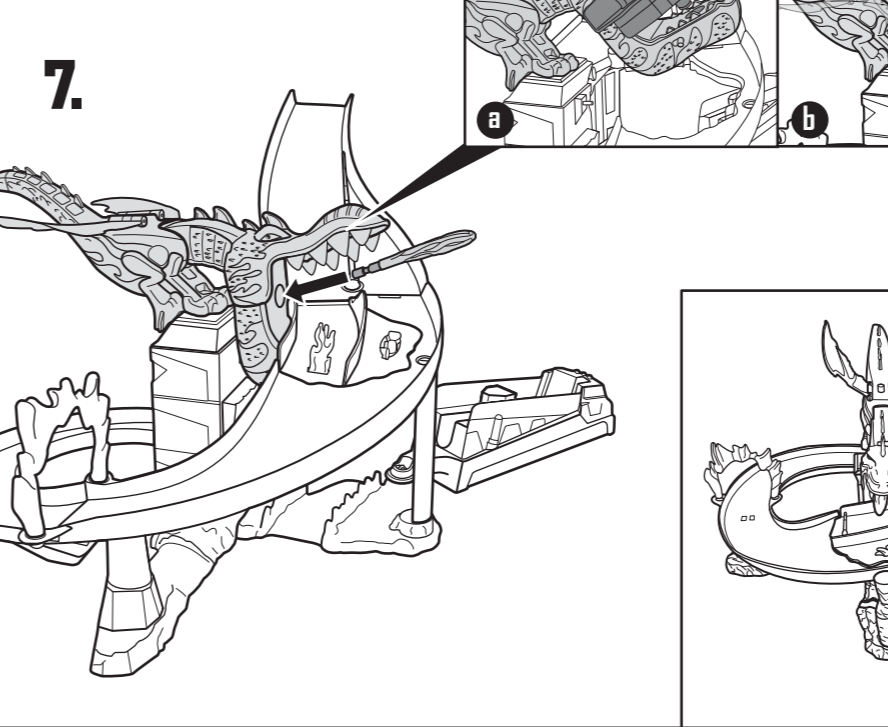
- 1.** 
- 2.** 
- 3.** 
- 4.** 
- 5.** 
- 6.** 
- 7.** 

BACK VIEW

