

Consumer Information



CONSUMER ASSISTANCE

1-800-432-5437 (US & Canada)
1300 135 312 (Australia)

service.fisher-price.com

Fisher-Price, Inc., 636 Girard Avenue, East Aurora, NY 14052.
Hearing-impaired consumers: 1-800-382-7470.

Outside the United States:

Canada: Mattel Canada Inc., 6155 Freemont Blvd.,
Mississauga, Ontario L5R 3W2; service.mattel.com.

Great Britain: Mattel UK Ltd, Vanwall Business Park,
Maldenhead SL6 4UB. Helpline: 01628 500303.
service.mattel.com/uk

Mattel Europa, B.V., Gondel 1, 1186 MJ Amstelveen, Nederland.

Australia: Mattel Australia Pty. Ltd., 658 Church Street,
Locked Bag #870, Richmond, Victoria 3121 Australia.

New Zealand: 16-18 William Pickering Drive,
Albany 1331, Auckland.



- Protect the environment by not disposing of this product with household waste (2002/96/EC). Check your local authority for recycling advice and facilities.

This Class B digital apparatus complies with Canadian ICES-003. Operation is subject to the following two conditions: (1) this device may not cause harmful interference and (2) this device must accept any interference received, including interference that may cause undesired operation.

Cet appareil numérique de la classe B est conforme à la norme NMB-003 du Canada. L'utilisation de ce dispositif est autorisée seulement aux conditions suivantes: (1) il ne doit pas produire de brouillage et (2) l'utilisateur du dispositif doit être prêt à accepter tout brouillage radioélectrique reçu, même si ce brouillage est susceptible de compromettre le fonctionnement du dispositif.

Assembled Parts

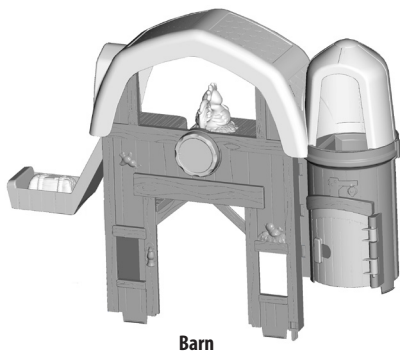

Barn



Ladder



Shed

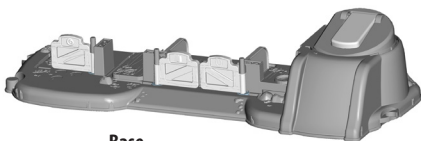

Base



#6 x 3/4" (1,9 cm) Screw - 2

SHOWN ACTUAL SIZE

Tighten and loosen all screws with a Phillips screwdriver. Do not over-tighten.

Battery Replacement

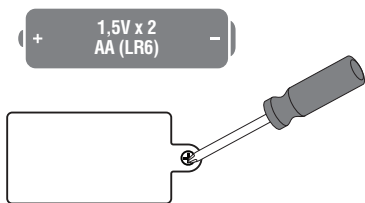

For best performance, we recommend replacing the batteries that came with this toy with two, new AA (LR6) batteries. Use alkaline batteries for longer life.

- Loosen the screw in the battery compartment door and remove the door.
- Remove the exhausted batteries and dispose properly.
- Insert two, new AA (LR6) **alkaline** batteries.
- Replace the battery compartment door and tighten the screw.

Battery Safety Information

In exceptional circumstances, batteries may leak fluids that can cause a chemical burn injury or ruin your product. To avoid battery leakage:

- Do not mix old and new batteries or batteries of different types: alkaline, standard (carbon-zinc) or rechargeable (nickel-cadmium).
- Insert batteries as indicated inside the battery compartment.
- Remove batteries during long periods of non-use. Always remove exhausted batteries from the product. Dispose of batteries safely. Do not dispose of this product in a fire. The batteries inside may explode or leak.
- Never short-circuit the battery terminals.
- Use only batteries of the same or equivalent type, as recommended.
- Do not charge non-rechargeable batteries.

- Remove rechargeable batteries from the product before charging.
- If removable, rechargeable batteries are used, they are only to be charged under adult supervision.

FCC Statement (United States Only)

This equipment has been tested and found to comply with the limits for a Class B digital device, pursuant to Part 15 of the FCC Rules. These limits are designed to provide reasonable protection against harmful interference in a residential installation. This equipment generates, uses and can radiate radio frequency energy and, if not installed and used in accordance with the instructions, may cause harmful interference to radio communications. However, there is no guarantee that interference will not occur in a particular installation. If this equipment does cause harmful interference to radio or television reception, which can be determined by turning the equipment off and on, the user is encouraged to try to correct the interference by one or more of the following measures: Reorient or relocate the receiving antenna. Increase the separation between the equipment and receiver. Consult the dealer or an experienced radio/TV technician for help. Changes or modifications not expressly approved by the manufacturer responsible for compliance could void the user's authority to operate the equipment. This device complies with Part 15 of the FCC Rules. Operation is subject to the following two conditions: (1) this device may not cause harmful interference and (2) this device must accept any interference received, including interference that may cause undesired operation.

Fisher-Price®

Y3677



Please keep this instruction sheet for future reference, as it contains important information.

Requires two AA batteries (included) for operation.

Batteries included are for demonstration purposes only.

Adult assembly is required. Tool required: Phillips screwdriver (not included).

Wipe this toy with a clean, damp cloth. Do not immerse.

This toy has no consumer serviceable parts. Do not take apart.

fisher-price.com

Assembly



CAUTION

This package contains small parts.
For adult assembly only.

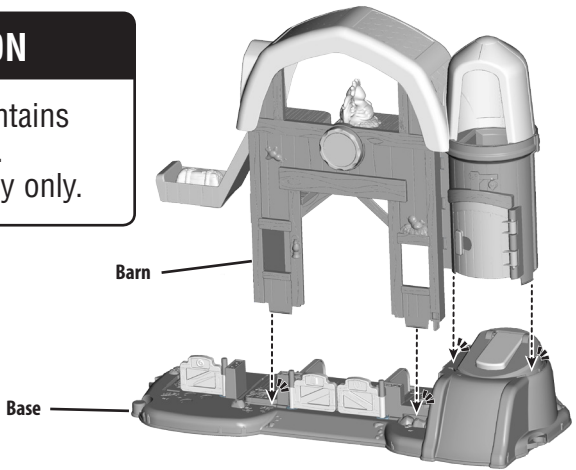

1

- Fit the tabs on the bottom of the barn into the base. Push to **“snap”** in place.

Ladder

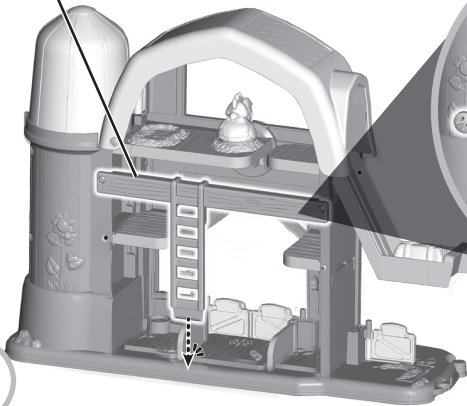

2

- Fit the tab on the ladder into the slot in the base. Push to **“snap”** in place.
- Insert two screws into the ladder and tighten.

Assembly

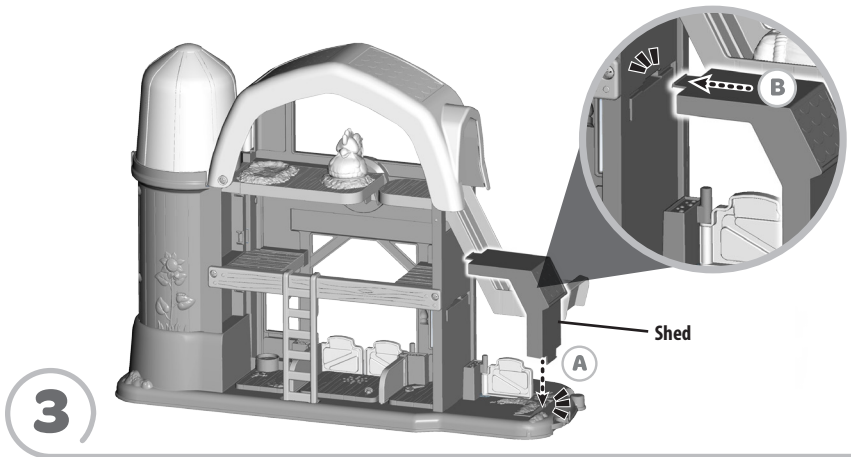

- First, fit the tab on the bottom of the shed into the slot in the base (A). Push to “snap” in place.
- Next, fit the tab on the top of the shed into the slot in the barn wall (B). Push to “snap” in place.

Re-Assembly

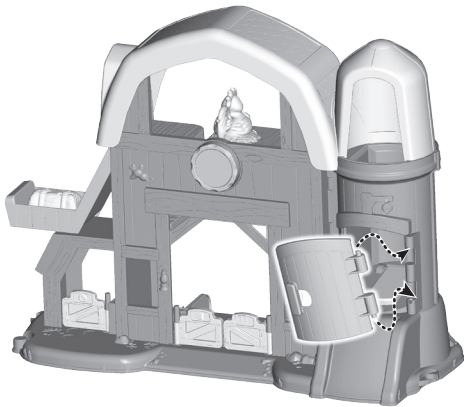

Hint: The silo door is designed to break away from the barn. If it falls off, simply re-assemble it to the barn.

- At an angle, fit the tab on the door hinge into the slot in the door frame.
- Push to “snap” the other door hinge in place.

Lots of activities, sounds and songs!



Slide the power switch on the bottom of the toy to ON ● or OFF ○.

Open and close the door or drop a hay bale through the silo for fun animal sounds!

Turn the dial for day or night mode. Hear different songs and sounds in each mode!

- If this toy begins to operate erratically, you may need to reset the electronics. Slide the power switch off and back on.
- When sounds become faint or stop, it's time for an adult to change the batteries.

Connect the fence pieces and gate to build a corral for the animals!