



MIGHTY MINIS™ SHOWDOWN STADIUM™

INSTRUCTIONS

4+



Y6749-0920

Please keep these instructions for future reference as they contain important information.

CONTENTS

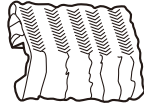
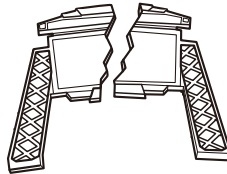
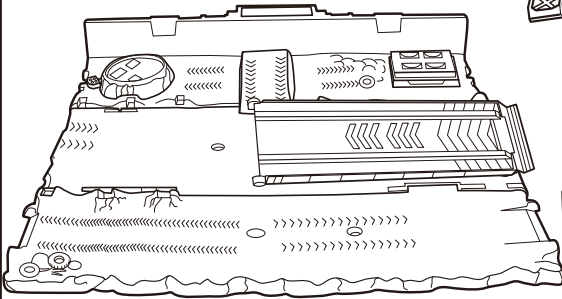

X 3



X 2

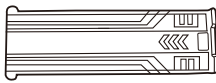
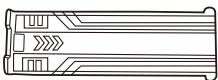

© 2013 Feld Motor Sports, Inc.

Monster Jam®, United States Hot Rod Association®, USHRA®, Afterburner®, Backwards Bob®, Blacksmith®, Blue Thunder®, Bulldozer®, Captain's Curse®, Dragon's Breath®, El Toro Loco®, Grave Digger®, Grave Digger The Legend®, Grinder™, Crusader™, Maximum Destruction®, Mohawk Warrior®, Monster Mutt®, Northern Nightmare™ and Son-uva Digger® are trademarks used under license by FMS. All rights reserved.

©2013 Mattel. All Rights Reserved. Mattel, Inc., 636 Girard Avenue, East Aurora, NY 14052, U.S.A. Consumer Relations 1-800-524-8697. Mattel U.K. Ltd., Vanwall Business Park, Maidenhead SL6 4UB. Helpline 01628 500303. Mattel Australia Pty., Ltd., Richmond, Victoria. 3121. Consumer Advisory Service - 1300 135 312. Mattel East Asia Ltd., Room 503-09, North Tower, World Finance Centre, Harbour City, Tsimshatsui, HK, China. Diimport & Diedarkan Oleh: Mattel SEA Ptd Ltd.(993532-P) Lot 13.5, 13th Floor, Menara Lien Hoe, Persiaran Tropicana Golf Country Resort, 47410 PJ. Malaysia. Tel:03-78803817, Fax:03-78803867. service.mattel.com

ASSEMBLY

1.

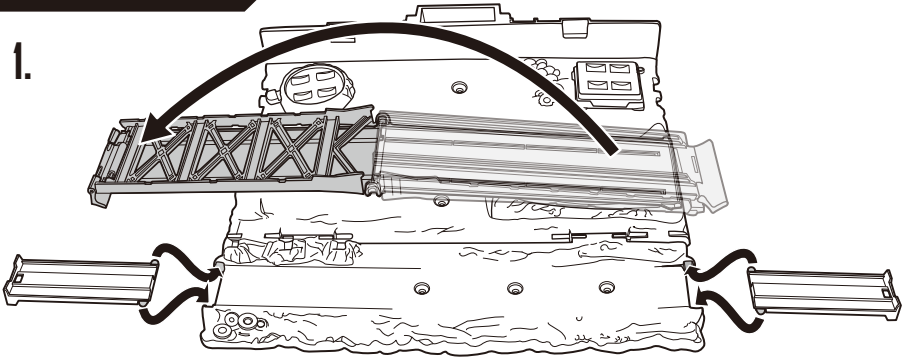

2.

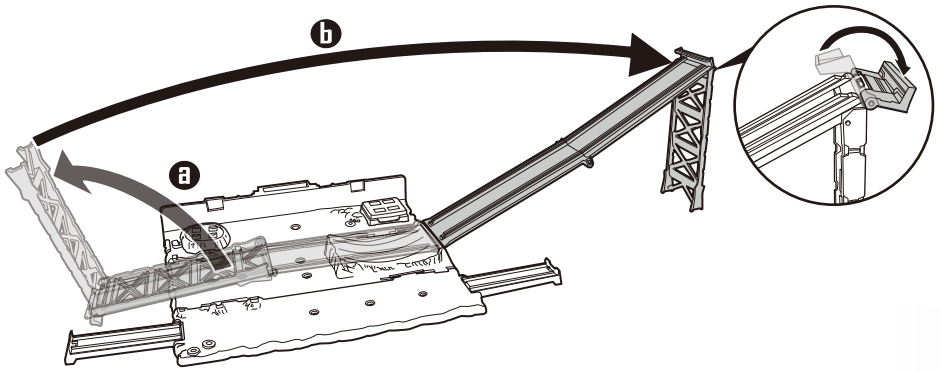

3.

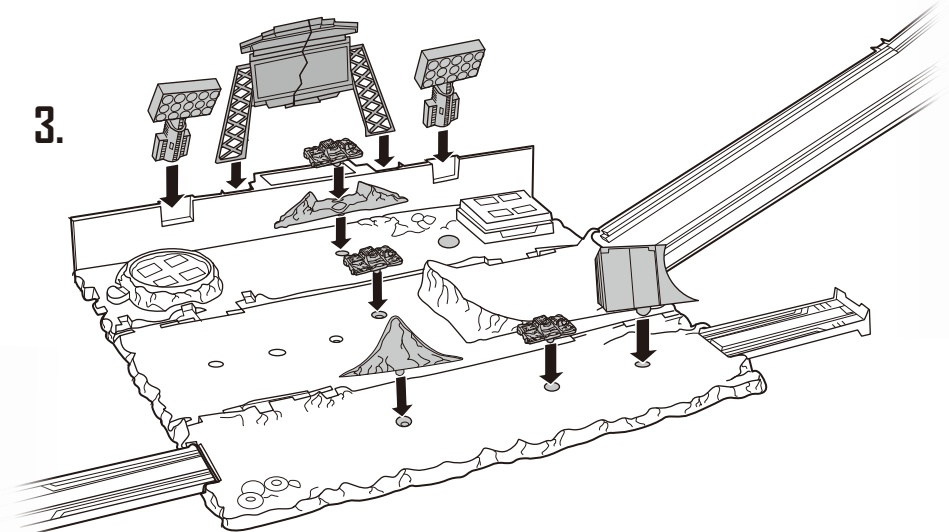

4.

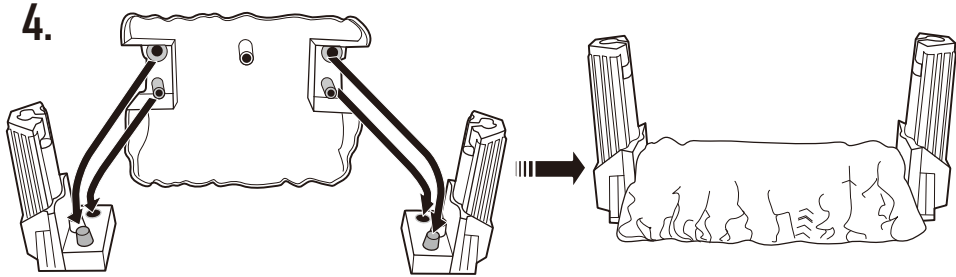

5.

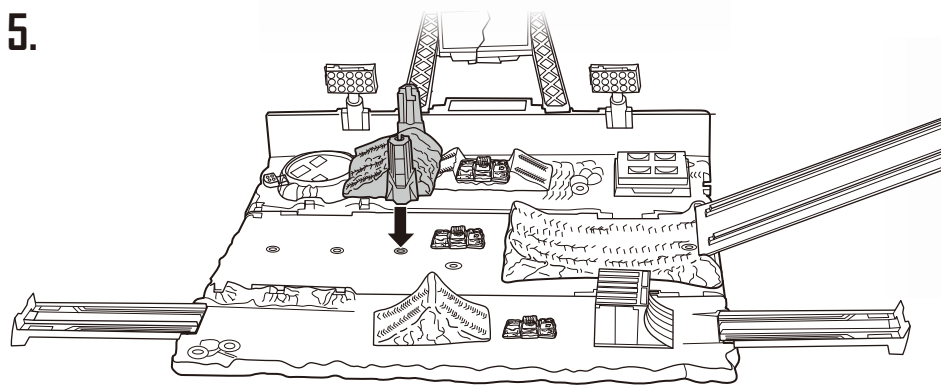

6.

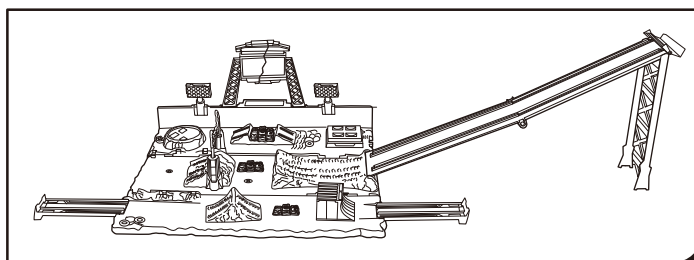
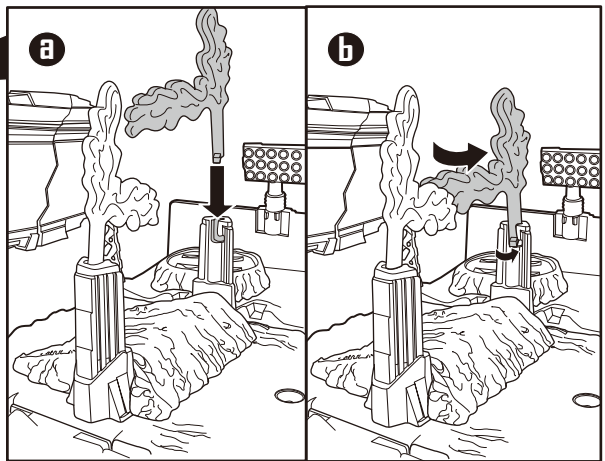
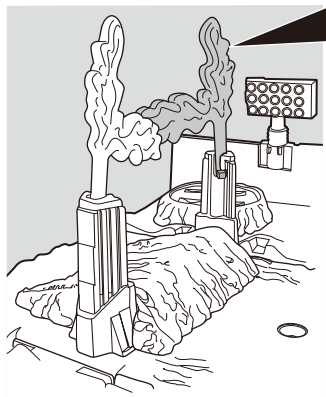

TO PLAY

1.

a

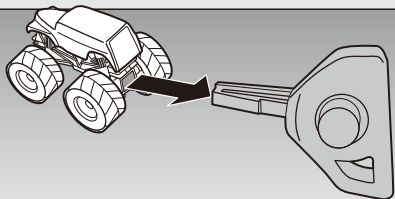

b

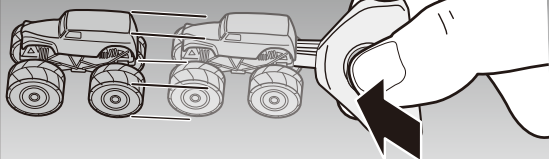

2.

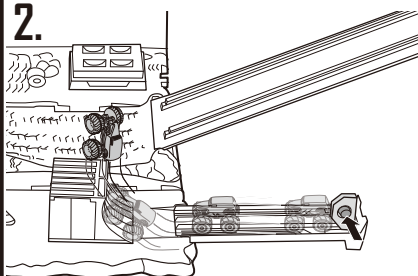

3.

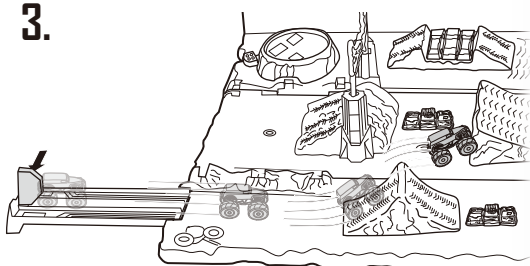

4. Load trucks. Lift platform for fair start.

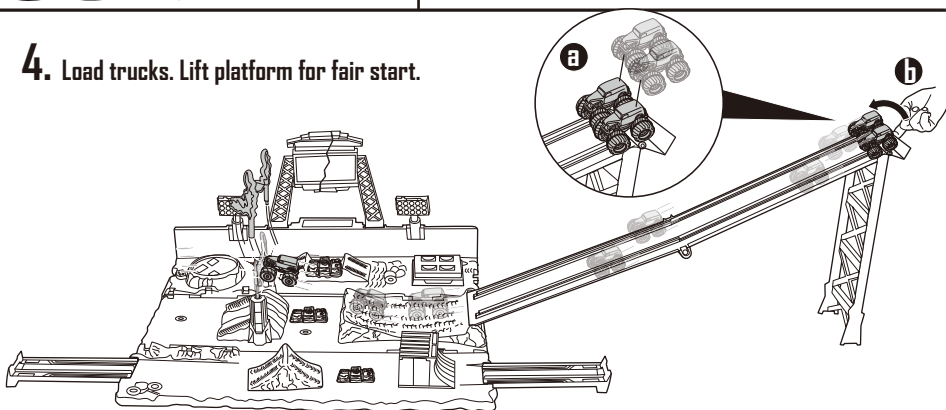

5. Test your skills. Move landing ramp further back.

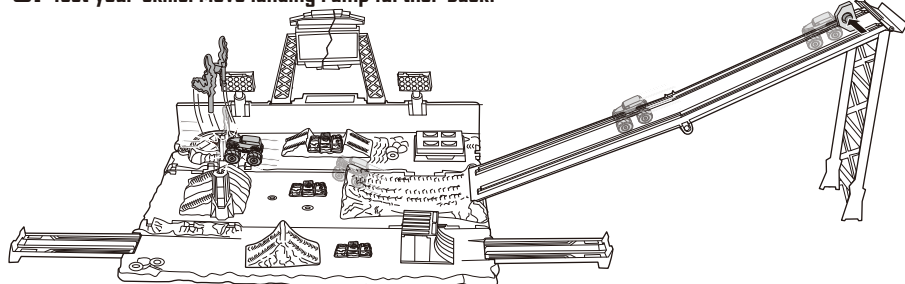

Warning: Do not aim at eyes or face. Only use projectiles intended for use with this toy. Do not fire at point-blank range.

6.

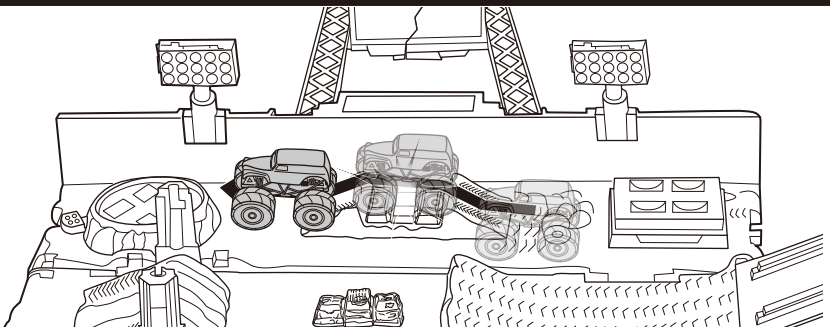

7.

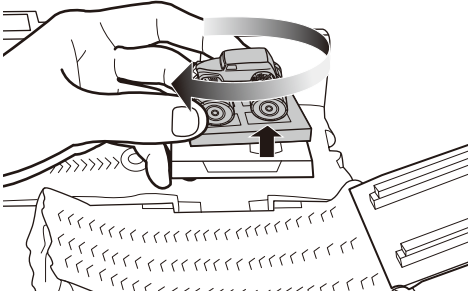

8.

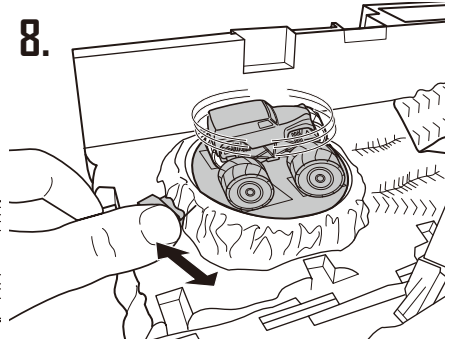

9. Move the stunts and accessories around to create your own set up!

a

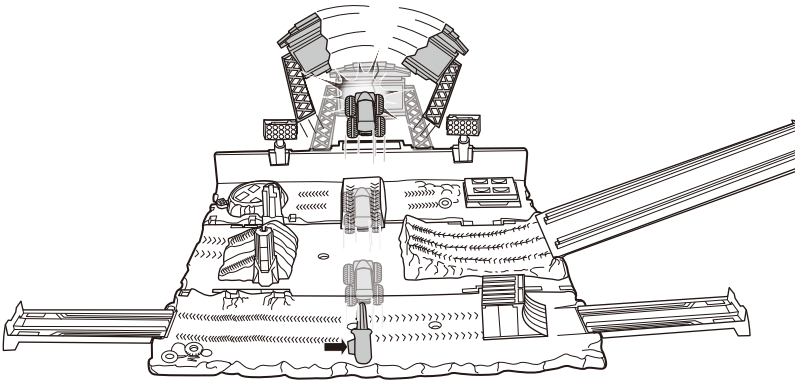

b

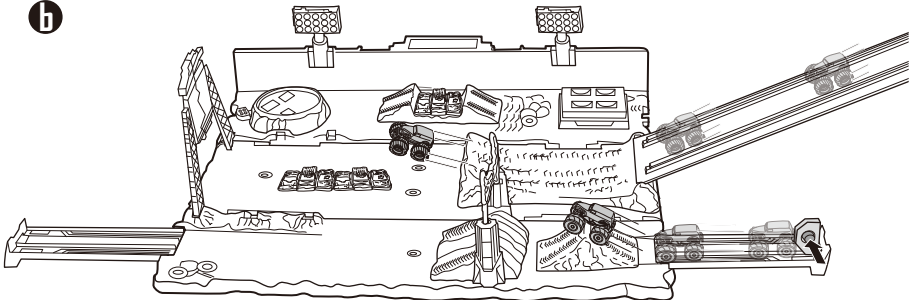

STORAGE

1.

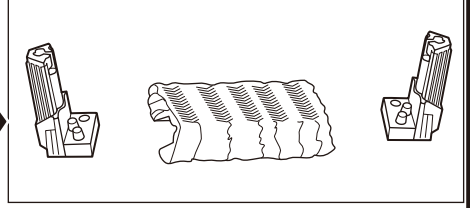
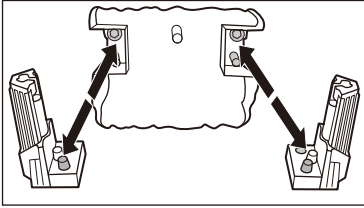

2.

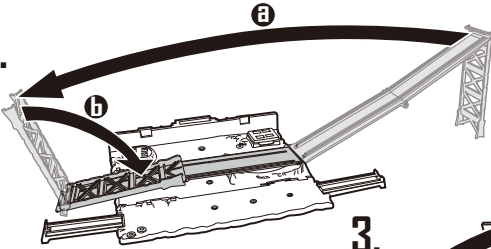

3.

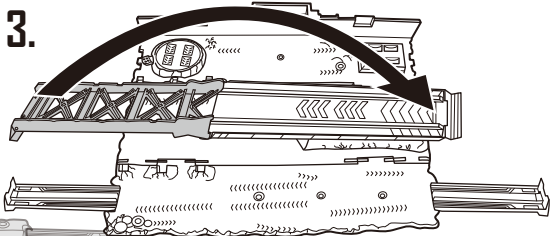

4.

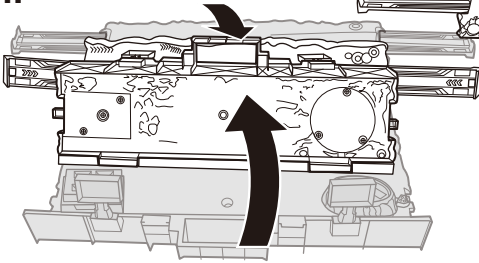

5.

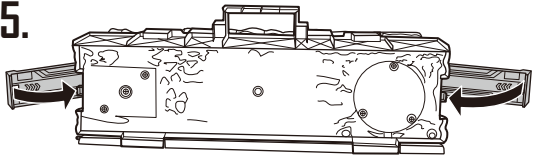

6.

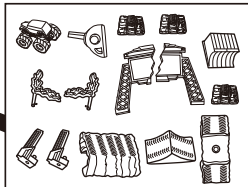
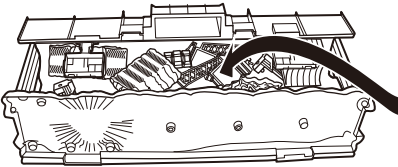

7.

