

TECH TRAX™

THE ADVANCED CONSTRUCTION SYSTEM FOR ULTIMATE STUNTS



Cool cars, games and more!

• Mattel, Inc., El Segundo, CA 90245 U.S.A. Consumer Affairs 1 (800) 524-TOYS.
• Mattel U.K. Ltd., Vanwall Business Park, Maidenhead SL6 4UB. Helpline 01628500303.
• Mattel Australia Pty., Ltd., Richmond, Victoria. 3121. Consumer Advisory Service - 1300 135 312.

• Mattel East Asia Ltd., Room 1106, South Tower, World Finance Centre, Harbour City, Tsimshatsui, HK, China.
• Diimport & Diedarkan Oleh: Mattel SEA Ptd Ltd.(993532-P) Lot 13.5, 13th Floor, Menara Lien Hoe, Persiaran Tropicana Golf Country Resort, 47410 PJ. Tel:03-78803817, Fax:03-78803867.



TECH TRAX™

THE ADVANCED CONSTRUCTION SYSTEM FOR ULTIMATE STUNTS

POWER SWING™ STUNT SET



INSTRUCTIONS

8+

B4686-0920



© 2004 Mattel, Inc. All Rights Reserved.

PARTS

Twist off cap and empty contents

(1) STO & GO™

(1) Lid Connector

(4) 90°-Joints

(1) Spiral Caddy

(1) SC-Exit

(1) SC-Entry

(1) Swing Rod

(1) Small Support

(2) 14" (35.5 cm) Guardrails

(2) 20" (51 cm) Guardrails

(3) R-9

(1) R-4

(1) R-6

(2) S-12

(1) S-9

(2) Base Supports

(22) Clips

(1) T2P
(Adaptor for connecting to other tracks)

TECH TRAX™ BUILDING BASICS

Clips attach to tracks as shown. Notches on clips align with tabs on tracks to lock in proper position.

Press guardrails into clips until they snap and lock.

Track marking system.

Rod marking system.

All track connections lock together with the TECH TRAX™ system. Be sure tabs insert fully to lock tracks together properly as shown.

To unlock tracks, press in on locking tabs and pull apart at the same time as shown.

1

HORIZONTAL/ VERTICAL SUPPORT AND CONNECTORS

Parts required:

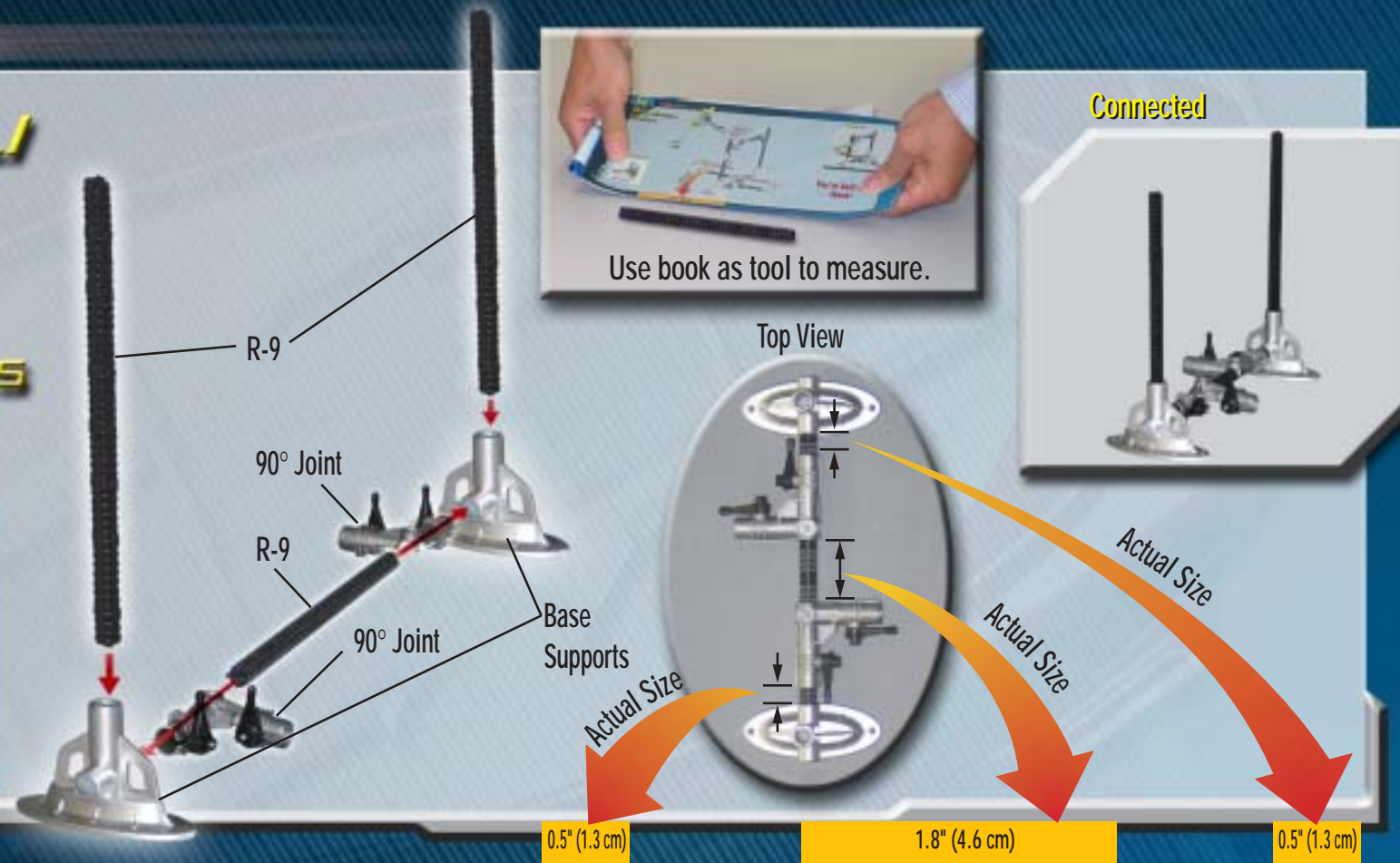

3

2

CONNECT HORIZONTAL RODS AND RAMP

Parts required:



4

3

ADD CONNECTORS AND ADJUST SPACING

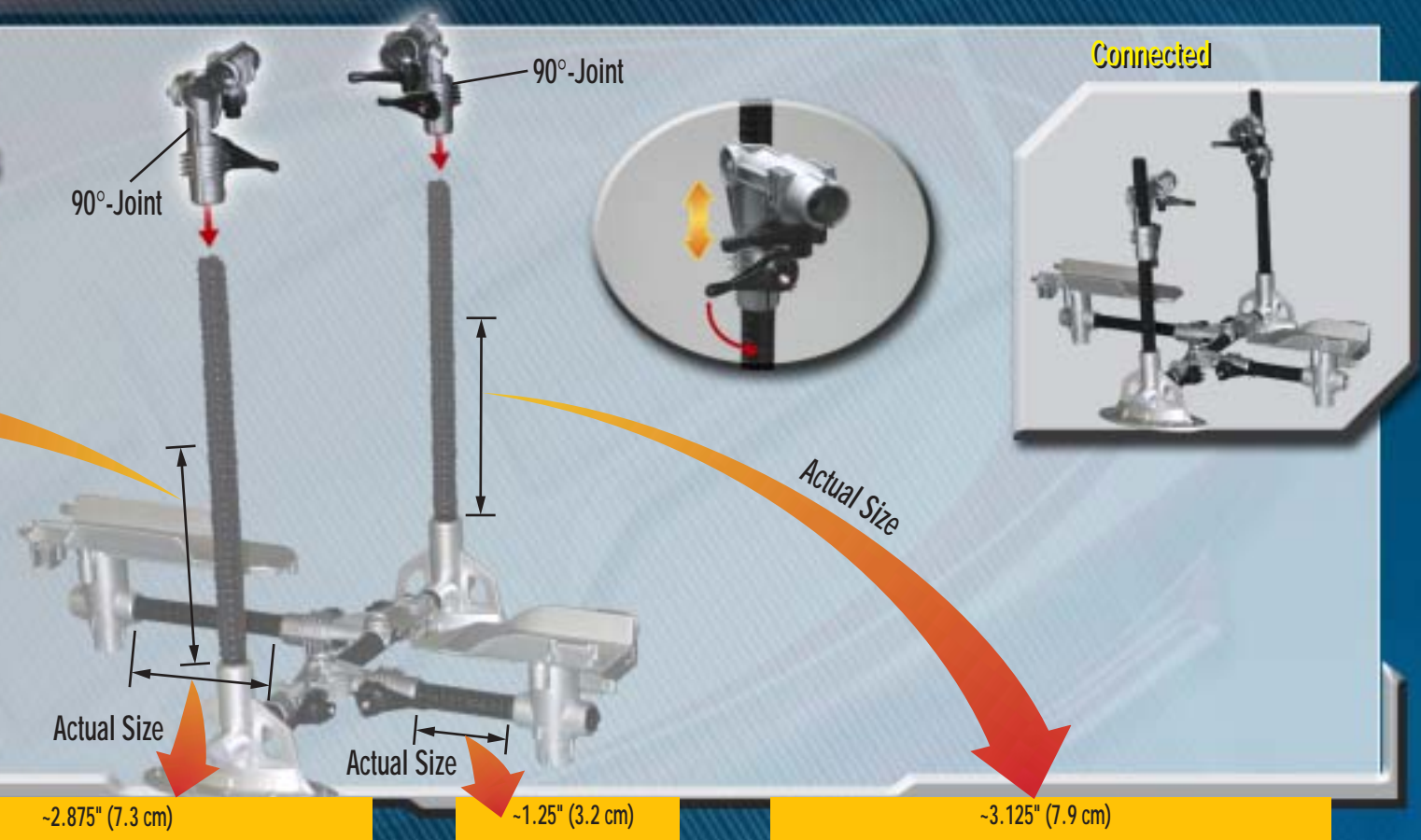

-3.125" (7.9 cm)

Parts required:



-2.875" (7.3 cm)

-1.25" (3.2 cm)

-3.125" (7.9 cm)

4

ATTACH SWING ROD



6

5

Add SPIRAL CADDY



Connected



You're half way there!

Parts required:



Spiral Caddy

7

6

Add TRACKS



Connected

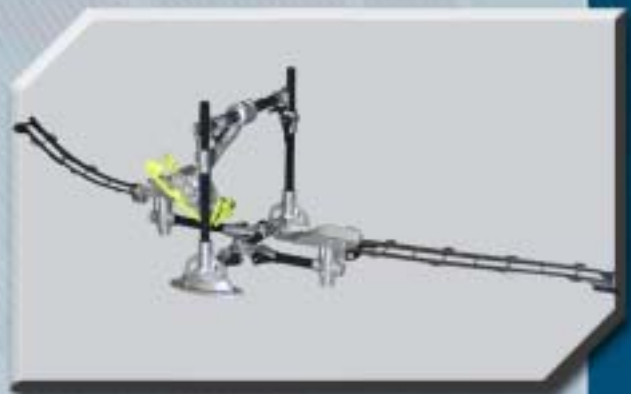

Parts required:



S-9

S-12

S-12

8

7

Add Top Track

S-12

Parts required:



Connected

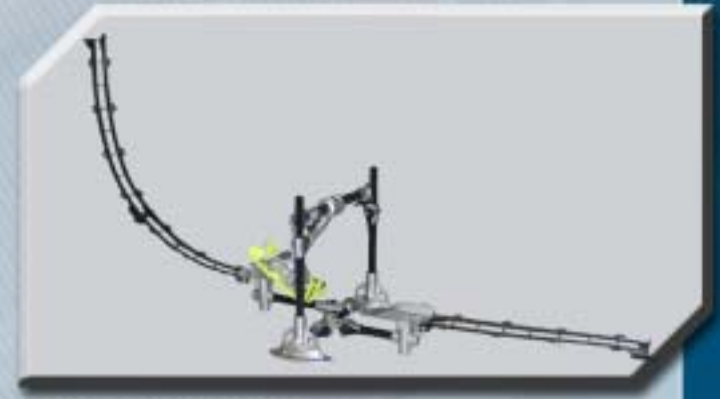

8

CONNECT TRACK TO THE STO & GO™ LID

Side View

Lid Connector

STO & GO™

Parts required:



Connected



9

Add CLIPS

Parts required:

- (22) Clips
-

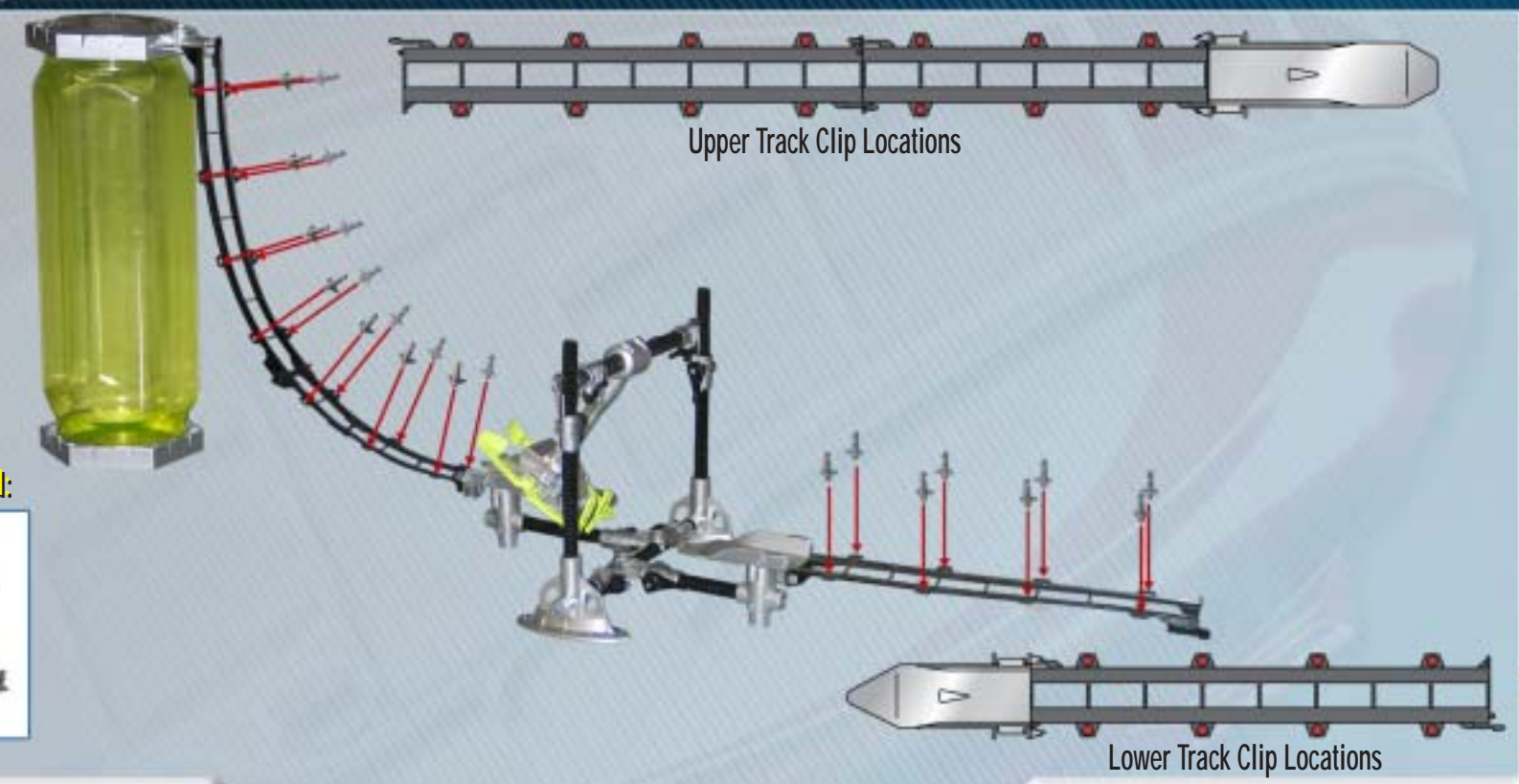

10

INSTALL GUARDRAILS

Parts required:

- (2) 14" (35.5 cm)
 - (2) 20" (51 cm)
-

Note: Use of tape (not included) can improve performance and help stabilize the set.

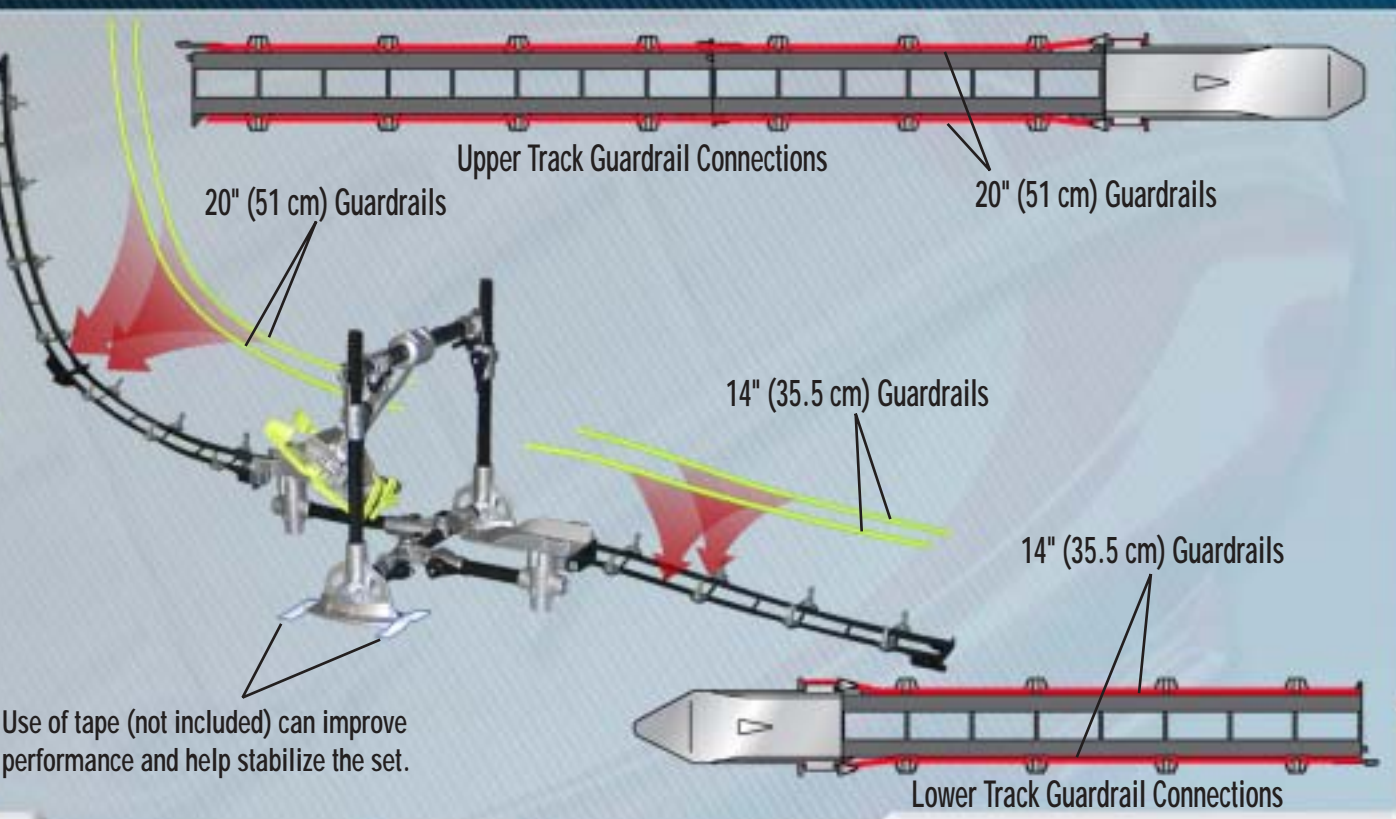

FINISHED SET



Note: Tape (not included) may be used to help stabilize POWER SWING™.

Tape

Congratulations!
 Your **TECH TRAX™ POWER SWING™** set is complete.
"You're a TECH TRAX™ Master."
 Now choose your car,
 and you're ready to test your skill!

14" (35.5 cm) Guardrail

20" (51 cm) Guardrail

ALTERNATE LAYOUT

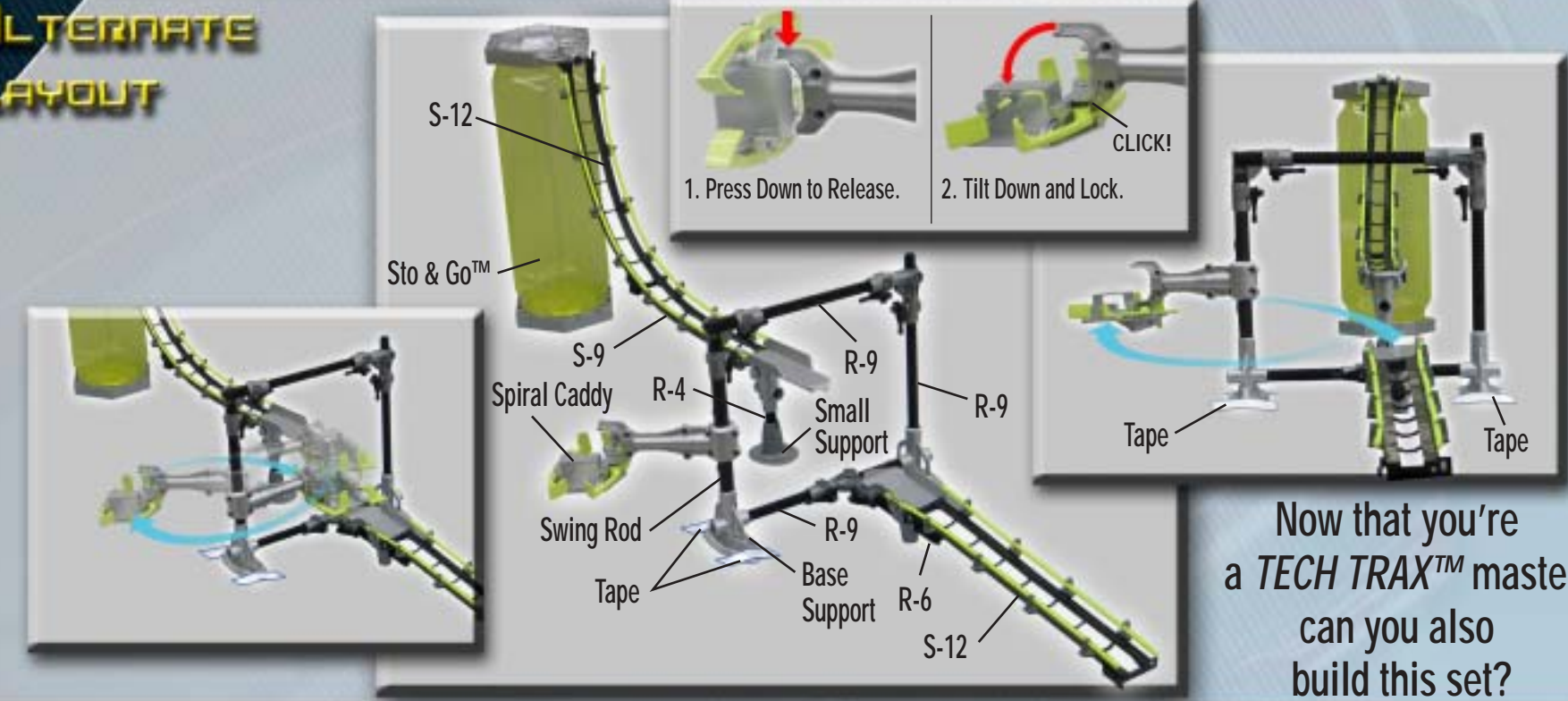

Now that you're
 a **TECH TRAX™** master
 can you also
 build this set?

READY TO PLAY

HOW TO PLAY

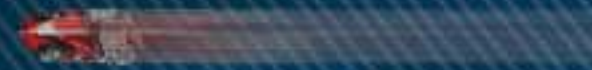

To Lock Spiral Caddy in Center Position



1. Pull Forward



2. Back and Lock

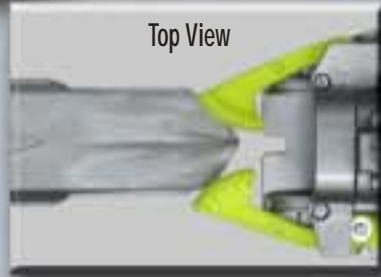

Release Car Here

Vehicles not included.

Car Will Twist Around in Spiral Caddy and Continue Onto Other End of Track

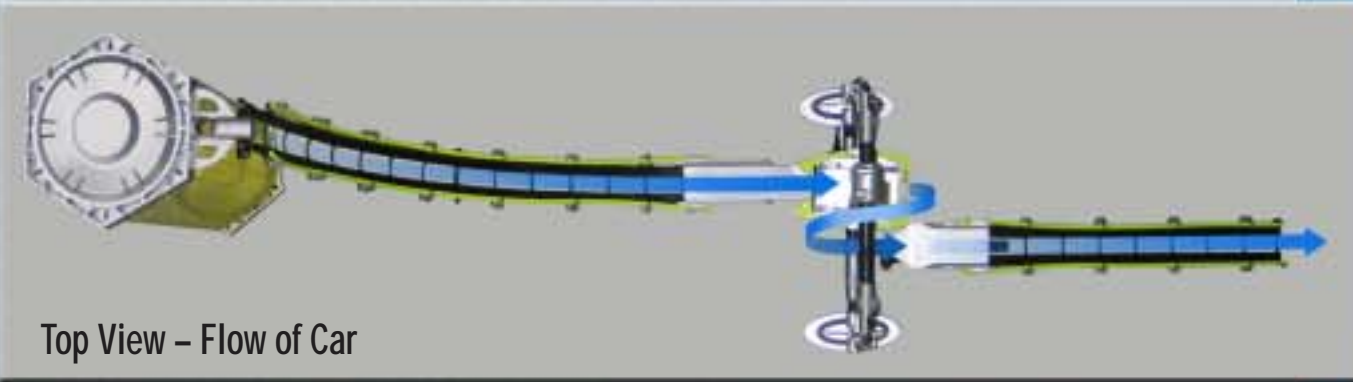

Top View - Flow of Car

FINISH!

AFTER PLAY TROUBLESHOOTING AND TIPS

STO & GO™!

All the pieces of your track set can be easily stored inside the unique STO & GO™ package! Place larger items back in canister first.



Where Guardrail ends, be sure to carefully flex the ends outward, so that it won't impede the vehicles movement.



The T2P connector can be used as an adaptor for connecting the track pieces of TECH TRAX™, to existing Hot Wheels® track.



To use the 3XL, simply slide it onto one of the Rod pieces. (Note: Be sure the "Locking Key" is in the open position.)

Position along the rod where desired, and then turn the Lock key to secure.



To use the 45/90/T-Joints, simply slide a Rod into the open face of the joint, and then close over the cover element. (Note: Be sure the "Joint Key" is rotated into its "open" position.) To lock its position on the rod, rotate the Joint Key 90 degrees.

Fine tuning of the set is required to yield optimum performance.



To attach the track, take the section where two tracks are joined, and simply slide into the rotating clip unit.

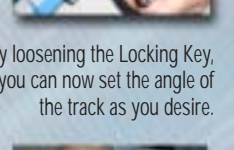

By loosening the Locking Key, you can now set the angle of the track as you desire.



To remove the track from the Rotating Clip, simply squeeze its ends outward, and pull track out of the groove.



COLLECT AND CONNECT TECH TRAX™ SETS



G3736 Flex Loop™ Stunt Set



B4687 Trigger Flip™ Stunt Set

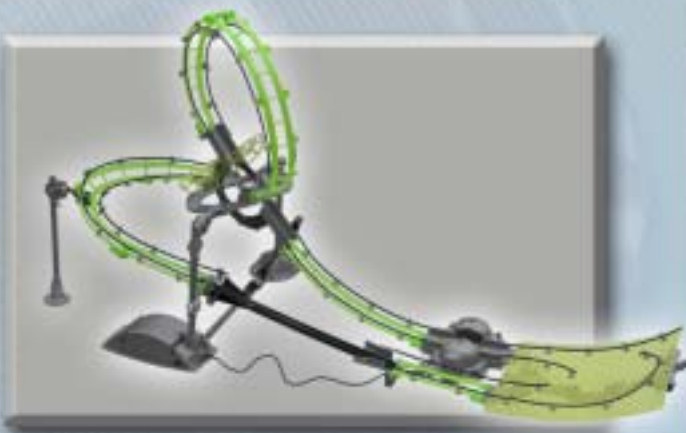

B6529 Crash Chamber™ Stunt Set

AVAILABLE CARS:



B4681 Jump Master™



B4682 Turbo Torque™



B4683 Power Pivot™

Each sold separately, subject to availability. Colors and decorations may vary.



TECH TRAX™

THE ADVANCED CONSTRUCTION SYSTEM FOR ULTIMATE STUNTS

B4686-0900



8+

POWER SWING™

STUNT SET

- | | | |
|------------------------------|-------------------|--------------------|
| (2) 14" (35.5 cm) Guardrails | (1) Lid Connector | (1) SC-Exit |
| (2) 20" (51 cm) Guardrails | (1) R-4 | (1) Spiral Caddy |
| (4) 90° Joints | (1) R-6 | (1) STO & GO™ |
| (2) Base Supports | (3) R-9 | (1) Swing Rod |
| (22) Clips | (2) S-12 | (1) SC-Entry |
| (1) Small Support (not used) | (1) S-9 | (1) T2P (not used) |

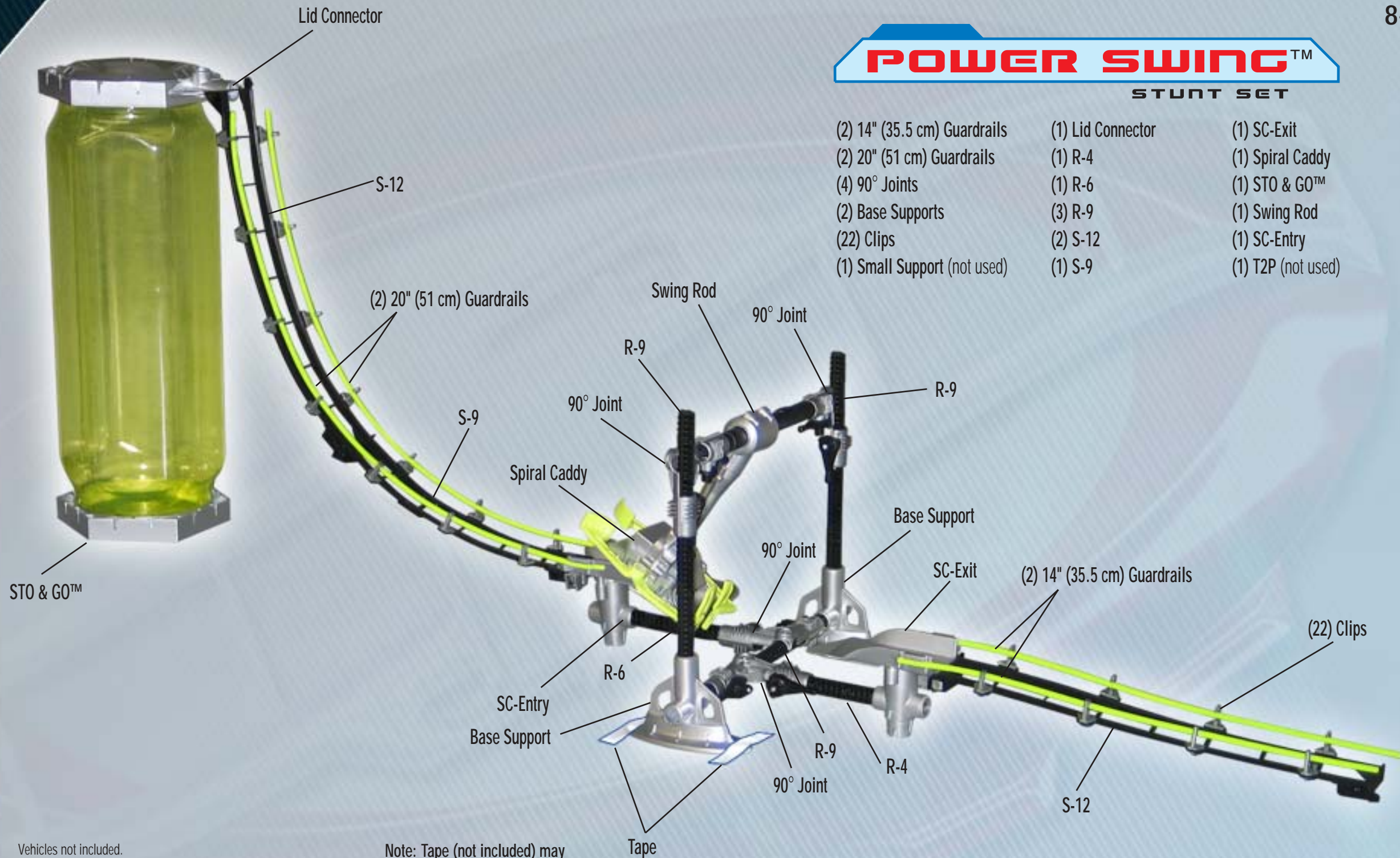

Vehicles not included.
Not for use with some Hot Wheels® Vehicles.

© 2004 Mattel, Inc. All Rights Reserved.

Note: Tape (not included) may
be used to help stabilize
POWER SWING™.

TECH TRAX™

THE ADVANCED CONSTRUCTION SYSTEM FOR ULTIMATE STUNTS



• Mattel, Inc., El Segundo, CA 90245 U.S.A. Consumer Affairs 1 (800) 524-TOYS.
• Mattel U.K. Ltd., Vanwall Business Park, Maidenhead SL6 4UB. Helpline 01628500303.
• Mattel Australia Pty., Ltd., Richmond, Victoria. 3121. Consumer Advisory Service - 1300 135 312.

• Mattel East Asia Ltd., Room 1106, South Tower, World Finance Centre, Harbour City, Tsimshatsui, HK, China.
• Diimport & Diedarkan Oleh: Mattel SEA Ptd Ltd.(993532-P) Lot 13.5, 13th Floor, Menara Lien Hoe, Persiaran Tropicana Golf Country Resort, 47410 PJ. Tel:03-78803817, Fax:03-78803867.



8+



TECH TRAX™

THE ADVANCED CONSTRUCTION SYSTEM FOR ULTIMATE STUNTS

TRIGGER FLIP™ STUNT SET



INSTRUCTIONS

© 2004 Mattel, Inc. All Rights Reserved.

PARTS

Twist off cap and empty contents

(1) Trigger Flip™

(1) Sleeve

(4) Lid Connectors

(1) Coupler

(1) 45° Joint

(1) Landing Pad Support

(1) Landing Pad

(2) 11" (28 cm) Guardrails

(2) 24" (61 cm) Guardrails

(1) R-12

(1) R-9

(2) R-6

(2) R-4

(2) S-12

(1) S-6

(1) Aux. Base

(1) T2P (Adaptor for connecting to other tracks)

(24) Clips

(1) STO & GO™

TECH TRAX™ BUILDING BASICS

Clips attach to tracks as shown. Notches on clips align with tabs on tracks to lock in proper position.

Press guardrails into clips until they snap and lock.

Track marking system.

Rod marking system.

All track connections lock together with the TECH TRAX™ system. Be sure tabs insert fully to lock tracks together properly as shown.

To unlock tracks, press in on locking tabs and pull apart at the same time as shown.

1

ASSEMBLE LANDING PLATFORM

Center Support

Landing Pad Support

Connected

R-6

Forward

End View

Aux. Base

Forward

Parts required:



3

2

LANDING PLATFORM CONTINUED

Parts required:



Landing Pad

Side View

Pull back ears under platform

Snap!

Top View

Connected

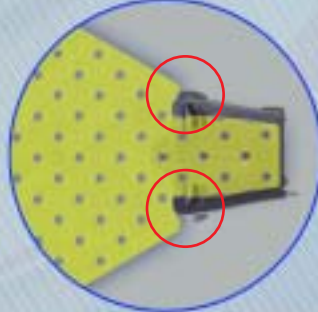
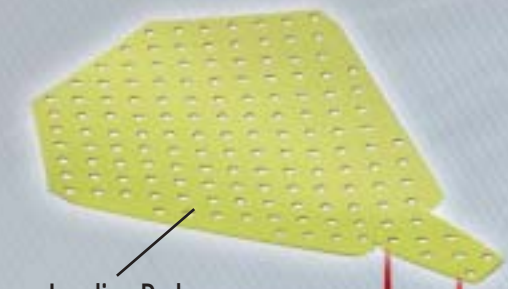

4

3

CONNECT TRACK

Parts required:



Connected



5

4

CONNECT SPACER

Parts required:

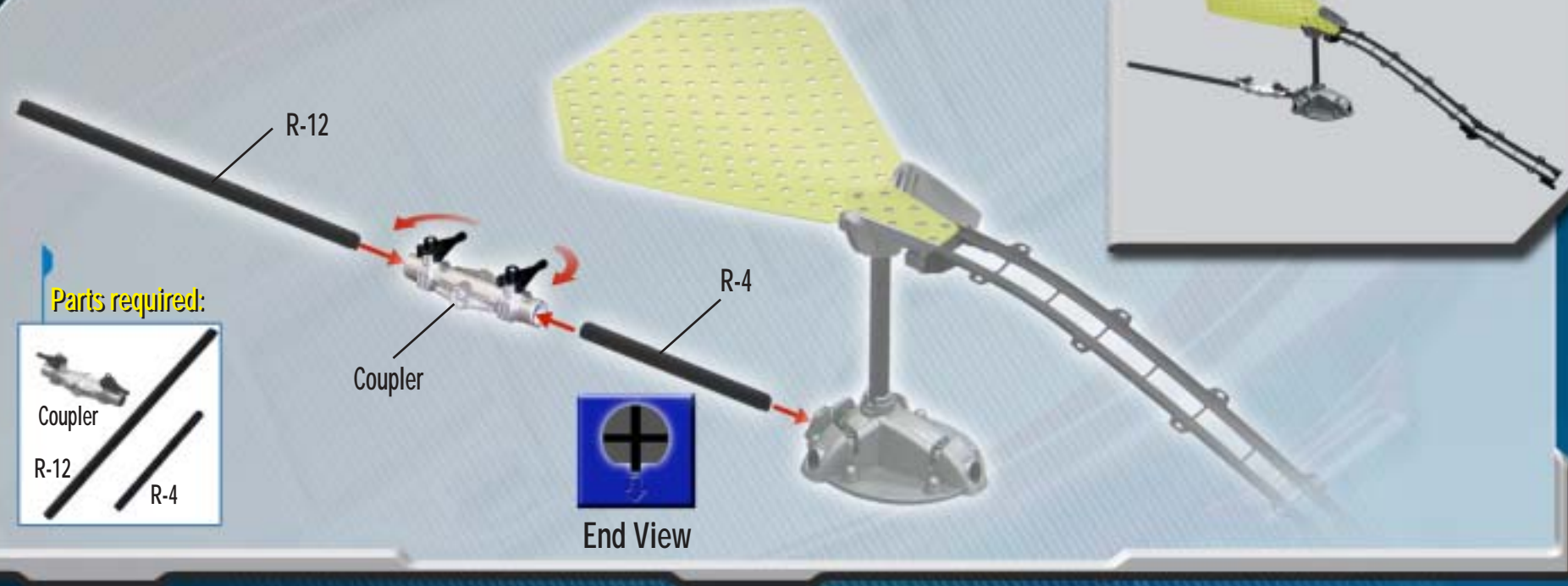
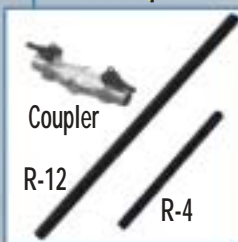

Connected



6

5

CONNECT STO & GO™ TOWER SUPPORT

Parts required:

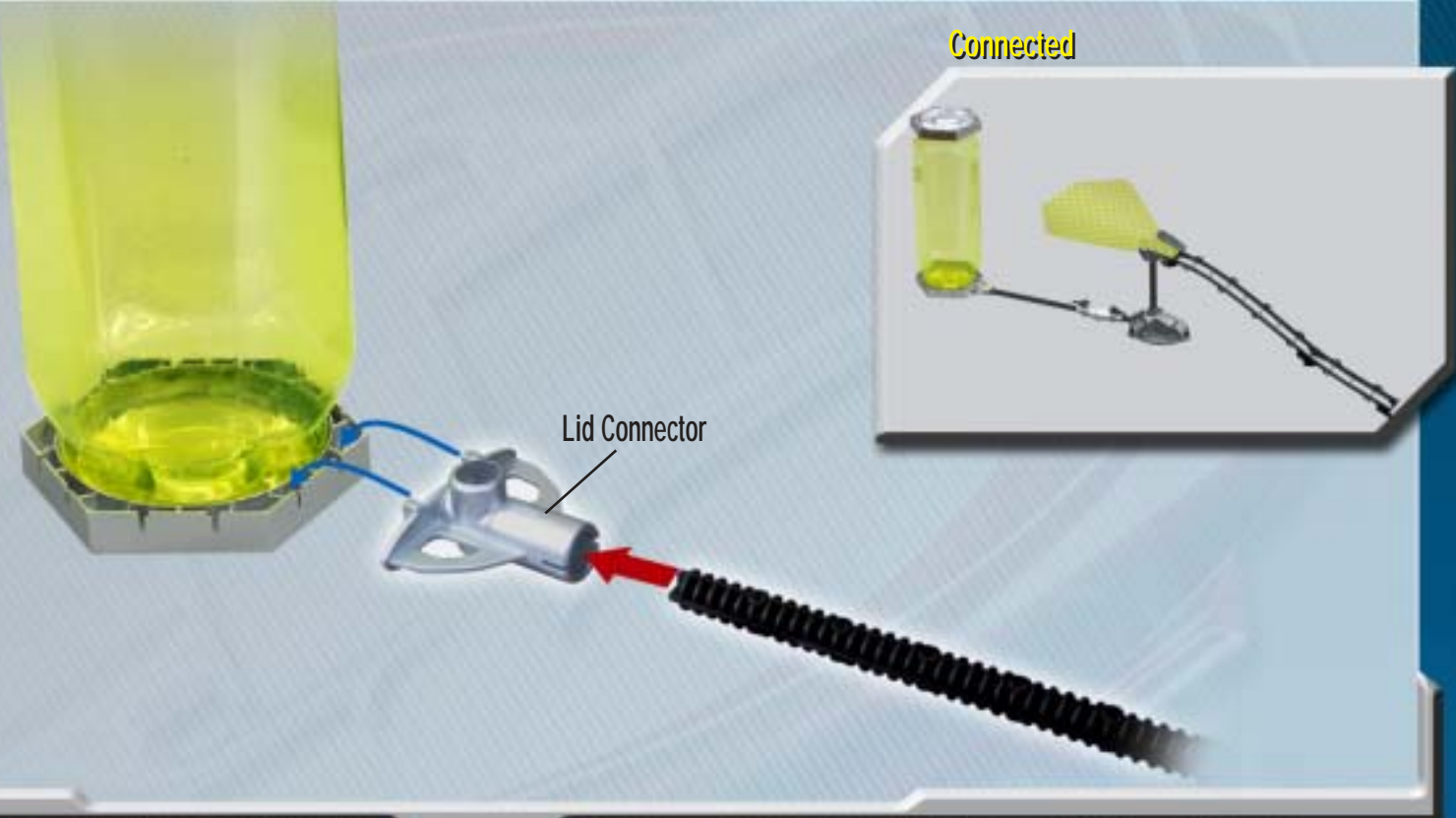

6

ADD JUMP RAMP

Parts required:

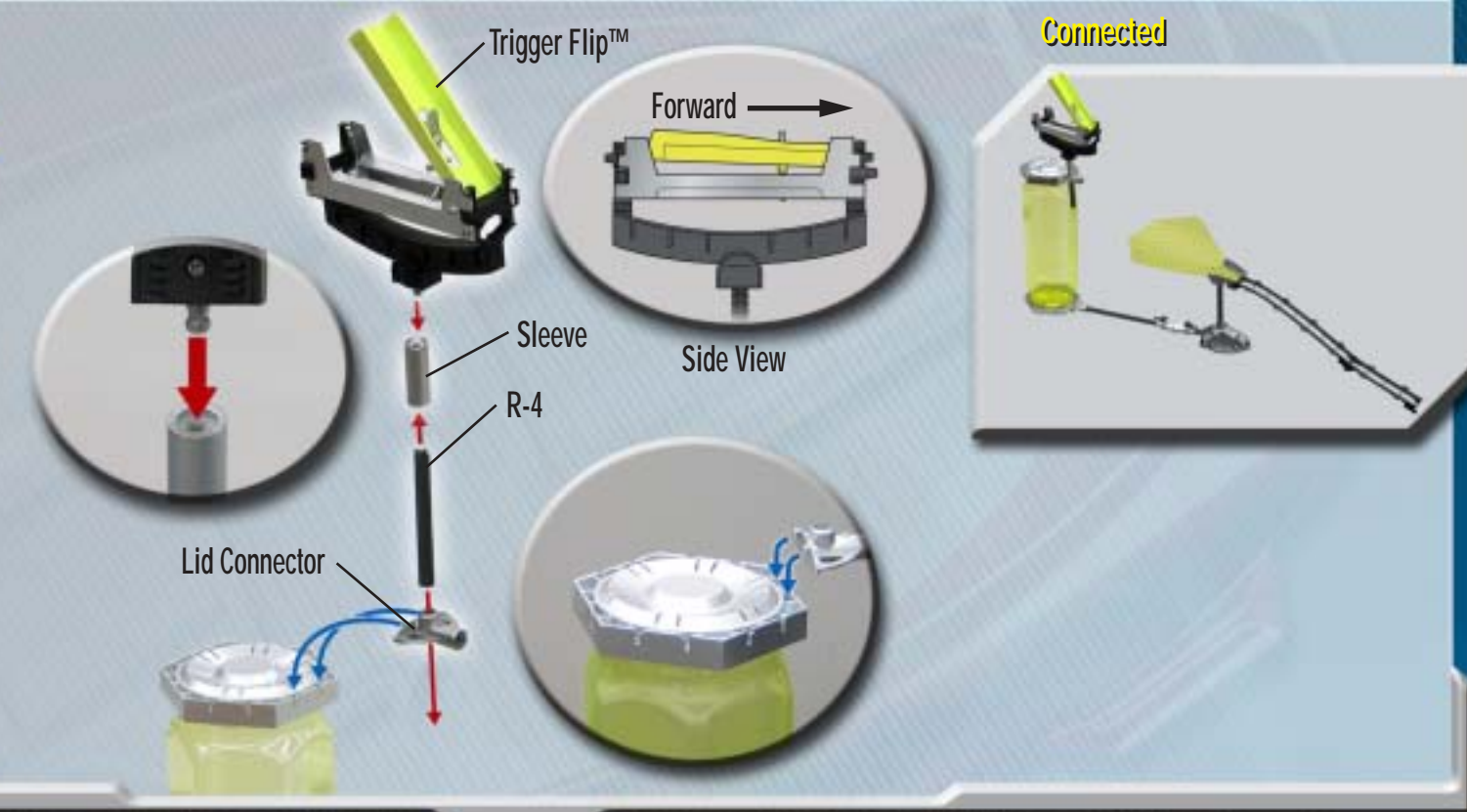

7

Add Tower Support

Parts required:

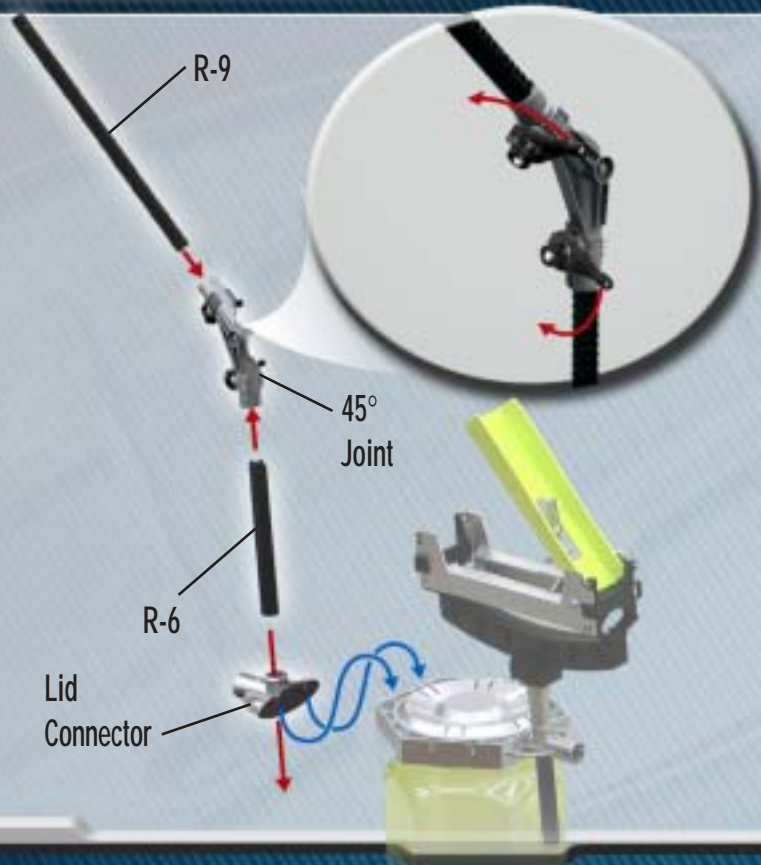

8

Add Top Track

Parts required:

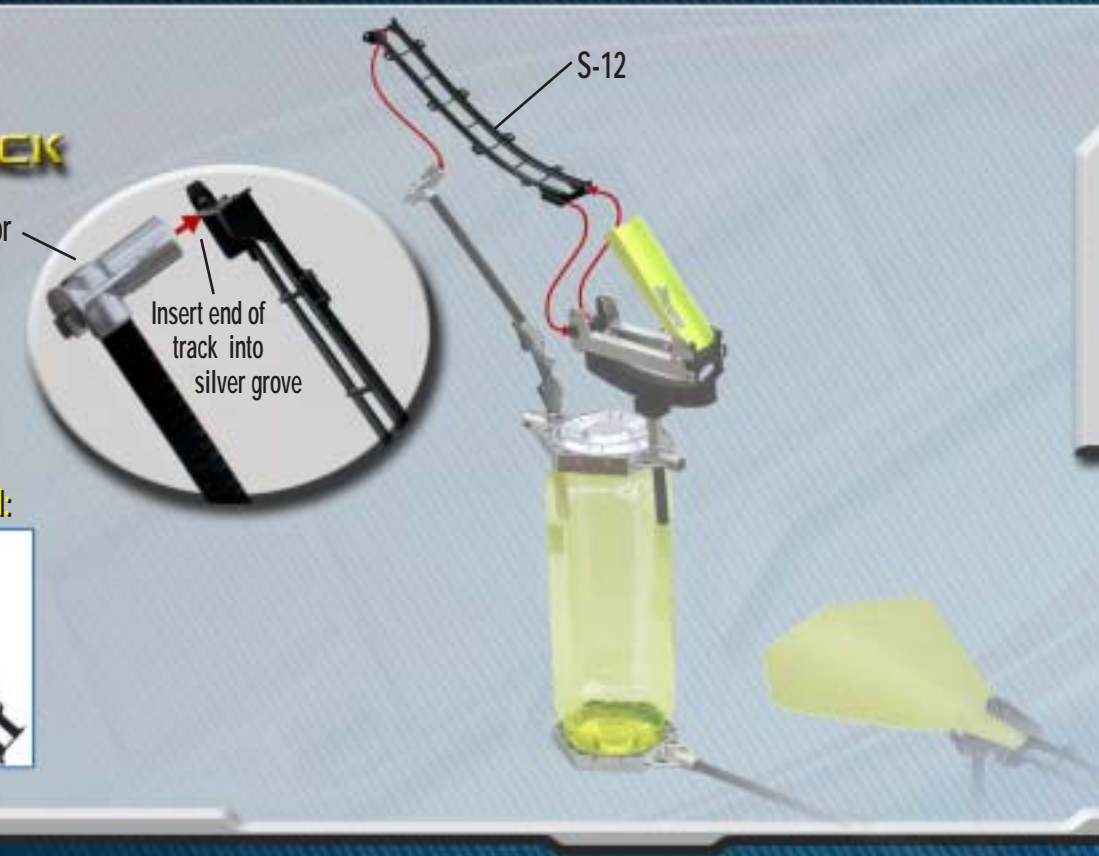

9

Add Clips

Parts required:

24 Clips



Upper Track Clip Locations

Lower Track Clip Locations

Landing Pad Clip Locations

10

ATTACH GUARDRAILS

Parts required:

11" (28 cm)

24" (61 cm)

11" (28 cm) Guardrail

24" (61 cm) Guardrail

Upper Track Guardrail Connections

11" (28 cm) Guardrail

24" (61 cm) Guardrail

Lower Track Guardrail Connections

FINISHED SET



Congratulations!
Your *TECH TRAX™* TRIGGER FLIP™ set is complete.
"You're a *TECH TRAX™* Master."
Now choose your *TECH TRAX™* car,
and you're ready to test your skill!

ALTERNATE LAYOUT

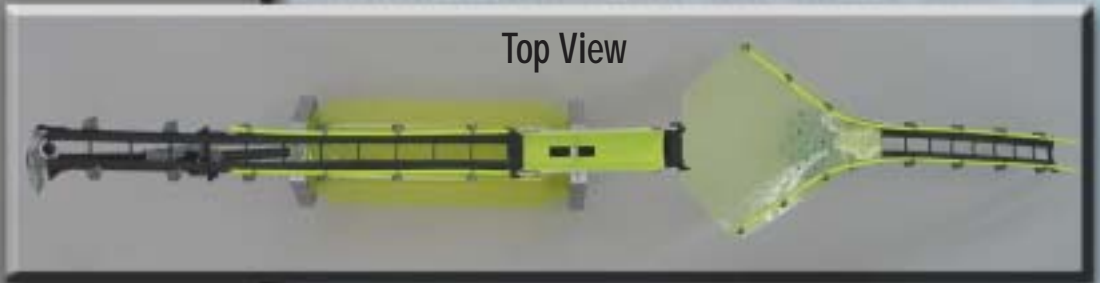
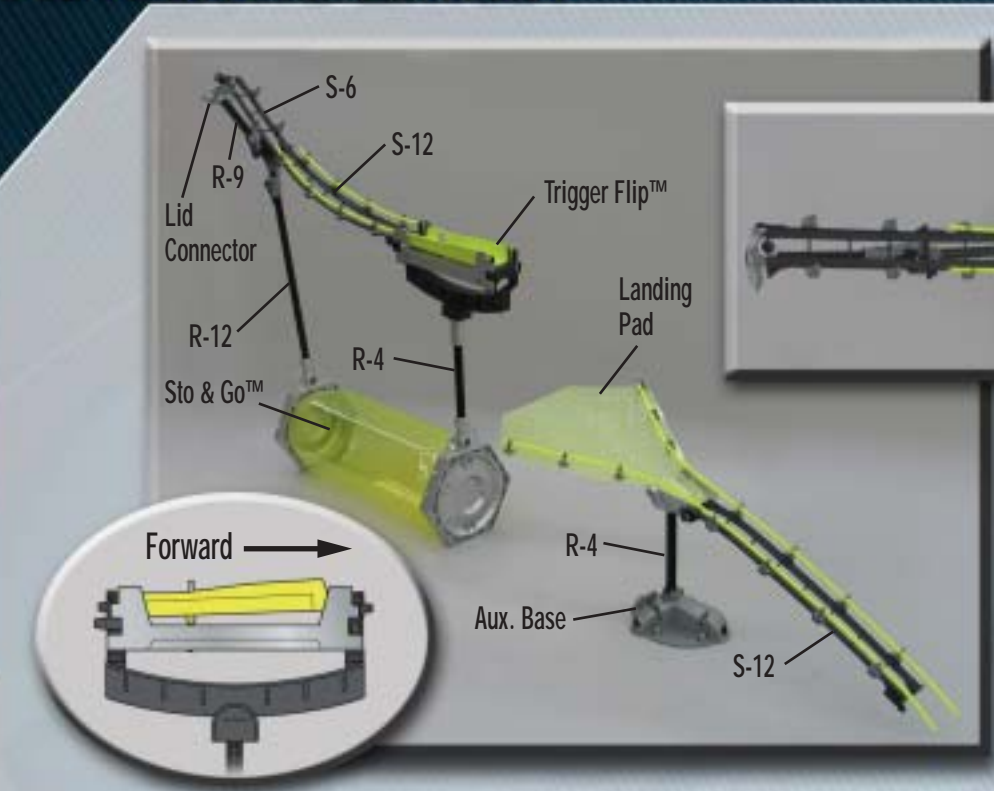

Now that you're a *TECH TRAX™* master
can you also build this set?

READY TO PLAY

1. Press Ramp Down To Lock Trigger.



2. Trigger Locked and Ready to Play.



Side View

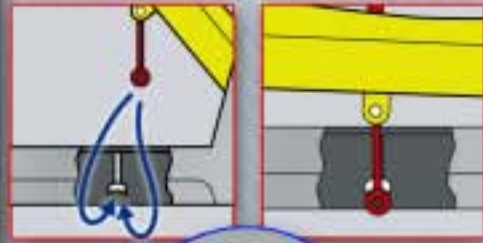

Top View



Use book as a tool to measure.

Adjust Distance

~15" (~38 cm)

HOW TO PLAY

Release Car Here

Vehicles not included.

Option Play-1

Car Hits Trigger, Launches Toward Landing Pad and Continues Down the Track.



Turn Jump Ramp

Option Play-2

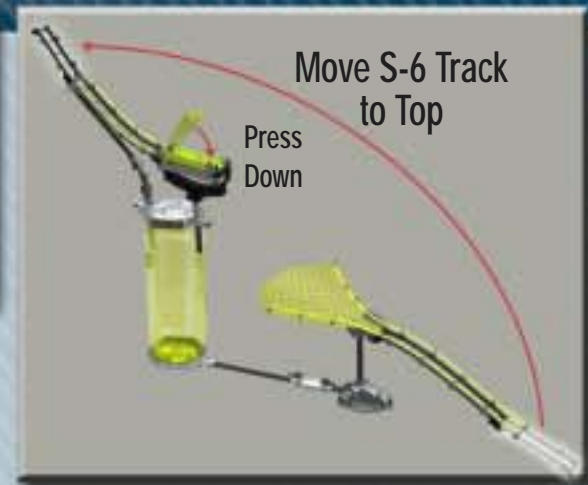

Move S-6 Track to Top

Press Down

Note: Jump ramp can be used in both directions to reverse flip



Release Car Here

FINISH!

AFTER PLAY TROUBLESHOOTING AND TIPS

STO & GO™!

All the pieces of your track set can be easily stored inside the unique STO & GO™ package!
Place larger items back in canister first:
Panel,
Trigger Flip™,
Aux. Base, etc.



Where Guardrail ends, be sure to carefully flex the ends outward, so that it won't impede the vehicles movement.



The T2P connector can be used as an adaptor for connecting the track pieces of TECH TRAX™, to existing Hot Wheels® track.



To use the 3XL, simply slide it onto one of the Rod pieces. (Note: Be sure the "Locking Key" is in the open position.)

Position along the rod where desired, and then turn the Lock key to secure.



To use the 45/90/T-Joints, simply slide a Rod into the open face of the joint, and then close over the cover element. (Note: Be sure the "Joint Key" is rotated into its "open" position.) To lock its position on the rod, rotate the Joint Key 90 degrees.

Fine tuning of the set is required to yield optimum performance.



By loosening the Locking Key, you can now set the angle of the track as you desire.



To remove the track from the Rotating Clip, simply squeeze its ends outward, and pull track out of the groove.



COLLECT AND CONNECT TECH TRAX™ SETS



G3736 Flex Loop™ Stunt Set

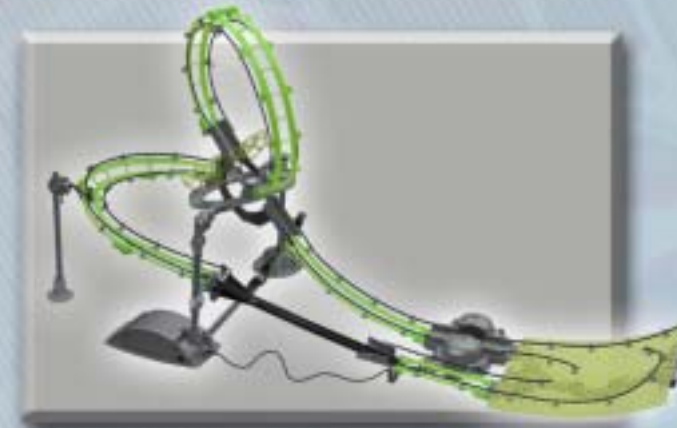

B6529 Crash Chamber™ Stunt Set

B4686 Power Swing™ Stunt Set

AVAILABLE CARS:



B4681 Jump Master™



B4682 Turbo Torque™



B4683 Power Pivot™

Each sold separately, subject to availability. Colors and decorations may vary.



THE ADVANCED CONSTRUCTION SYSTEM FOR ULTIMATE STUNTS

B4687-0900



8+



TRIGGER FLIP™ STUNT SET

- | | | |
|----------------------------|-------------------------|--------------------|
| (2) 11" (28 cm) Guardrails | (1) Landing Pad | (2) S-12 |
| (2) 24" (61 cm) Guardrails | (1) Landing Pad Support | (1) S-6 |
| (1) 45° Joint | (4) Lid Connector | (1) Sleeve |
| (1) Aux. Base | (2) R-6 | (1) STO & GO™ |
| (24) Clips | (1) R-9 | (1) T2P (not used) |
| (1) Coupler | (1) R-12 | |
| | (2) R-4 | |

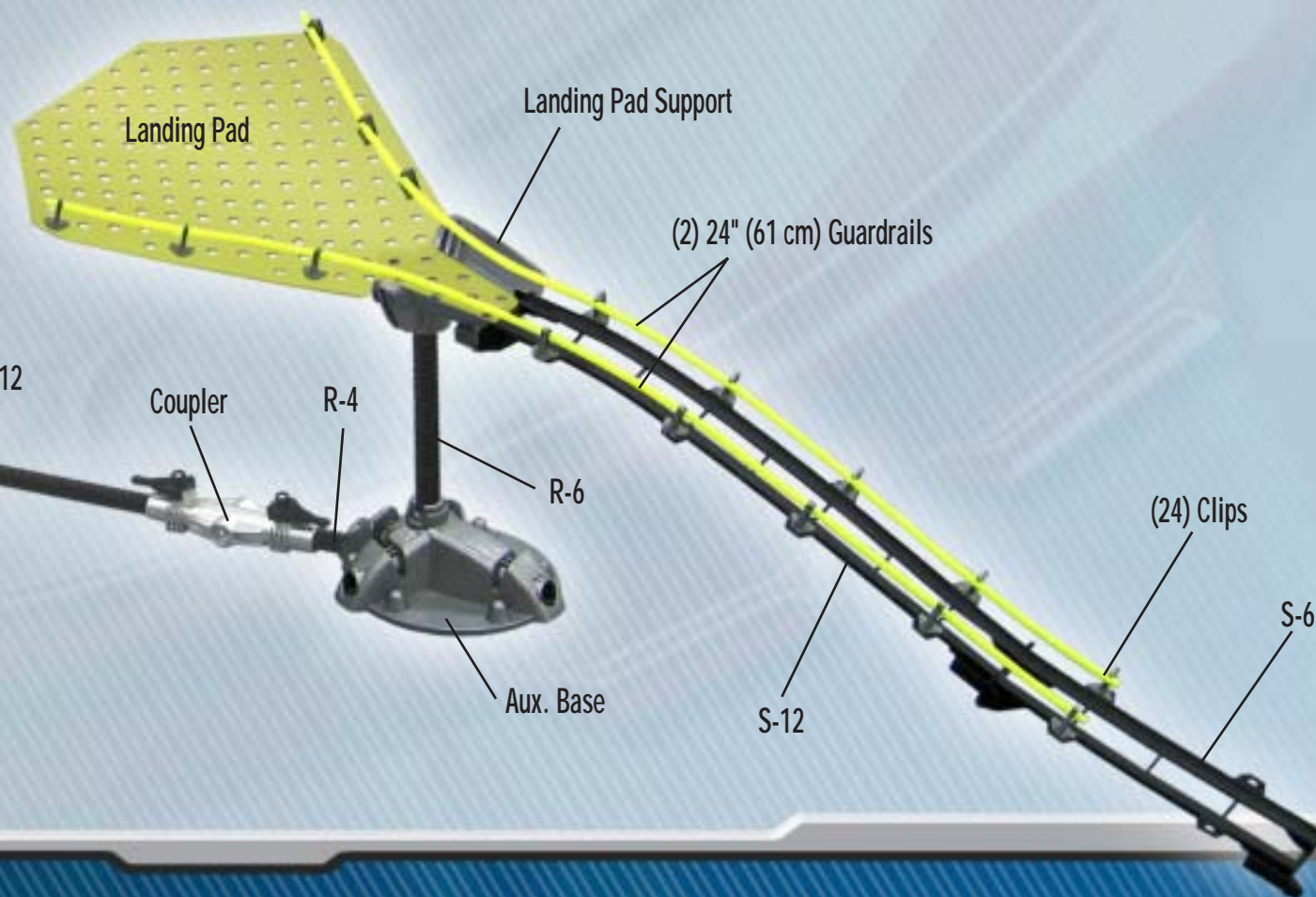

Vehicles not included.
Not for use with some Hot Wheels® Vehicles.

© 2004 Mattel, Inc. All Rights Reserved.

TECH TRAX™

THE ADVANCED CONSTRUCTION SYSTEM FOR ULTIMATE STUNTS



Cool cars, games and more!

• Mattel, Inc., El Segundo, CA 90245 U.S.A. Consumer Affairs 1 (800) 524-TOYS.
• Mattel U.K. Ltd., Vanwall Business Park, Maidenhead SL6 4UB. Helpline 01628500303.
• Mattel Australia Pty., Ltd., Richmond, Victoria. 3121. Consumer Advisory Service - 1300 135 312.

• Mattel East Asia Ltd., Room 1106, South Tower, World Finance Centre, Harbour City, Tsimshatsui, HK, China.
• Diimport & Diedarkan Oleh: Mattel SEA Ptd Ltd.(993532-P) Lot 13.5, 13th Floor, Menara Lien Hoe, Persiaran Tropicana Golf Country Resort, 47410 PJ. Tel:03-78803817, Fax:03-78803867.



TECH TRAX™

THE ADVANCED CONSTRUCTION SYSTEM FOR ULTIMATE STUNTS

FLEX LOOP™ STUNT SET



INSTRUCTIONS

8+

G3736-0920



© 2004 Mattel, Inc. All Rights Reserved.

PARTS

Twist off cap and empty contents

(1) STO & GO™

(2) Lid Connectors

(1) 45° Joint

(2) T-Joints

(2) 20" (50.8 cm) Guardrails

(2) 35" (89 cm) Guardrails

(2) Flex Loop™

(1) Loop Snap

(2) C-2

(38) Clips

(2) T2P (Adaptor for connecting to other tracks)

(1) R-15

(1) R-6

Launcher

(1) S-12

(2) S-6

(1) S-9

TECH TRAX™ BUILDING BASICS

Clips attach to tracks as shown. Notches on clips align with tabs on tracks to lock in proper position.

Press guardrails into clips until they snap and lock.

Track marking system.

Rod marking system.

All track connections lock together with the TECH TRAX™ system. Be sure tabs insert fully to lock tracks together properly as shown.

To unlock tracks, press in on locking tabs and pull apart at the same time as shown.

1 START ASSEMBLING

VERTICAL ROD LID CONNECTOR AND TOP LOOP SUPPORT

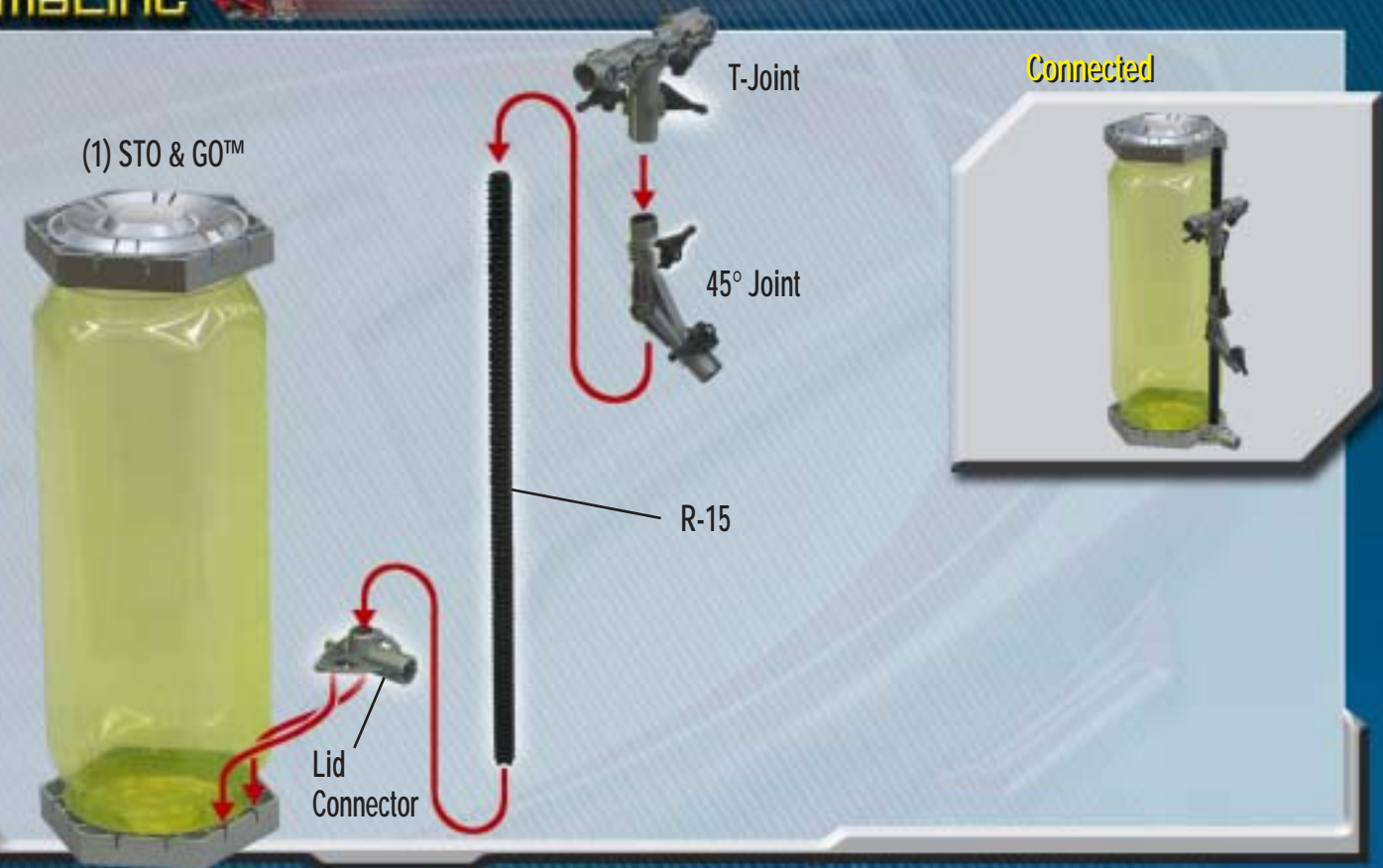

Parts required:



2

TOP LID CONNECTOR

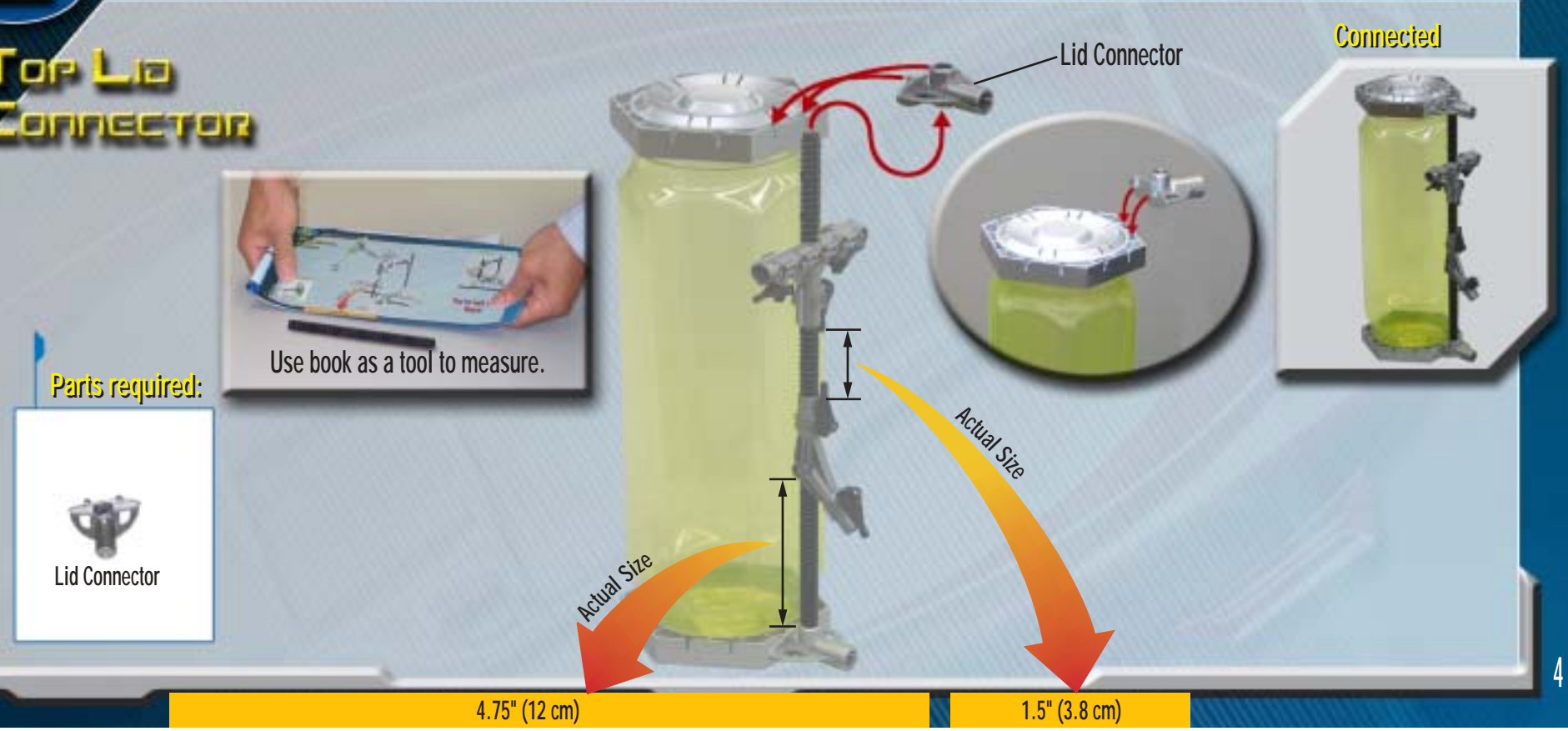

Parts required:

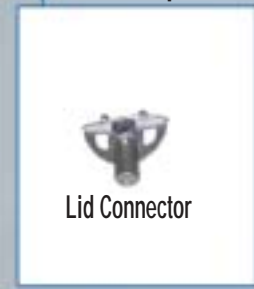

3

BOTTOM LOOP SUPPORT

Parts required:

T-Joint



R-6



Connected



5

4

FLEXIBLE LOOP

Parts required:



Flex Loop™



Snap on top and bottom.

Loop Support Connect Points

Connected



1" (2.5 cm)

6

5

Add Track Connectors

Parts required:



Connected



Snap on two T2Ps.

6

RIGHT SIDE TRACKS

Parts required:

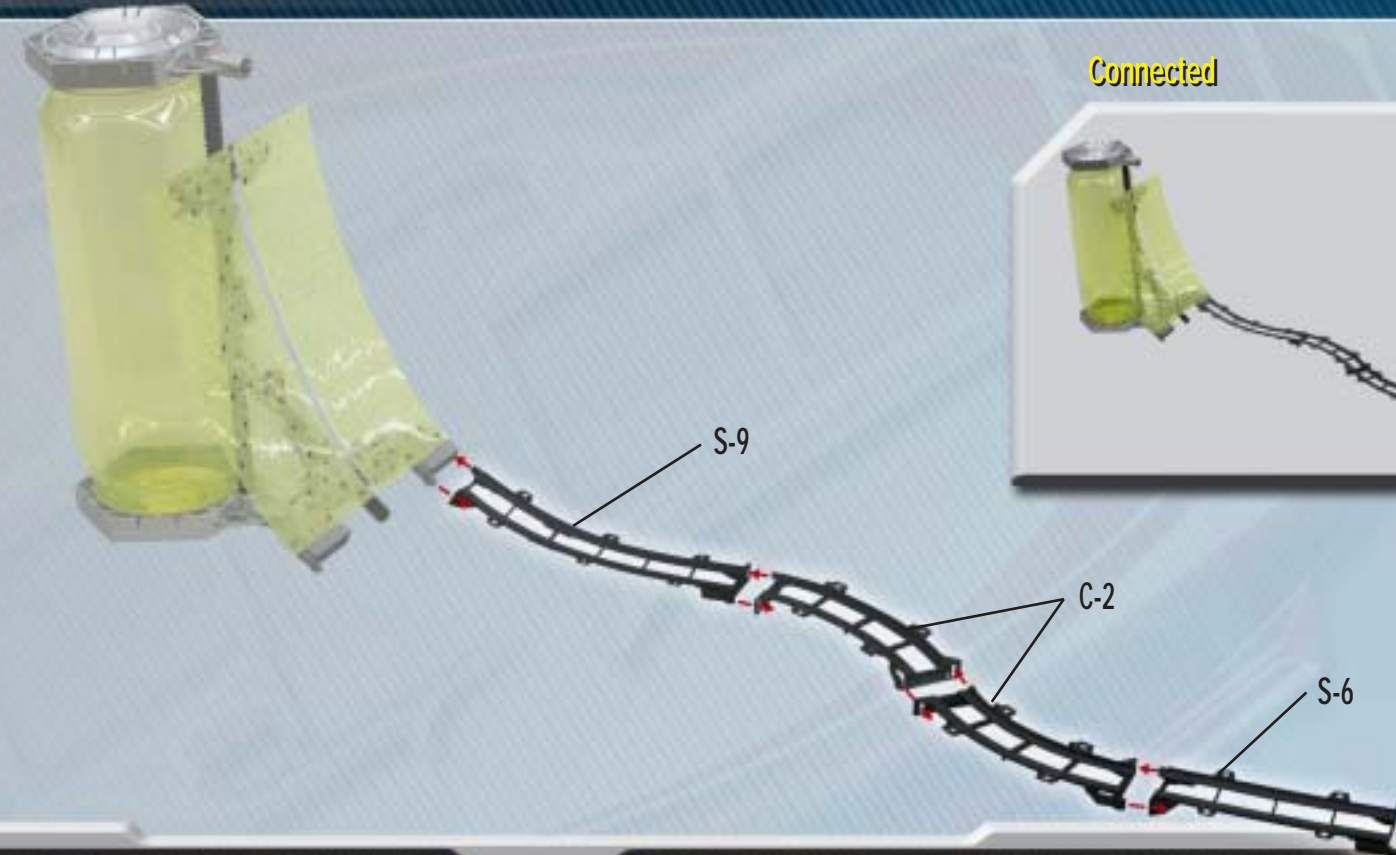
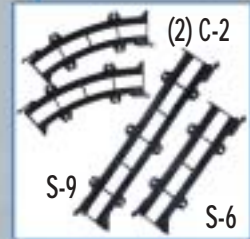

Connected



7

ADD LEFT SIDE TRACKS

Parts required:

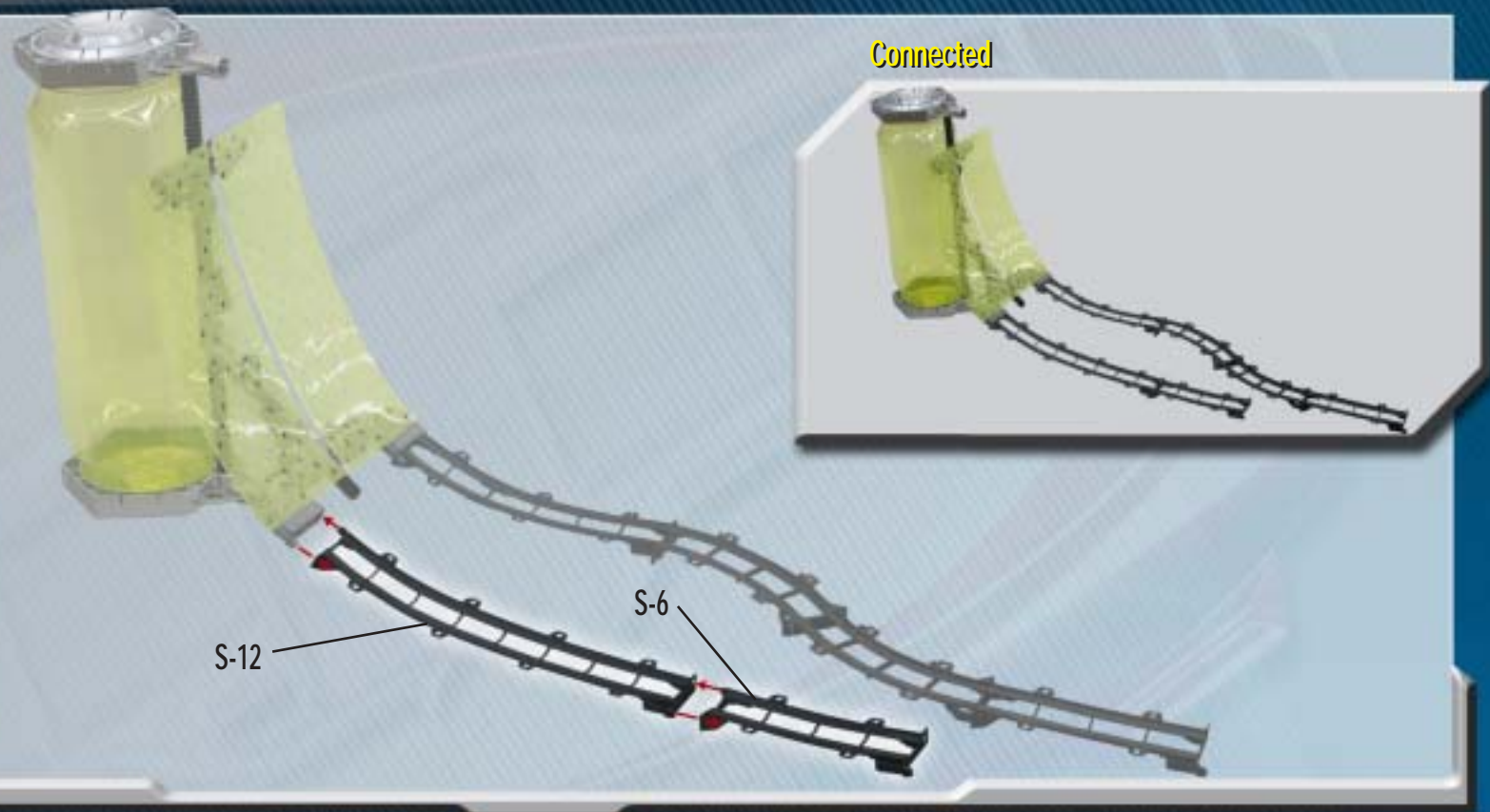

Connected

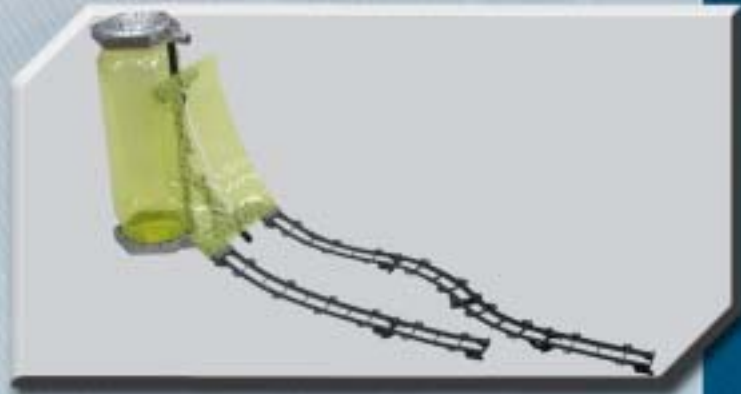

8

CONNECT LAUNCHER

Parts required:

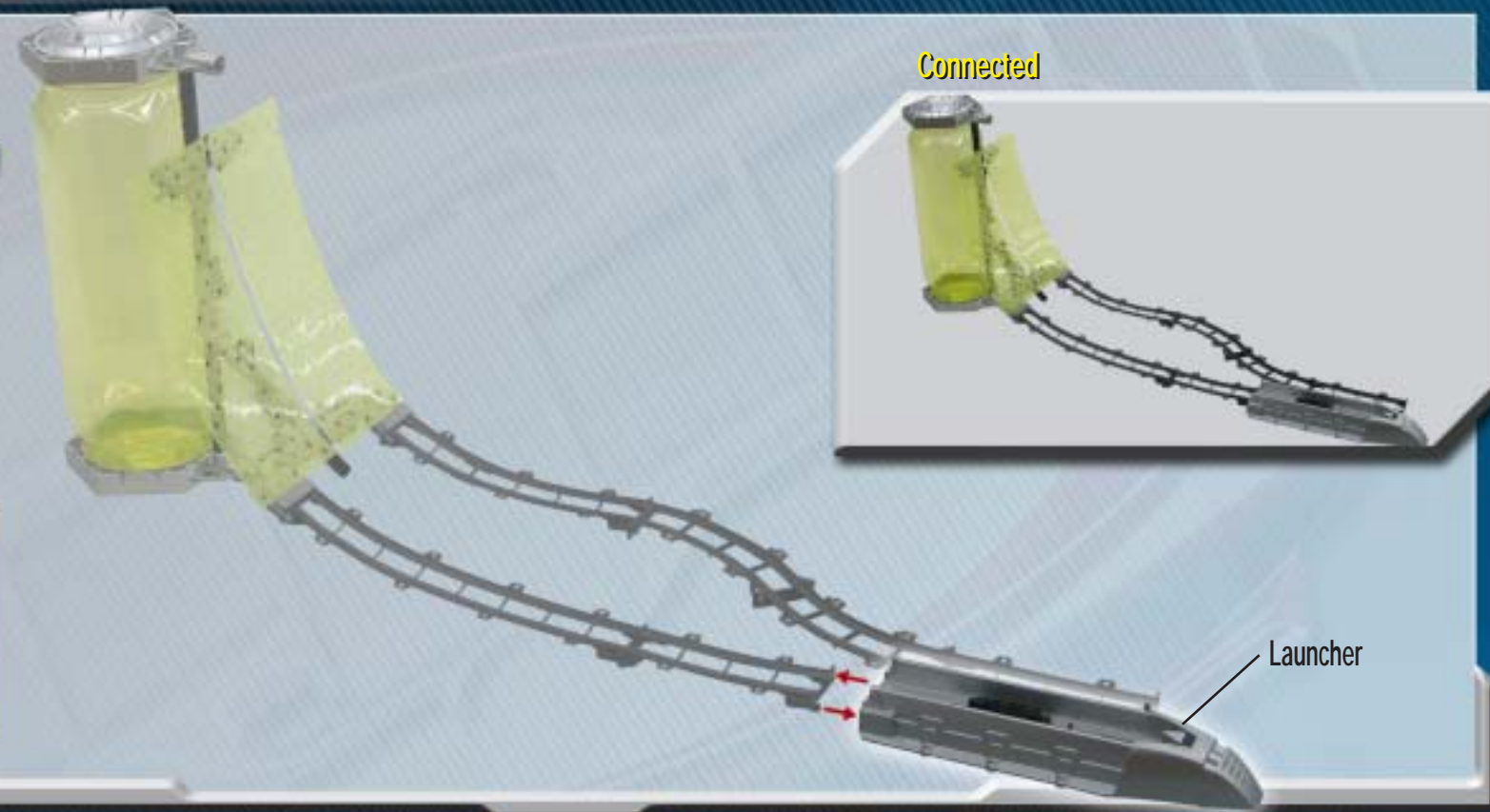

Connected

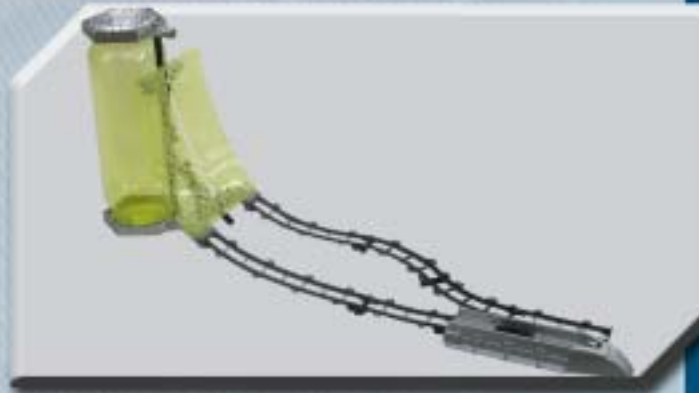

9

CLIPS

Parts required:

30 Clips

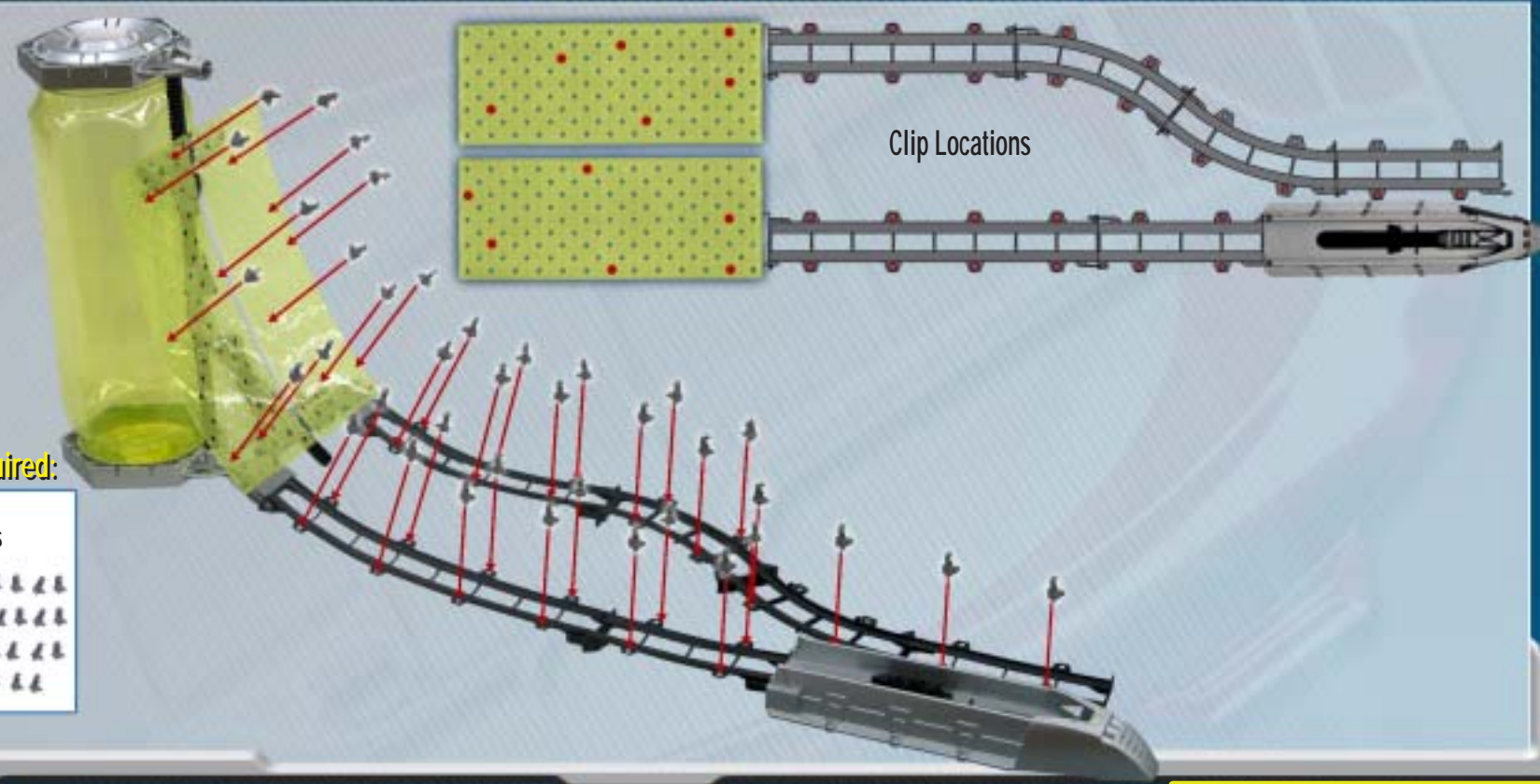

10

GUARDRAILS

Parts required:

- (2) 20" (50.8 cm)
- (2) 35" (89 cm)

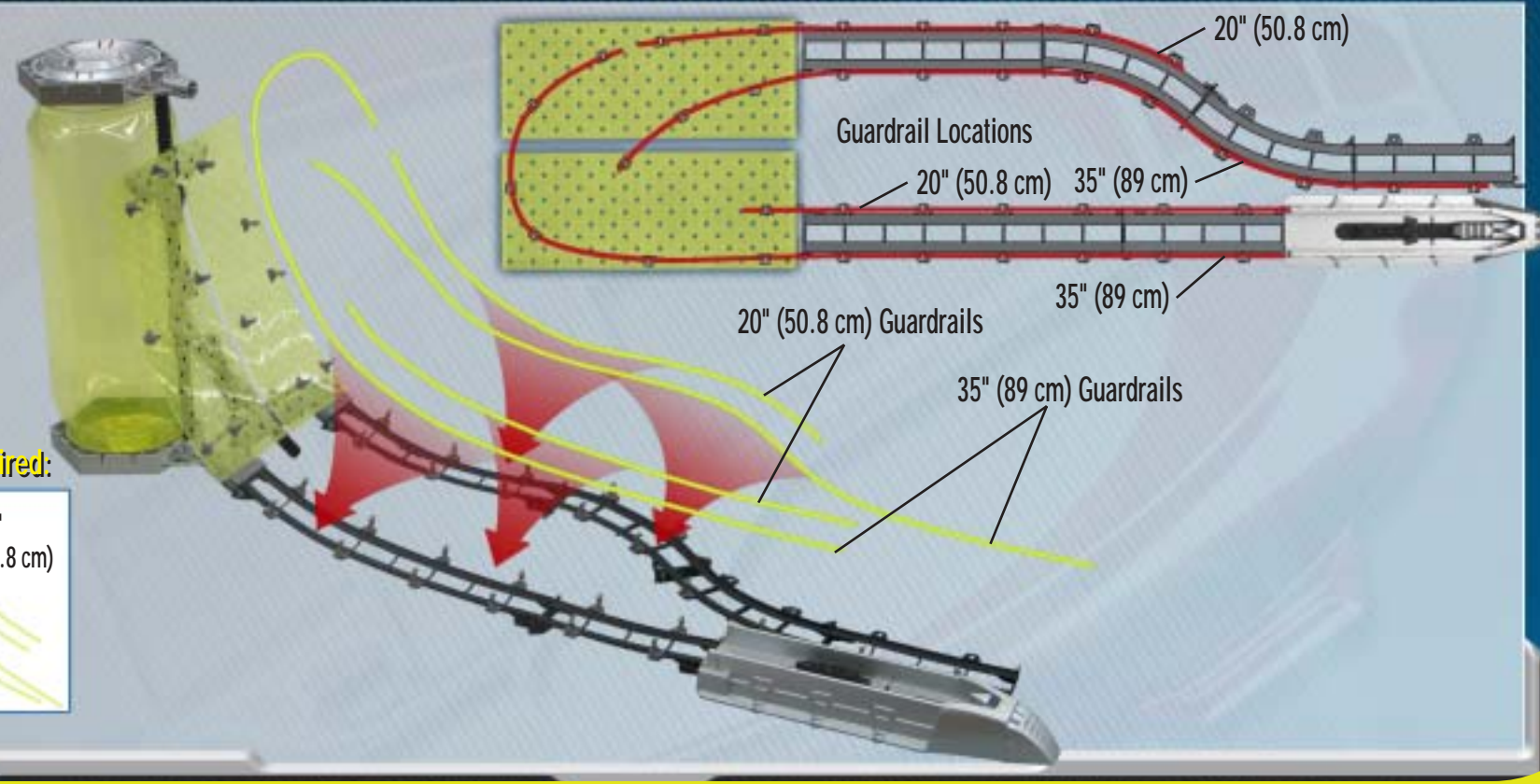

20" (50.8 cm) Guardrail

35" (89 cm) Guardrail

FINISHED SET



Congratulations!
Your **TECH TRAX™ FLEX LOOP™** set is complete.
"You're a TECH TRAX™ Master."
Now choose your car,
and you're ready to test your skill!

ALTERNATE LAYOUT

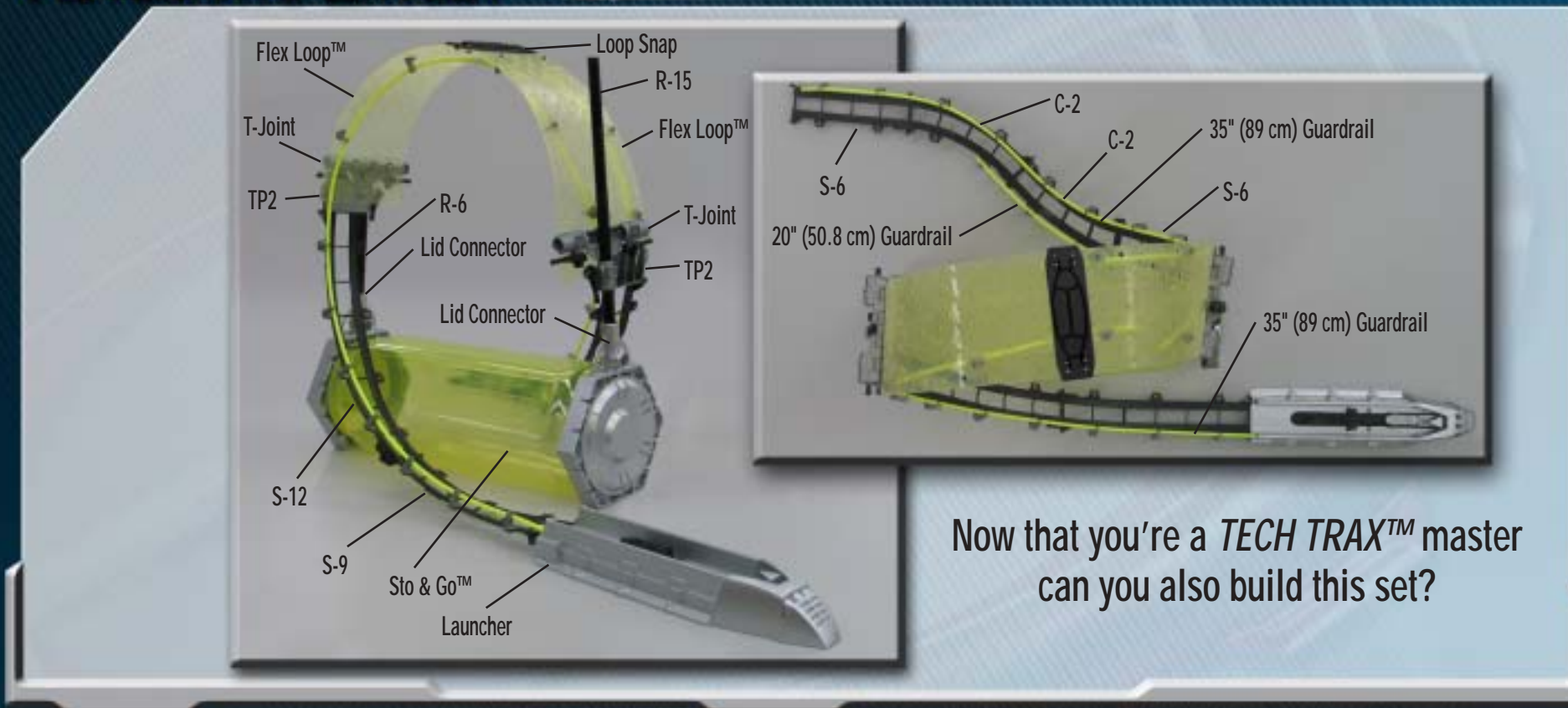

Now that you're a **TECH TRAX™** master
can you also build this set?

READY TO PLAY

HOW TO PLAY

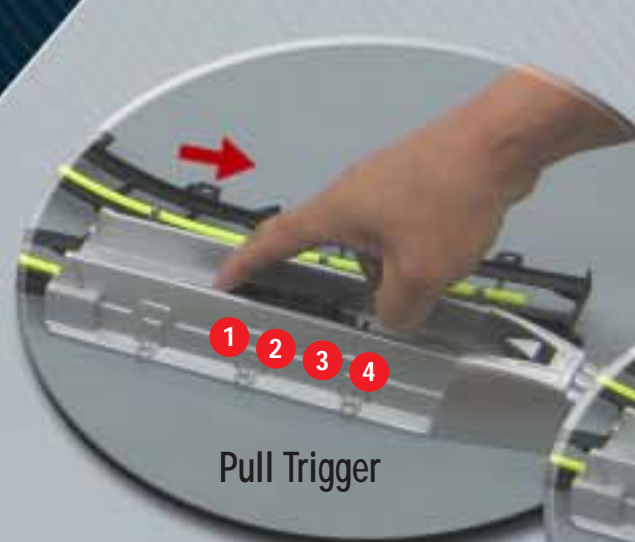

Pull Trigger



Place Car here



Vehicles not included.

Launcher has 4 speed levels, to vary the speed of your car around Flex Loop™.

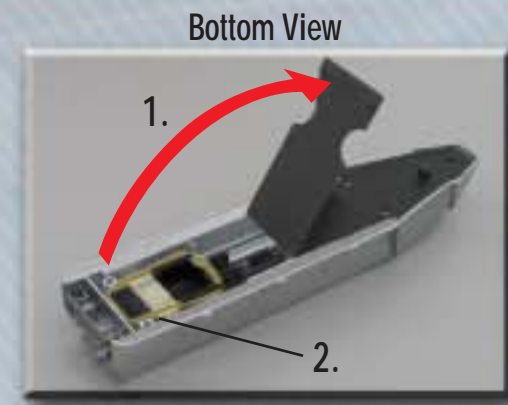

Bottom View

1.

2.

- 1. Pull back cover.
- 2. Replace rubber band.

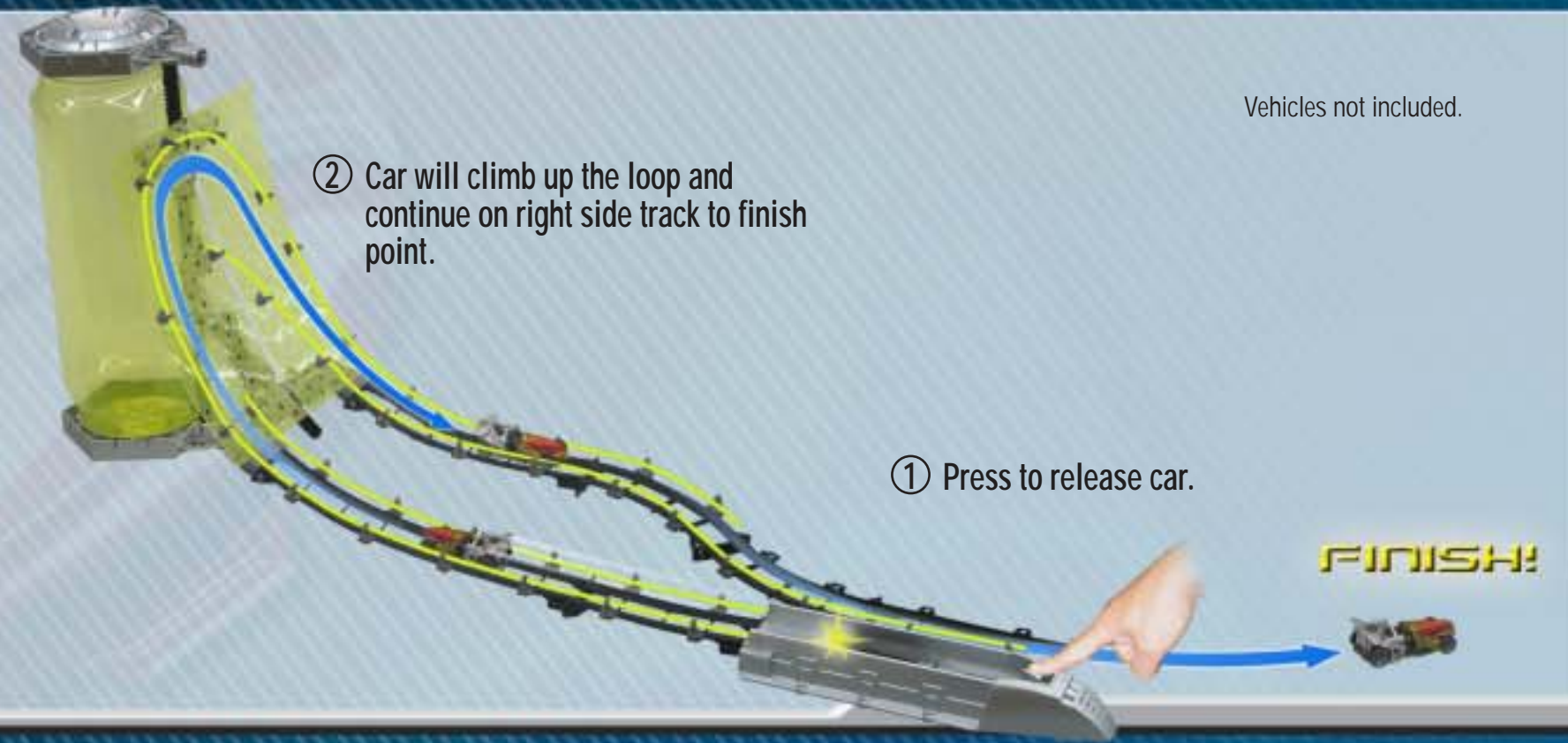

② Car will climb up the loop and continue on right side track to finish point.

① Press to release car.

Vehicles not included.

FINISH!

AFTER PLAY

TROUBLESHOOTING AND TIPS

STO & GO™!

All the pieces of your track set can be easily stored inside the unique STO & GO™ package!
Place larger items back in canister first.



Where Guardrail ends, be sure to carefully flex the ends outward, so that it won't impede the vehicles movement.

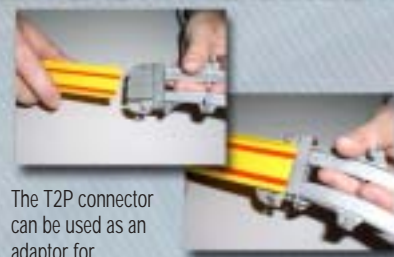

The T2P connector can be used as an adaptor for connecting the track pieces of **TECH TRAX™**, to existing Hot Wheels® track.



To use the 3XL, simply slide it onto one of the Rod pieces. (Note: Be sure the "Locking Key" is in the open position.)

Position along the rod where desired, and then turn the Lock key to secure.



To use the 45/90-T-Joints, simply slide a Rod into the open face of the joint, and then close over the cover element. (Note: Be sure the "Joint Key" is rotated into its "open" position.) To lock its position on the rod, rotate the Joint Key 90 degrees.

Fine tuning of the set is required to yield optimum performance.



To attach the track, take the section where two tracks are joined, and simply slide into the rotating clip unit.

By loosening the Locking Key, you can now set the angle of the track as you desire.



To remove the track from the Rotating Clip, simply squeeze its ends outward, and pull track out of the groove.

COLLECT AND CONNECT **TECH TRAX™** SETS



B4687 Trigger Flip™ Stunt Set

B4686 Power Swing™ Stunt Set



B6529 Crash Chamber™ Stunt Set

AVAILABLE CARS:



B4681 Jump Master™



B4682 Turbo Torque™



B4683 Power Pivot™

Each sold separately, subject to availability. Colors and decorations may vary.



TECH TRAX™

THE ADVANCED CONSTRUCTION SYSTEM FOR ULTIMATE STUNTS

G3736-0900



8+

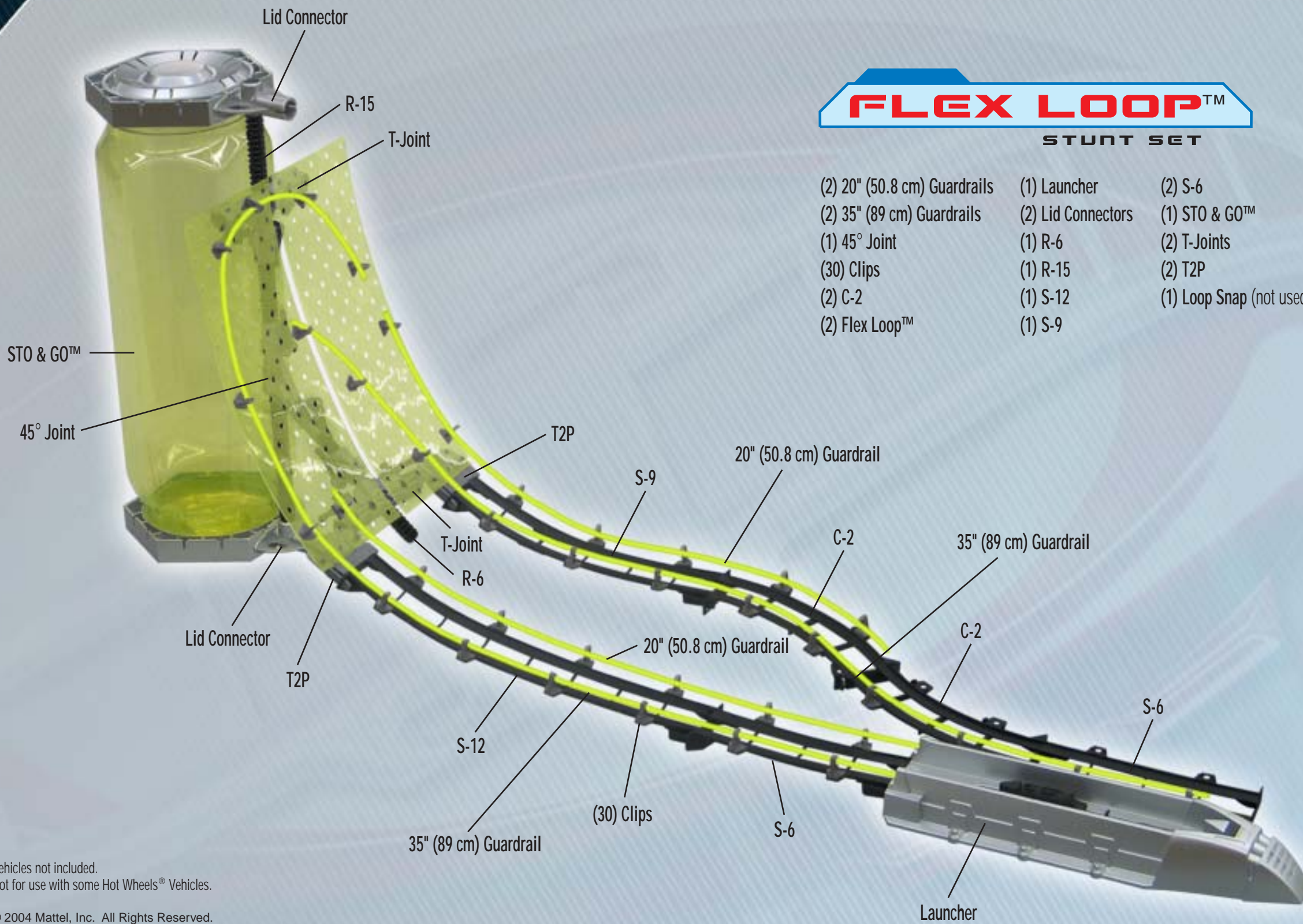

FLEX LOOP™ STUNT SET

- | | | |
|------------------------------|--------------------|--------------------------|
| (2) 20" (50.8 cm) Guardrails | (1) Launcher | (2) S-6 |
| (2) 35" (89 cm) Guardrails | (2) Lid Connectors | (1) STO & GO™ |
| (1) 45° Joint | (1) R-6 | (2) T-Joints |
| (30) Clips | (1) R-15 | (2) T2P |
| (2) C-2 | (1) S-12 | (1) Loop Snap (not used) |
| (2) Flex Loop™ | (1) S-9 | |

Vehicles not included.
Not for use with some Hot Wheels® Vehicles.

© 2004 Mattel, Inc. All Rights Reserved.