

Set one Super Charger across from the other for competition racing!

TRACK AND ACCESSORIES NEEDED FOR THIS LAYOUT

- | | |
|----------------------|--|
| (2) SUPER CHARGERS | (2) 3-inch (7.62 cm) SECTIONS OF HIGH WALL TRACK |
| (8) 45° CURVES | (8) CONNECTORS |
| (4) LEAD CURVE RIGHT | (12) 2-foot (61 cm) SECTIONS OF HIGH WALL TRACK |
| (4) LEAD CURVE LEFT | |

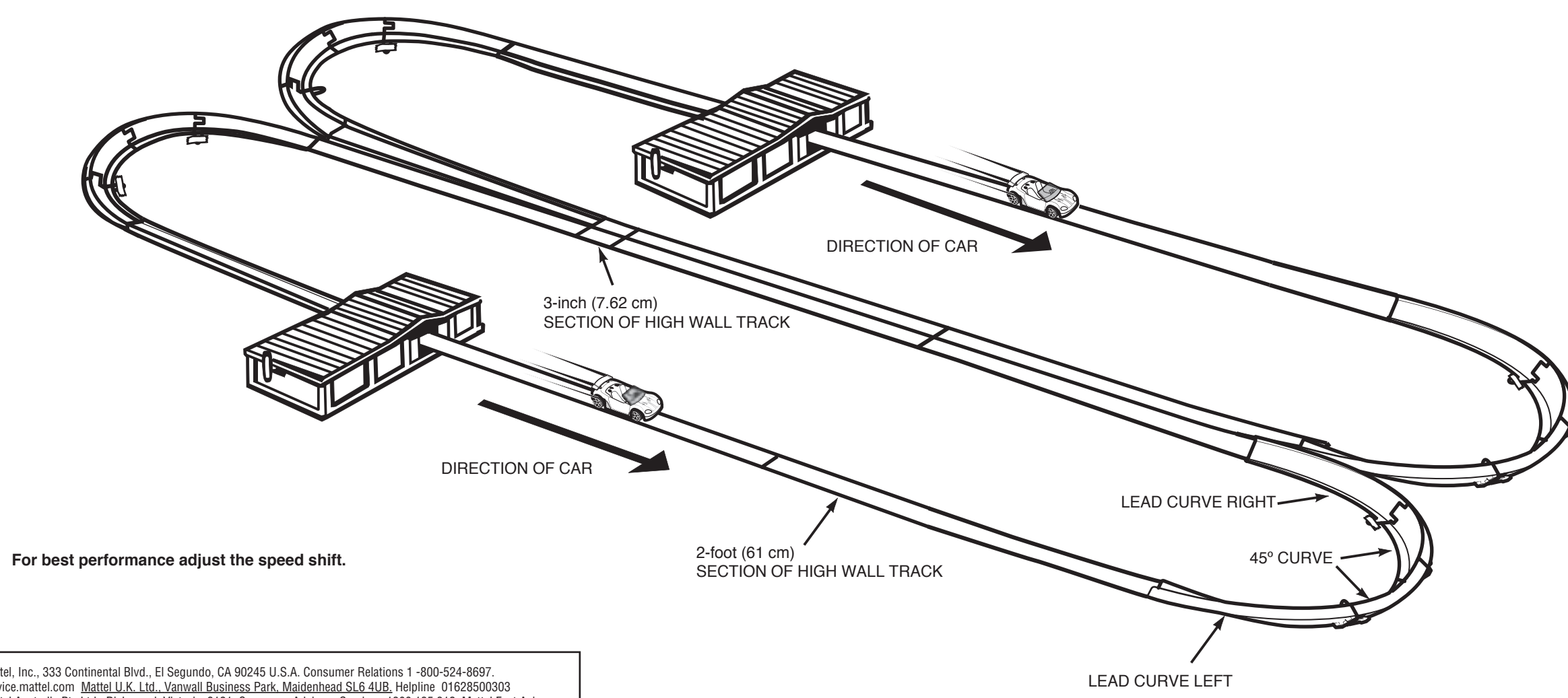

Mattel, Inc., 333 Continental Blvd., El Segundo, CA 90245 U.S.A. Consumer Relations 1-800-524-8697.
 service.mattel.com Mattel U.K. Ltd., Vauxhall Business Park, Maidenhead SL6 4UB, Helpline 01628900303
 Mattel Australia Pty Ltd., Richmond, Victoria 3121, Consumer Advisory Service - 1300 135 312, Mattel East Asia
 Ltd., Room 1106, South Tower, World Finance Centre, Harbour City, Tsimshatsui, HK, China, Dingrong & Dielakan
 Dist., Mattel SEA Ptd Ltd (99332-P) Lot 13.5, Menara Lien Hoe, Persiaran Tropicana Golf Country Resort, 47410 PJ,
 Tel 03-78803817, Fax 03-78803867.

INSTRUCTION SHEET SPECIFICATIONS	
SUPERCHARGER	
Toy No.:	H9605
Part No.:	0920
Trim Size:	17" W x 14" H
Folded Size:	8.5" W x 14" H
Type of Fold:	4 PANEL
# colors:	1
Colors:	Black
Paper Stock:	White Offset
Paper Weight:	70 lb.
EDM No.:	005

SPEED SHIFT CONTROL
 Move speed shift towards FAST to make car move faster.
 Move speed shift towards OFF to make cars move slower.

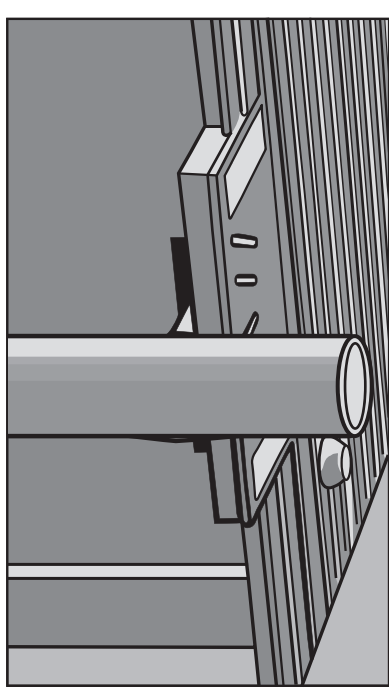

Turn track over and fit top of trestle in track and twist into track as shown.

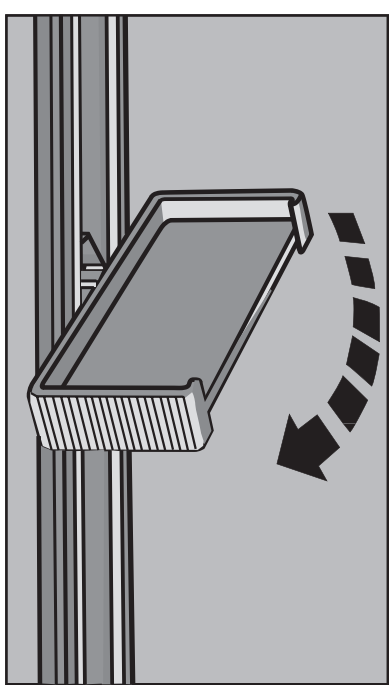

Attach track to Super Charger connector tabs as shown.

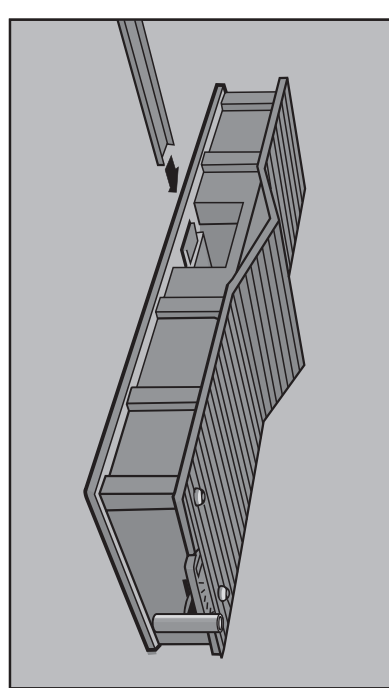

To start cars through Super Charger, set speed shift halfway between OFF and FAST. Gently push car through Super Charger to start it around the track.

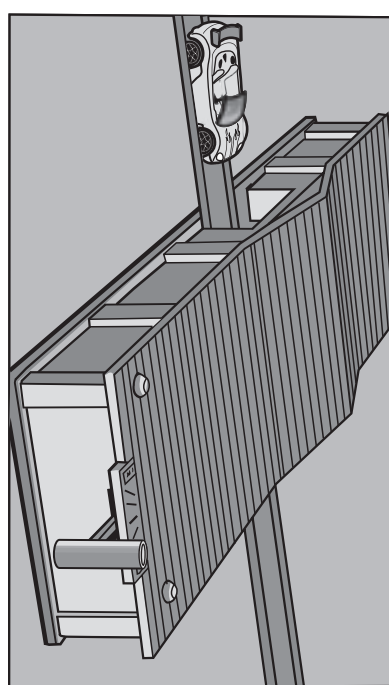

Turn Super Charger over. Uncover the battery cover with a Phillips-head screwdriver (not included). Insert 3 "D" (LR20) batteries in the orientation shown. Replace the battery door and tighten screw. For longer life use only alkaline batteries. Requires 3 "D" (LR20) batteries, not included.

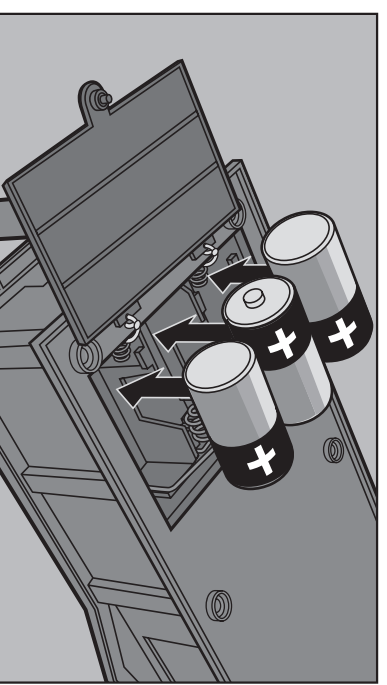

CONTENTS

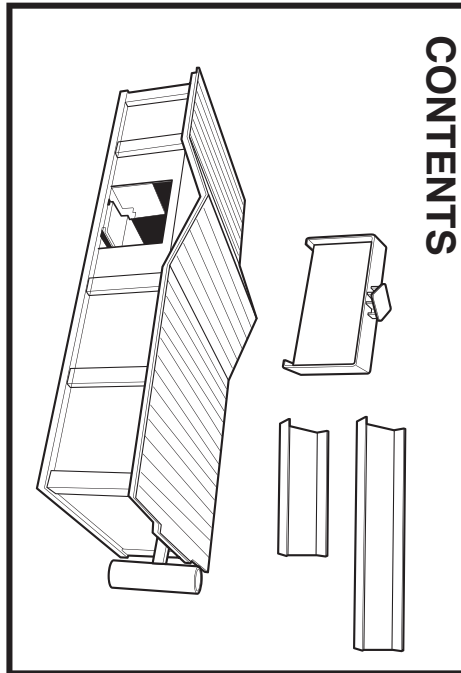

GET READY TO PLAY

If a car is stuck inside the Super Charger, turn motor off. Gently pull car out. NEVER PUT YOUR FINGERS INSIDE THE SUPER CHARGER WHILE THE MOTOR IS RUNNING! Follow these simple rules for hours of safe HOT WHEELS® racing fun!

CURIOUS ABOUT YOUR SUPER CHARGER?

Good. It has an interesting, powerful boosting mechanism. But play it safe! If you want to look inside the Super Charger, be sure to turn the motor off first. NEVER LOOK INSIDE THE SUPER CHARGER WHEN THE MOTOR IS RUNNING!

SAFE DRIVING RULES

Keep these instructions for future reference as they contain important information.



Set up an exciting oval speedway with one Super Charger

TRACK AND ACCESSORIES NEEDED FOR THIS LAYOUT

- | | |
|---|----------------------|
| (1) SUPER CHARGER | (6) CONNECTORS |
| (1) TRESTLE | (4) 45° CURVES |
| (8) 2-foot (61 cm) SECTIONS OF HIGH WALL TRACK | (2) LEAD CURVE RIGHT |
| (1) 3-inch (7.62 cm) SECTION OF HIGH WALL TRACK | (2) LEAD CURVE LEFT |

TUNE-UP TIPS FOR TOP-SPEED PERFORMANCE!

- KEEP WHEELS AND AXLES IN PROPER ALIGNMENT. Like all fine race cars, Hot Wheels® cars race faster and farther when wheels and axles are straight. The special thin racing axles may need periodic adjustment. If so, carefully bend wheels back into position-do not pull out.
- DO NOT OIL WHEELS AND AXLES! Ordinary oils will harm wheels.

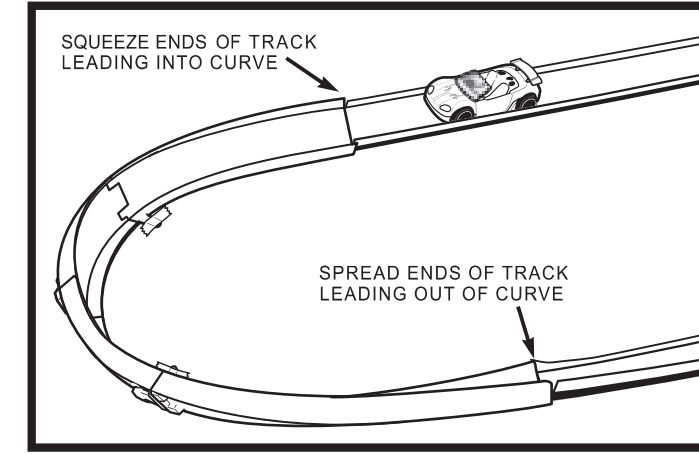
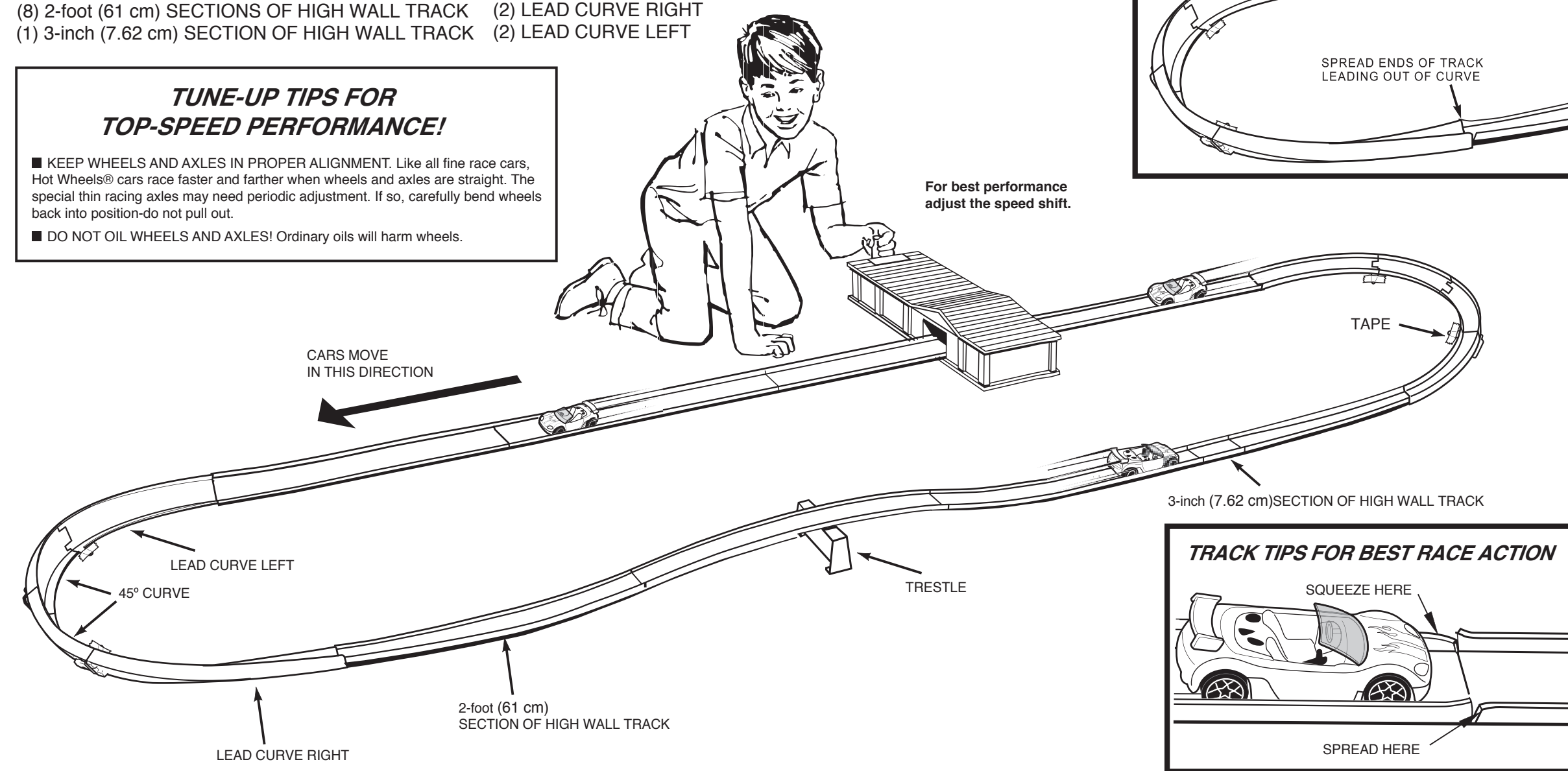

TRACK TIPS FOR BEST RACE ACTION

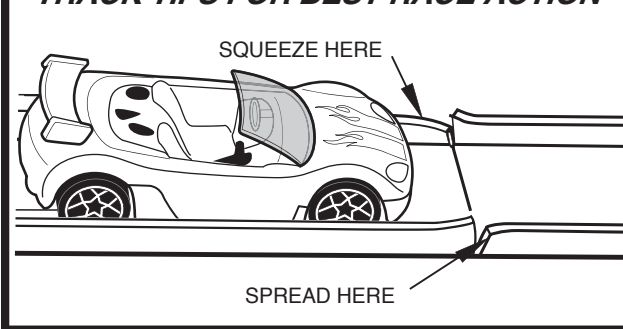

On waxed or very smooth floors you may improve Hot Wheels® track performance by taping the curves in place.

Stack one SUPER CHARGER on another for thrilling over and under racing.

TRACK AND ACCESSORIES NEEDED FOR THIS LAYOUT

- | |
|--|
| (2) SUPER CHARGERS |
| (12) 2-foot (61 cm) SECTIONS OF HIGH WALL TRACK |
| (2) 3-inch (7.62 cm) SECTIONS OF HIGH WALL TRACK |
| (1) 6-inch (15.2 cm) SECTION OF HIGH WALL TRACK |
| (12) CONNECTORS |
| (4) 45° CURVES |
| (3) LEAD CURVE RIGHT |
| (3) LEAD CURVE LEFT |
| (3) TRESTLES |
| (1) FLAT HALF CURVE |
| (1) 1-foot (30.5 cm) SECTION OF HIGH WALL TRACK |

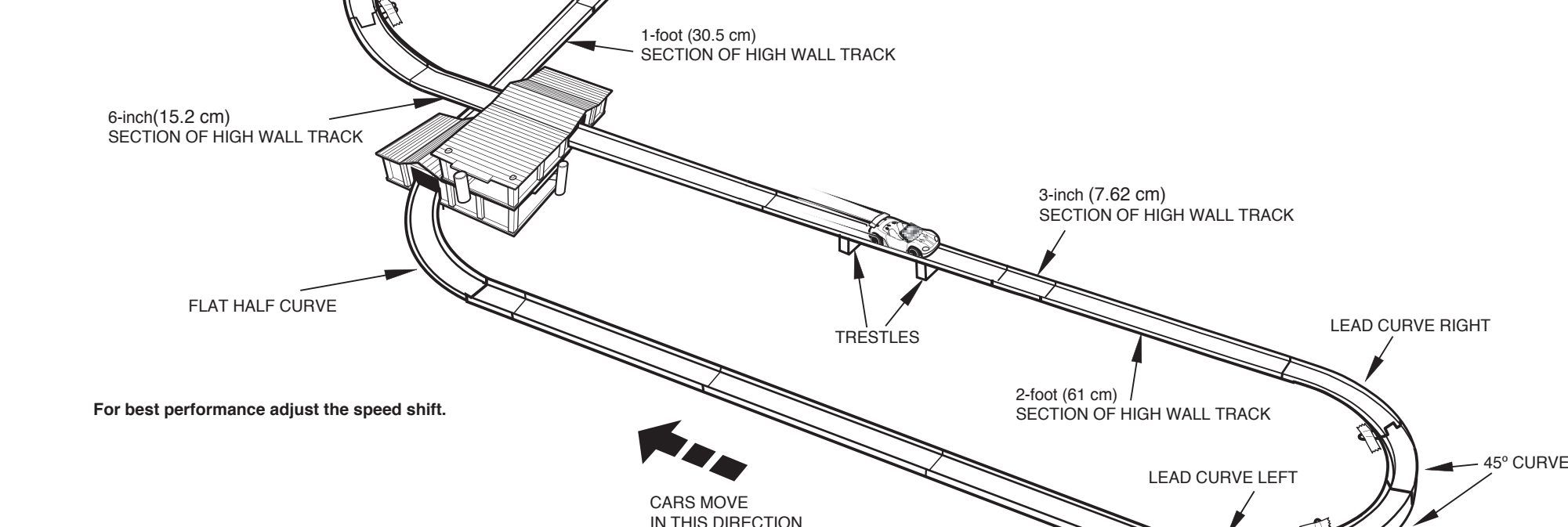

TO STACK SUPER CHARGER

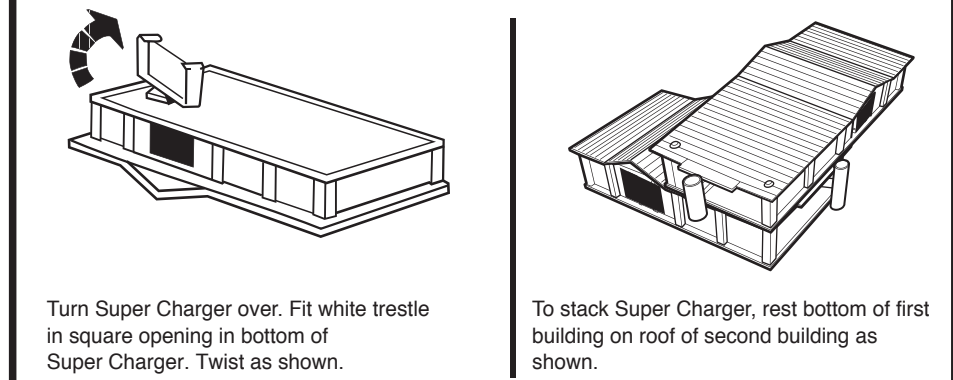

Protect the environment by not disposing of this product with household waste (2002/96/EC). Check your local authority for recycling advice and facilities.

Battery Safety Information
 In exceptional circumstances batteries may leak fluids that can cause a chemical burn injury or ruin your product. To avoid battery leakage:
 • Non-rechargeable batteries are not to be recharged.
 • Rechargeable batteries are to be removed from the product before being charged (if designed to be removable).
 • Rechargeable batteries are only to be charged under adult supervision (if designed to be removable).
 • Do not mix alkaline, standard (carbon-zinc), or rechargeable (nickel-cadmium) batteries.
 • Do not mix old and new batteries.
 • Only batteries of the same or equivalent type as recommended are to be used.
 • Batteries are to be inserted with the correct polarity.
 • Exhausted batteries are to be removed from the product.
 • The supply terminals are not to be short-circuited.
 • Dispose of battery(ies) safely.
 • Do not dispose of this product in a fire. The batteries inside may explode or leak.