

Ages 7 and Up
2 to 10 Players

How to Play

UNO Attack!™ Game

**It's a Random, Rapid-Fire
Card Shoot-Out!**



CONTENTS

112 cards as follows:

18 Blue cards - 1 to 9

18 Green cards - 1 to 9

18 Red cards - 1 to 9

18 Yellow cards - 1 to 9

8 Hit 2 cards - 2 each in blue, green, red and yellow

8 Reverse cards - 2 each in blue, green, red and yellow

8 Skip cards - 2 each in blue, green, red and yellow

4 Discard All cards - 1 each in blue, green, red and yellow

4 Trade Hands cards - 1 each in blue, green, red and yellow

4 Wild cards

2 Wild All-Hit cards

2 Wild Hit-Fire cards

Card Launcher Top

Card Launcher Bottom

NOTE: Only use projectiles supplied with this toy.

ADULTS NOTE: If cards are slipping on the rubber roller and do not come out, clean the rubber roller with a damp cloth or a cloth dipped in rubbing alcohol.

Please remove all components from package and compare them to the component list. If any items are missing, please call 1-800-524-TOYS.

Keep these instructions for future reference as they contain important information.

HOW TO REPLACE BATTERIES

UNO ATTACK! requires 3 C size Alkaline Batteries (not included). Use only Alkaline Batteries. Toy may not function with other types of batteries.

1. Unscrew battery compartment cover with a Phillips screwdriver (not included) and lift open.
2. Install 3 C size Alkaline Batteries in compartment as shown. (See Figure 1.)
3. Replace cover by slipping tabs into place, pressing cover down and screwing shut.

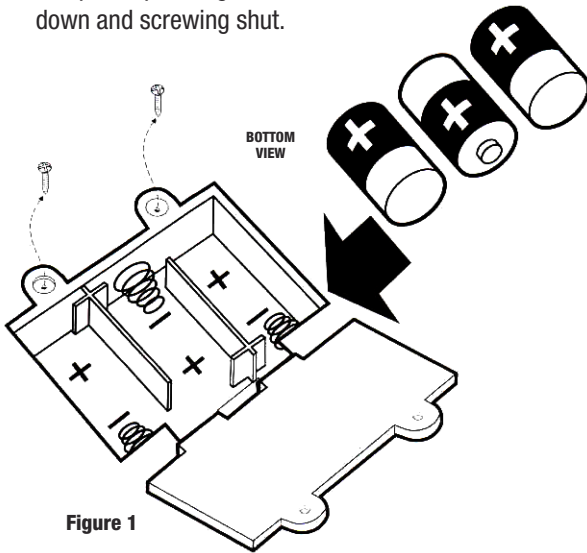

BATTERY SAFETY INFORMATION

- Non-rechargeable batteries are not to be recharged.
- Rechargeable batteries are to be removed from the toy before being charged.
- Rechargeable batteries are only to be charged under adult supervision (if designed to be removable).
- Rechargeable batteries are only to be recharged under adult supervision.
- Do not mix alkaline, standard (carbon-zinc), or rechargeable (nickel-cadmium) batteries.
- Never mix old batteries with new batteries (replace all batteries at the same time).
- Only batteries of the same or equivalent type as recommended are to be used.
- Dispose of batteries safely.
- Do not dispose of in a fire as batteries may explode or leak.
- Batteries are to be inserted with the correct polarity.

SETUP

1. Remove Bottom and Top Halves of Launcher from package.
2. Connect Launcher Halves by pushing Red UNO Top into Purple Base at an angle until it “clicks” into place. (See Figure 2.)

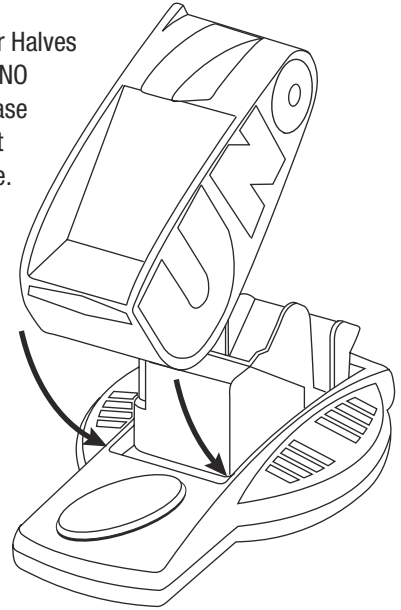

3. Push back of Red UNO Top down to close. (See Figure 3.)

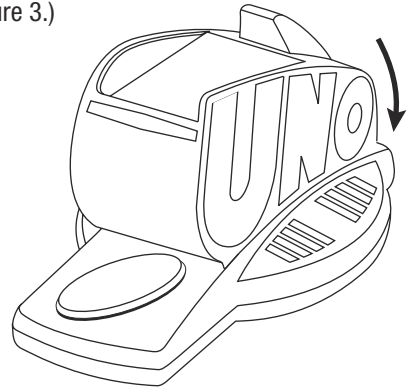

OBJECT

Be the first player to score 500 points. The first player to get rid of all the cards in their hand scores points for the cards left in their opponents' hands.

UNO ATTACK IN A NUTSHELL

Each player is dealt 7 cards. Place one card from the deck on top of the Launcher to begin a DISCARD pile. Open the Launcher, insert the remaining cards facedown inside, then close. (See Figure 4.)

IMPORTANT: During play, rotate the Launcher so it always faces the player whose turn it is.

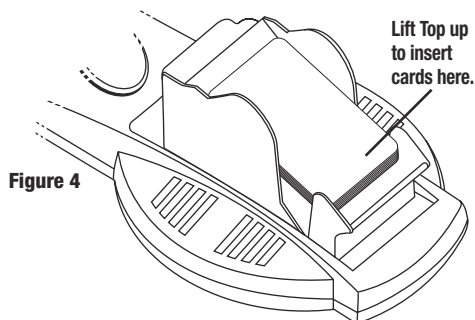

The first player has to match the card in the DISCARD pile either by number, color or word. For example, if the card is a red 7, you must throw down a red card or any color 7 onto the DISCARD pile. Or, you can throw down a Special Card, if appropriate (see Special Cards section). If you don't have anything that matches, you must hit the Launcher button. **If nothing happens, play moves to the next person.** If cards shoot out, you must add these cards to your hand. Then play passes to the left (until a Reverse card is played – see Special Cards section).

NOTE: If any cards are left sticking out of the Launcher after activation, the player who caused the Launcher to activate must take these cards and add them to his/her hand.

When you have one card left, you must yell UNO (meaning one) before playing your next to last card. Failure to do this results in your having to hit the Launcher button TWICE. (That is, of course, if you get caught by the other players.)

Once a player is out of cards, the hand is over. Points are totaled (see Scoring section) and you start over again. That's UNO Attack! in a nutshell.

Replace batteries when Card Launcher slows down.

NOW FOR THE DETAILS

CHOOSING A DEALER

Every player picks a card. The person who picks the highest

number deals. If you picked a Special Card, too bad – they don't count. The dealer deals 7 cards to each player, starts the Discard pile (see Starting the Discard Pile section), then loads the Launcher. Player to the left of dealer starts play.

STARTING THE DISCARD PILE

If a word card is the first one turned up to form the DRAW pile, this is what happens:



Reverse Card - The dealer plays first, but play then goes to the right instead of left.



Skip Card - The player to left of the dealer doesn't start (is skipped). The player to left of the skipped player starts.



Wild Card - The player to the left of the dealer calls out a color, then plays.



Hit 2 - The player to the left of the dealer must hit the Launcher button twice. Then play begins with the next player (the second player to the dealer's left).



Trade Hands - It's put back in the deck and another one is chosen.



Discard All - The player to the left of the dealer begins play with a card of the same color, or another Discard All card. If that's not possible, he/she must hit the Launcher button.



Wild All Hit - Each player (beginning with the person to the dealer's left) must press the Launcher button once. If the Launcher doesn't shoot out any cards, play continues with the player to the left. Any cards that shoot out must be added to the player's hand(s) who activated the Launcher. (NOTE: More than one player may activate the Launcher. The dealer does not activate the Launcher.) Play continues as normal.



Wild Hit-Fire - Only the player to the dealer's left presses the Launcher button until the Launcher fires. The activating player adds the Launched cards to his/her hand, then play begins with the next player to his/her left.

SPECIAL CARDS

Reverse - Simply reverse direction of play. Play left becomes play right, and vice versa.

Skip - The next player to play loses his/her turn and is "skipped."

Wild Card - This card can be played on any card. The person playing the card calls any color to continue play, including the one presently being played if desired. A Wild card can be played even if the player has another playable card in his/her hand.

Hit 2 - When this card is played, the next player must hit the Launcher button twice. His/her turn is then over; play continues with the next player.

Trade Hands - When this card is played, the player discarding the Trade Hands card **MUST** trade his/her hand with another player of his/her choosing.

Discard All - Play this card when you want to discard all of the cards in your hand of the same color. For example, if a yellow "7" is in the Discard pile, you may discard all the yellow cards in your hand, with a yellow Discard All card placed on top. (You may also discard a Discard All card on top of another Discard All card.)

Wild All Hit - When this card is played the player calls a color, then each player (beginning with the person to the

discard player's left) must press the Launcher button once. If the Launcher doesn't shoot out any cards, play continues with the player to the left. Any cards that shoot out must be added to the player's hand(s) who activated the Launcher. (NOTE: More than one player may activate the Launcher. The player who played the Wild All Hit card does not press the Launcher button.) Then play continues as normal.

Wild Hit-Fire - When this card is played the player calls a color, then the next player in the direction of play must press the Launcher button until the Launcher shoots out cards. The activating player adds the Launched cards to his/her hand and forfeits his/her turn, then play continues as normal with the next player.

GOING OUT

When you have one card left, you must yell UNO (meaning one) before playing your next to last card. Failure to do this results in your having to hit the Launcher button **TWICE**. (That is, of course, if you get caught by the other players.)

If you forget to say UNO before your card touches the Discard pile, but you "catch" yourself before another player catches you, you are safe and not subject to the penalty.

You may not catch a player for failure to say UNO until their second-to-last card touches the Discard pile. Also, you may not catch a player for failure to say UNO after the next player begins their turn. "Beginning a turn" is defined as either playing a card or hitting the Launcher button.

If a player goes out by discarding a Wild All Hit card or Wild Hit-Fire card, all players must follow the normal rules for these cards. A player may not go out on a Trade Hands card.

Once the Discard pile reaches the same level as the top of the plastic "stopper" that holds the pile in place, reshuffle the Discard pile, reload the Launcher and continue play.

SPECIAL RULES

If any cards are left sticking out of the Launcher

after activation, the player who caused the Launcher to activate must take these cards and add them to his/her hand.

SCORING

When you are out of cards, you get points for cards left in opponents' hands as follows:

All cards through 9	Face Value
Reverse	20 Points
Skip	20 Points
Hit 2	20 Points
Discard All	30 Points
Trade Hands	30 Points
Wild	50 Points
Wild All Hit	50 Points
Wild Hit-Fire	50 Points

The WINNER is the first player to reach 500 points. However, the game may be scored by keeping a running total of the points each player is caught with at the end of each hand. When one player reaches 500 points, the player with the lowest points is the winner.

RENEGING

You may choose not to play a playable card from your hand. If so, you must hit the Launcher button. Your turn is then over.

PENALTIES

Any player making a card suggestion to another player must hit the Launcher button 4 times.

TWO PLAYER GAME

Rules for Two Players - Play UNO Attack! with two players with the following special rules:

1. Playing a Reverse card acts like a Skip. The player who plays the Reverse may immediately play another card.

2. The person playing a Skip card may immediately play another card.

3. When a Hit 2 card is played and your opponent has hit the Launcher button twice, the play is back to you.

CHALLENGE GAME

Challenge UNO Attack! - This game is scored by keeping a running total of what each player is caught with in their hand. As each player reaches a designated amount, we suggest 500, that player is eliminated from the game. When only two players are left in the game, they play head to head. (See Two Player Game section.) When a player reaches or exceeds the amount designated, they lose. The winner of that final hand is declared the winning player of the game.

THE MAKERS OF UNO FIND THIS VARIATION THE MOST CHALLENGING WAY TO PLAY.

**LOOK FOR OUR ENTIRE
FAMILY OF UNO® GAMES!**

**Original UNO®
Deluxe UNO®
My First UNO® Rugrats™
My First UNO® Sesame Street®
My First UNO® Winnie the Pooh
Barbie® UNO®
UNO Blitzo™
Handheld Electronic UNO®**

Each sold separately and subject to availability.

41943



© 2002 Mattel, Inc., El Segundo, CA 90245 U.S.A.
All Rights Reserved.
41943-0821 G1