

Barbie™ My First Skates™



Model Number: 77551

Please keep this instruction sheet for future reference, as it contains important information.

Wheel and size adjustments should be done by an adult.

For ages 2 years and up, shoe sizes 6-12.

My First Skates are designed to be worn on either foot.

Safety equipment is not included.

⚠ WARNING

To prevent injury, protective equipment should be worn. Not for children with a body weight of more than 44 lbs. (20 kg). Use helmet, wrist guards, knee pads, and elbow pads.

Message to Parents

Learning to skate is easy and fun with Barbie™ My First Skates. With three-way control, they make learning a breeze and provide hours of fun and exercise. Take a moment to review the warning statement and safety tips in these instructions with your child so your child knows how to use My First Skates correctly and safely.

Safety Tips

- Wear a helmet, knee pads, wrist guards and elbow pads to guard against bumps and bruises.
- Supervise a beginner skater. It helps to hold the beginner's hand and to guide the skater along a smooth, level surface.
- Wear shoes or sneakers, not open-toe shoes.
- Keep loose laces and pant legs away from the wheels.
- Select areas for skating which are free from obstacles.
- Avoid skating on streets, roadways and driveways which enter vehicle traffic routes.
- Never hitch a ride behind a bicycle or car.

Wheel Control Adjustment

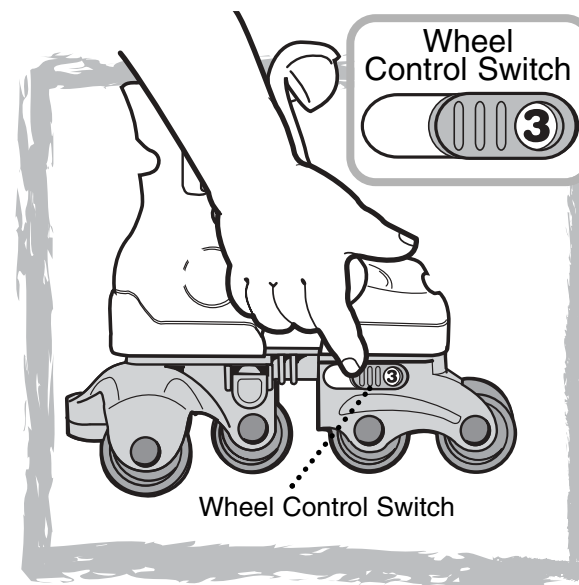

- Locate the wheel control switch on the side of the skate.
- Press and slide the wheel control switch to:

FULL STOP (WALK)

The second wheel completely locks. Your skater can walk on the skates to get used to them.

FORWARD ONLY

The second wheel locks to prevent the wheel from rolling backward. Your skater can roll forward. It is normal to hear a clicking sound in this mode.

FREE WHEELING

Your skater can roll forward and backward unrestricted.

Important!

- Make sure both skates are set to the same wheel control position.
- The wheel control function works only when your child is wearing and putting weight on the skates.



Discover what's possible... www.fisher-price.com

Fitting the Skates

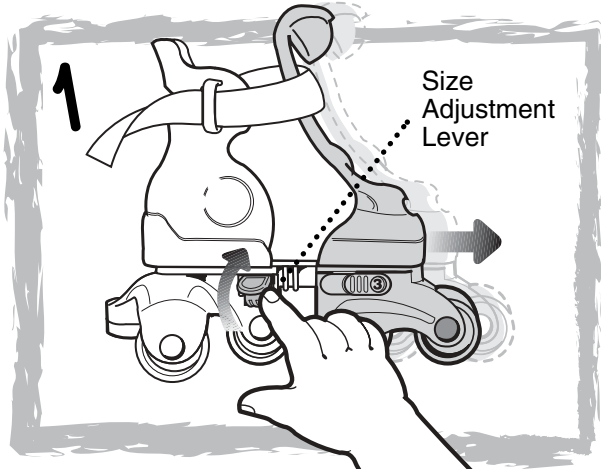

- Lift the size adjustment lever.
- Pull the front of the skate to the fully extended position.
- Repeat this procedure to open the other skate to the fully extended position.

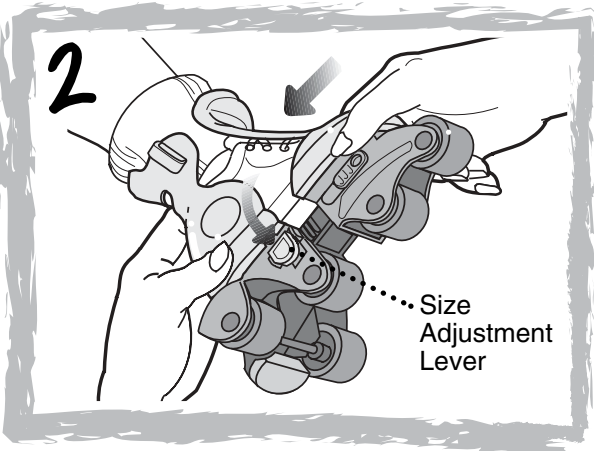

- Make sure your child is seated.
- Place your child's foot in the skate.
- Push the front of the skate to shorten it to the appropriate size for your child.
- Press the size adjustment lever down until it "snaps" into place.
- Adjust the size of the other skate to your child's other foot.

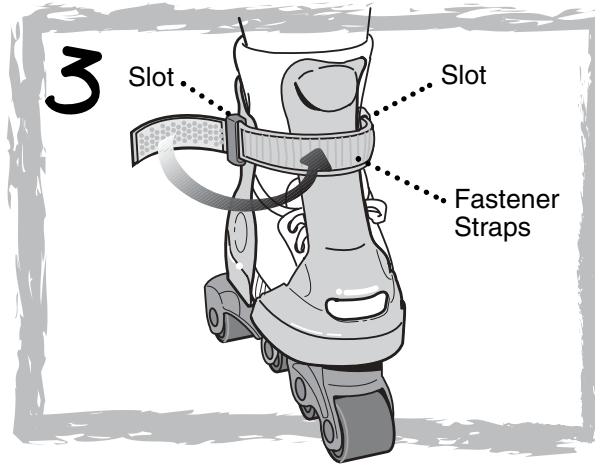

- Insert the fastener straps into the slots on the side of each skate.
- Pull the fastener straps tight and fold them back on themselves for a secure fit.

Care

- Periodically lubricate the rear axle on each skate with a little petroleum jelly.

Consumer Information

Questions? We'd like to hear from you!

Call Fisher-Price® Consumer Relations, toll-free at **1-800-432-5437**, 8 AM - 6 PM EST Monday through Friday. Hearing-impaired consumers using TTY/TDD equipment, please call 1-800-382-7470.

Or, write to: Fisher-Price® Consumer Relations, 636 Girard Avenue, East Aurora, New York 14052.

For other countries, outside the United States:

Canada: call **1-800-567-7724**, or write to: Mattel Canada Inc., 6155 Freemont Blvd., Mississauga, Ontario L5R 3W2.

Great Britain: telephone **01628 500302**.

Australia: Mattel Australia Pty. Ltd., 658 Church Street, Locked Bag #870, Richmond, Victoria 3121 Australia. Consumer Advisory Service 1300 135 312.

New Zealand: 16-18 William Pickering Drive, Albany 1331, Auckland.