



# Aquarium Cradle Swing



**Swing**  
(Seat moves front to back)



**Cradle**  
(Seat moves side to side)

**Model Number: 79667**

Please read these instructions before use of this swing.

Keep this instruction sheet for future reference, as it contains important information.

Adult assembly is required.

Tool needed for assembly: Phillips screwdriver (not included).

Requires four "D" (LR20) **alkaline** batteries for operation (not included).

Maximum Weight Limit: 24 lbs. (10.9 kg.)

**IMPORTANT!** If your child weighs less than 24 lbs., but is really active and appears to be able to climb out of the swing, immediately discontinue its use.

Product features and decorations may be different than shown in photos above.

**Fisher-Price®**

[www.fisher-price.com](http://www.fisher-price.com)

## Warnings and Caution

### **WARNING**

- To prevent serious injury or death from falls and being strangled in the restraint system:
  - Always use restraint system. Never rely on the tray to restrain child.
  - Never use with an active child who may be able to climb out of the seat.
- Never leave child unattended.

### **CAUTION**

This product contains small parts in its unassembled state. Adult assembly is required.

## Consumer Information

Occasionally a consumer may experience a problem with one of our products. If this should happen, please call us toll-free, rather than return this product to the store. Usually, we can solve the problem over the telephone or send you replacement parts. Please call Fisher-Price® Consumer Relations, toll-free at **1-800-432-5437**, 8 AM- 6 PM EST Monday through Friday. Hearing-impaired consumers using TTY/TDD equipment, please call 1-800-382-7470.

Or, write to:  
Fisher-Price®  
Consumer Relations  
636 Girard Avenue  
East Aurora, New York 14052

#### For countries outside the United States:

**CANADA**  
Questions? 1-800-567-7724, Mattel Canada Inc.,  
6155 Freemont Blvd., Mississauga, Ontario L5R 3W2.

**GREAT BRITAIN**  
Mattel UK Ltd, Vanwall Business Park, Maidenhead SL6 4UB. Helpline: 01628 500302.

**AUSTRALIA**  
Mattel Australia Pty. Ltd., 658 Church Street, Locked Bag #870, Richmond, Victoria 3121  
Australia. Consumer Advisory Service 1300 135 312.

**NEW ZEALAND**  
16-18 William Pickering Drive, Albany 1331, Auckland.

**ASIA**  
Mattel East Asia Ltd, Room 1106, South Tower, World Finance Centre, Harbour City,  
Tsimshatsui, HK, China.

## One (1) Year Limited Warranty

Fisher-Price, Inc., 636 Girard Avenue, East Aurora, New York 14052, warrants that the Ocean Wonders™ Aquarium Cradle Swing is free from all defects in material and workmanship when used under normal conditions for a period of one (1) year from the date of purchase.

Should the product fail to perform properly, we will repair or replace it at our option, free of charge. Purchaser is responsible for shipping the product to Fisher-Price Consumer Relations at the address indicated above and for all associated freight and insurance cost. Fisher-Price, Inc. will bear the cost of shipping the repaired or replaced item to you.

This warranty is void if the owner repairs or modifies the product. This warranty excludes any other liability other than that expressly stated above including but not limited to any incidental or consequential damages.

**SOME STATES DO NOT ALLOW THE EXCLUSION OR LIMITATION OF INCIDENTAL OR CONSEQUENTIAL DAMAGES, SO THE ABOVE LIMITATION OR EXCLUSION MAY NOT APPLY TO YOU.**

**THIS WARRANTY GIVES YOU SPECIFIC LEGAL RIGHTS AND YOU MAY ALSO HAVE OTHER LEGAL RIGHTS WHICH VARY FROM STATE TO STATE.**

## FCC Note (United States Only)

Note: This equipment has been tested and found to comply with the limits for a Class B digital device, pursuant to Part 15 of the FCC Rules. These limits are designed to provide reasonable protection against harmful interference in a residential installation. This equipment generates, uses and can radiate radio frequency energy and, if not installed and used in accordance with the instructions, may cause harmful interference to radio communications. However, there is no guarantee that interference will not occur in a particular installation. If this equipment does cause harmful interference to radio or television reception, which can be determined by turning the equipment off and on, the user is encouraged to try to correct the interference by one or more of the following measures:

- Reorient or relocate the receiving antenna.
- Increase the separation between the equipment and receiver.
- Consult the dealer or an experienced radio/TV technician for help.

Note: Changes or modifications not expressly approved by the manufacturer responsible for compliance could void the user's authority to operate the equipment.

# Parts

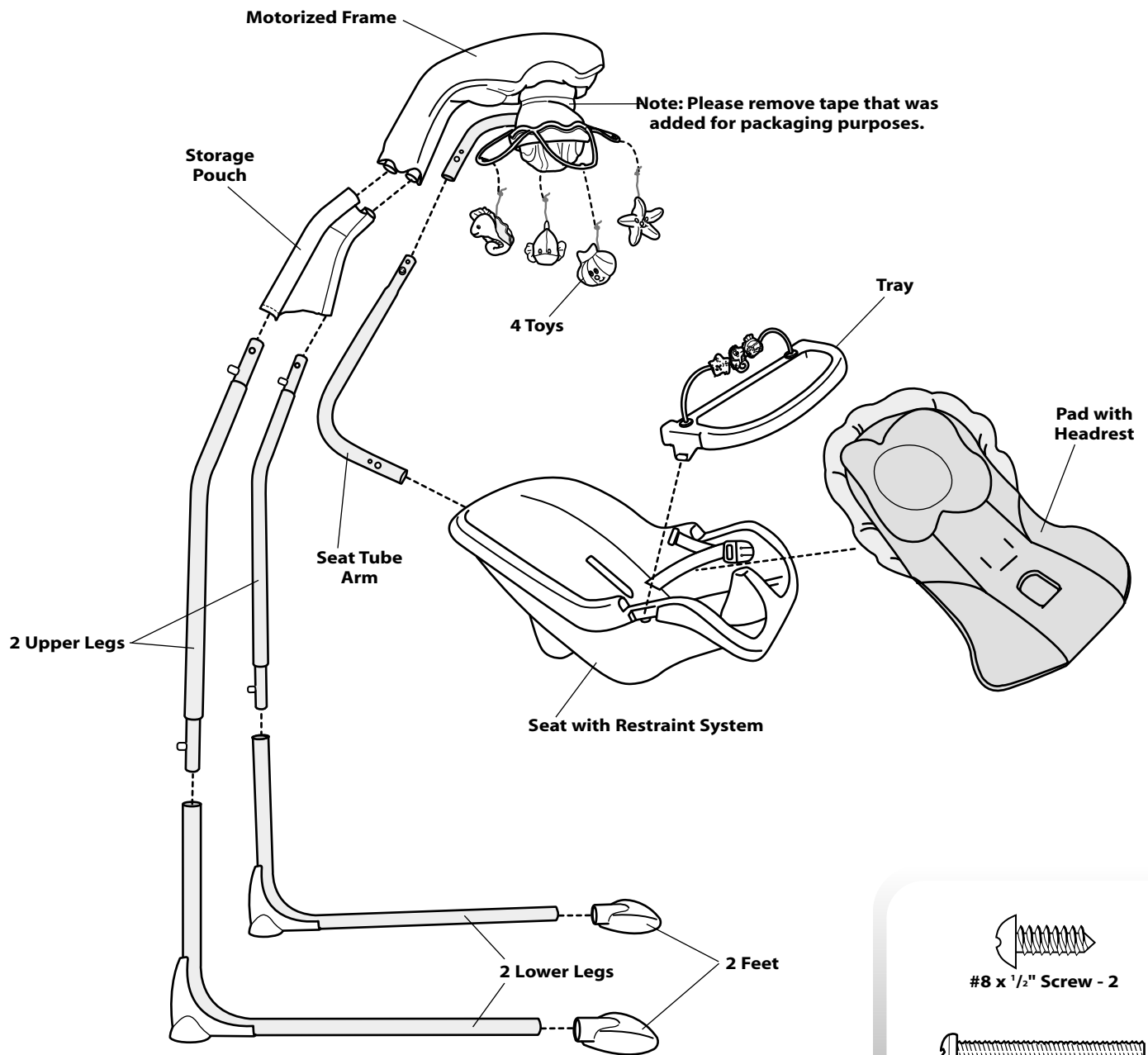

#8 x 1/2" Screw - 2



M5 x 30 mm Bolt - 2



M5 Lock Nut - 2

ALL SHOWN ACTUAL SIZE

# Assembly

**IMPORTANT!** Before each use or assembly, inspect this product for damaged hardware, loose joints, missing parts or sharp edges. **DO NOT** use if any parts are missing or broken. Contact Fisher-Price® for replacement parts and instructions if needed. Never substitute parts.

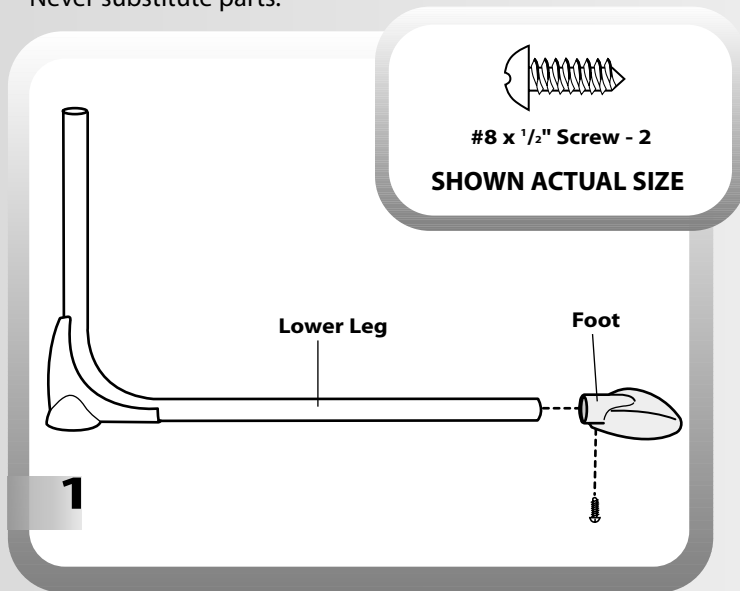

- Position a lower leg so that it stands on a flat surface, as shown.
- Fit a foot onto the end of the lower leg.
- Insert a #8 x 1/2" screw through the bottom of the foot and into the lower leg. Tighten the screw with a Phillips screwdriver. Do not over-tighten.
- Repeat this procedure to assemble the other foot to the other lower leg.

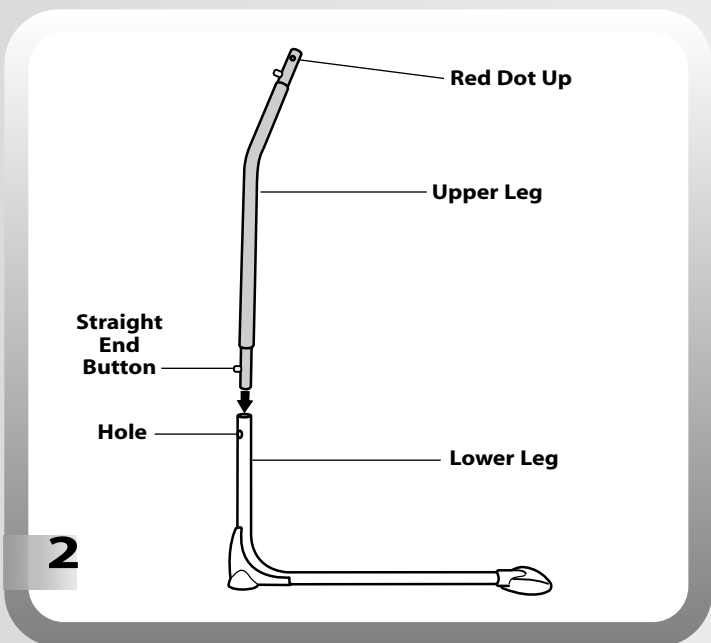

- Position an upper leg so that the **red dot is up**.
- While pressing the button on the **straight end** of an upper leg, insert the upper leg into a lower leg. Make sure the button on the upper leg **"snaps"** into the hole in the lower leg.
- Repeat this procedure to assemble the other upper leg to the other lower leg.

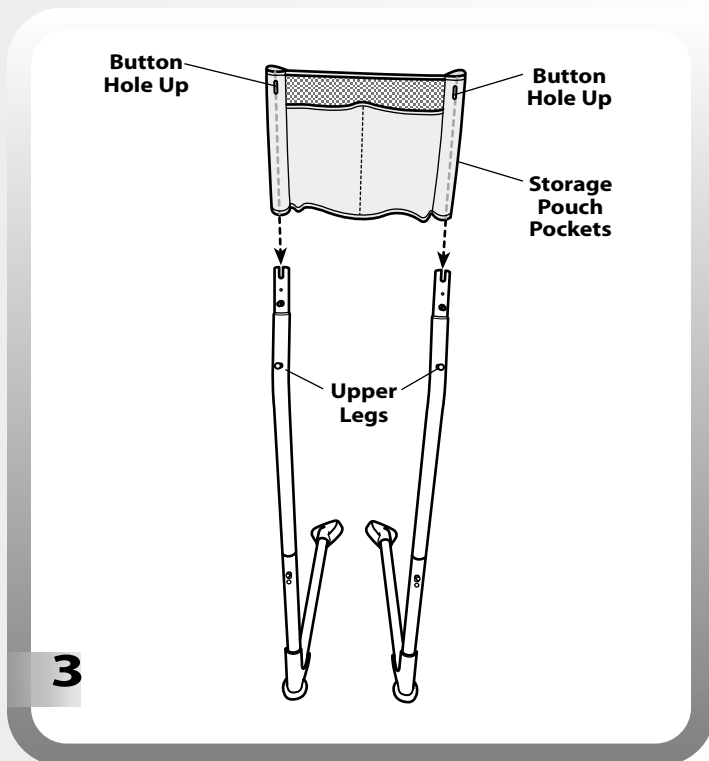

- Position the storage pouch with the pockets toward you, and the button holes are up.
- Position the legs so that the feet are away from you.
- Slide the storage pouch onto the upper legs.

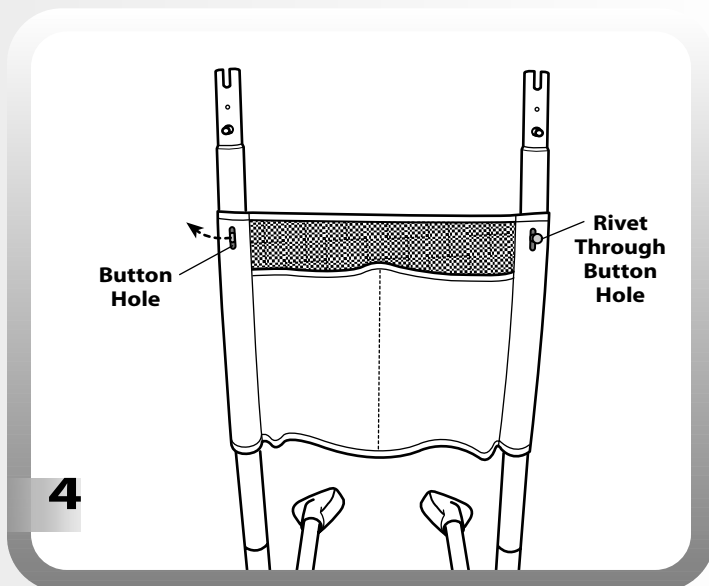

- Fit the rivets on the upper legs through the button holes in top ends of the storage pouch.

# Assembly

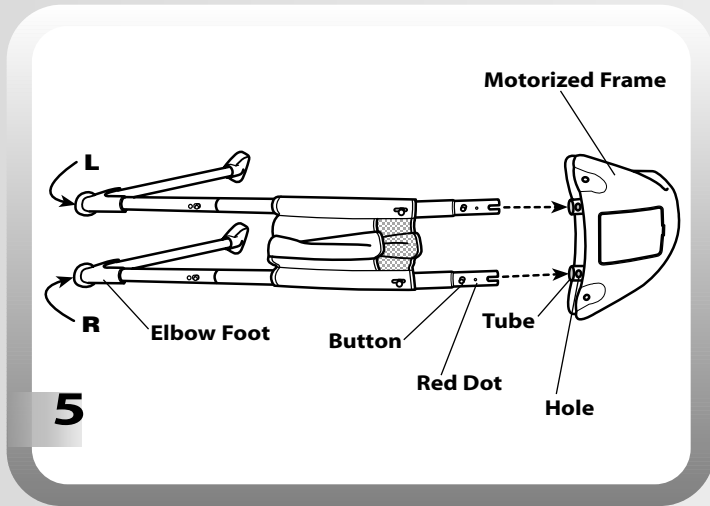

- Locate the **R** and **L** on the underside of each elbow foot. The **R** indicates the right leg. The **L** indicates the left leg.
- While pressing the upper button on the right leg, fit it into the tube in the motorized frame. Make sure the upper button on the right leg “snaps” into the hole in the tube.
- Repeat this procedure to assemble the left leg to the motorized frame.
- When the legs are assembled correctly to the tubes in the motorized frame, you should **not** see the red dots.

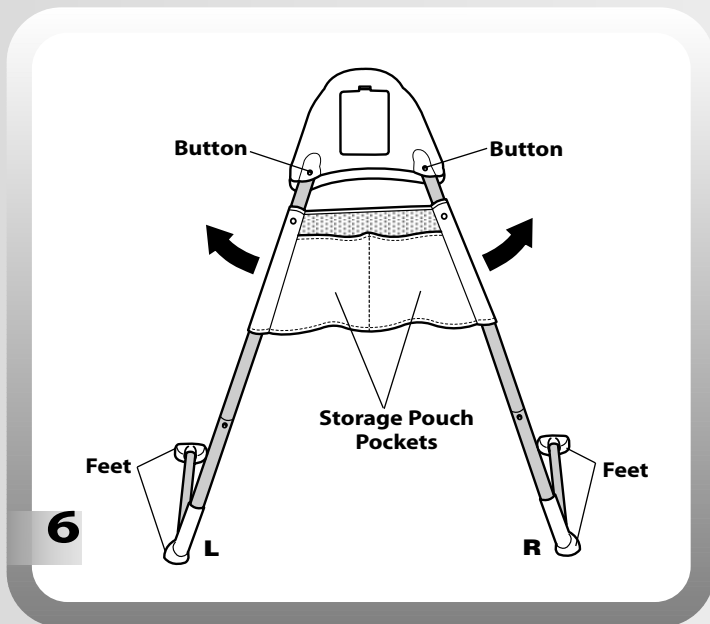

- Stand the assembly upright.
- Pull the legs out so that the buttons “snap” into the holes in the motorized frame. If the buttons do not “snap” into the holes, you probably have not assembled the storage pouch correctly. Please refer back to assembly steps 3 and 4.
- When standing behind the product, all four feet should be **flat** upon the floor. And, check for an **L** marking on the left foot and an **R** marking on the right foot.
- If the feet are not flat upon the floor, or the left and right feet have been reversed, remove both lower legs from the upper leg. Replace them onto the opposite upper leg.

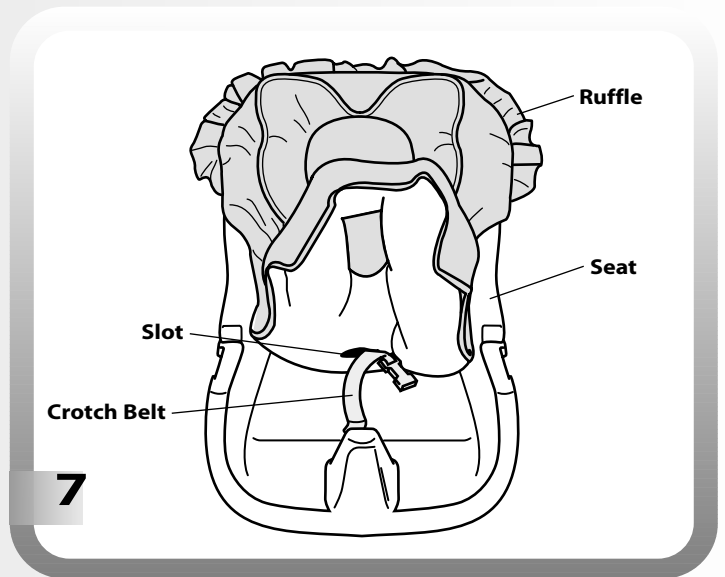

- Position the seat upright.
- Place the pad onto the seat with the ruffle toward the top of the seat.
- Fold the bottom of the pad up. Insert the crotch belt through the slot in the pad. Make sure the crotch belt is not twisted.

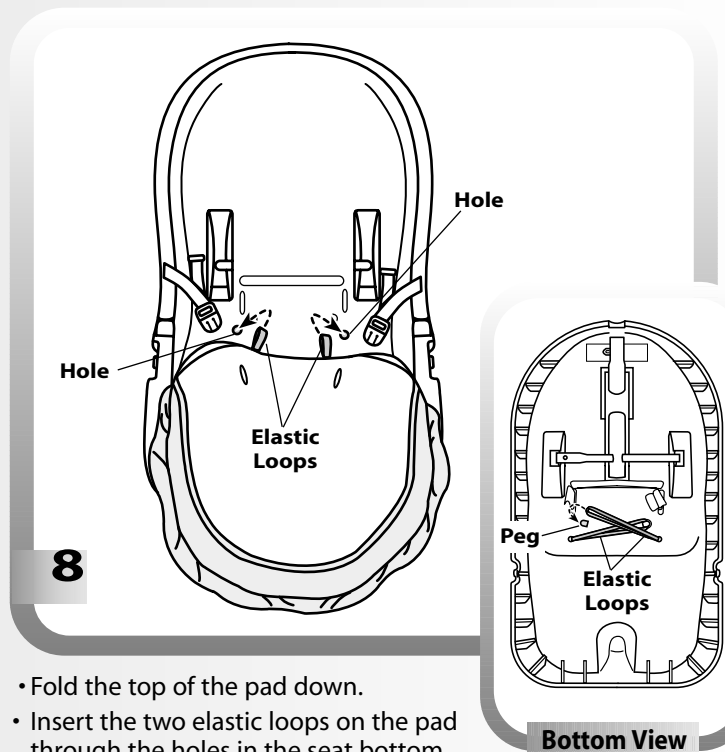

- Fold the top of the pad down.
- Insert the two elastic loops on the pad through the holes in the seat bottom
- While holding the elastic loops in place, turn the seat face down.
- Hook the elastic loop on the left side onto the peg on the right side.
- Hook the elastic loop on the right side onto the peg on the left side.

**Hint:** The elastic loops should cross over each other when attached correctly to the pegs.

# Assembly

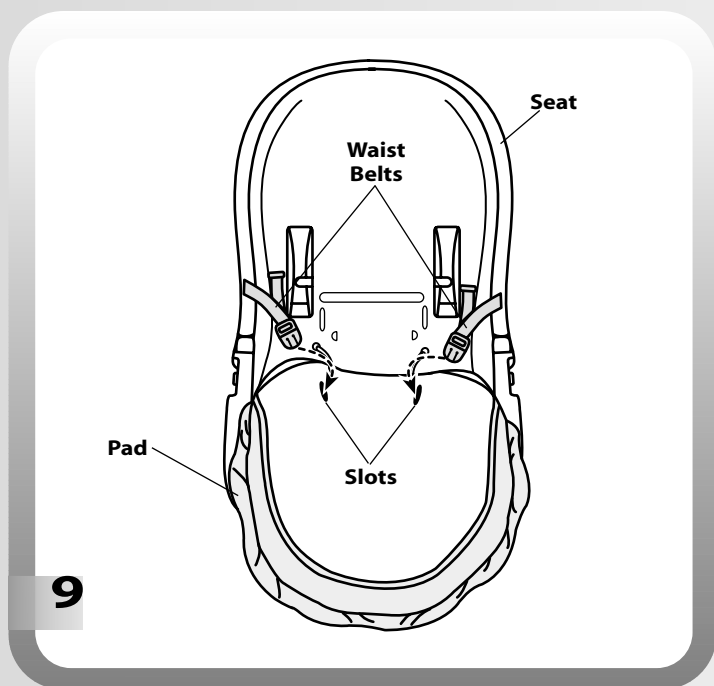

- Fold the top of the pad down. Insert the waist belts through the slots in the pad. Make sure the waist belts are not twisted.

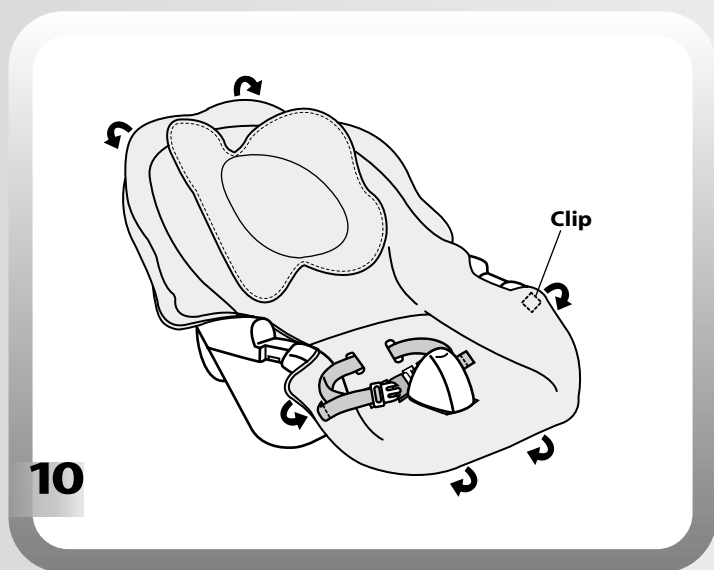

- Turn the seat upright.
- Fit the pad edges around the rim of the seat.
- Hook the two fastener straps on each side of the pad onto the rim on each side of the seat.

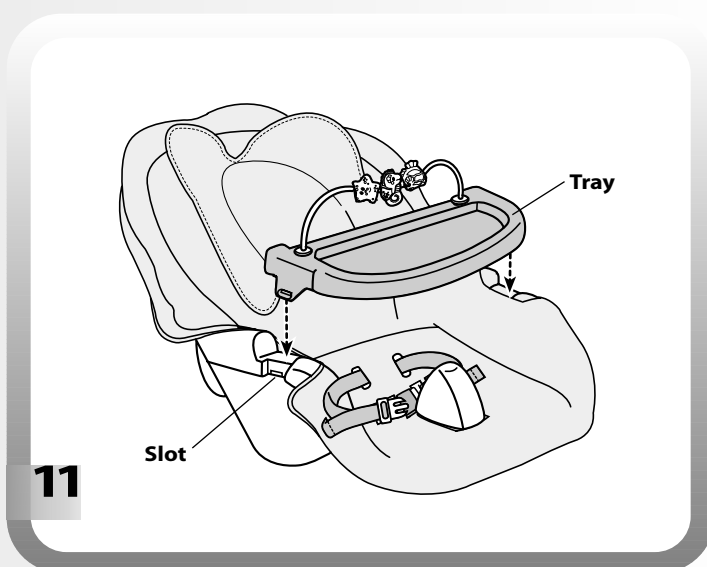

- Insert the tray tabs into the slots in each side of the seat.

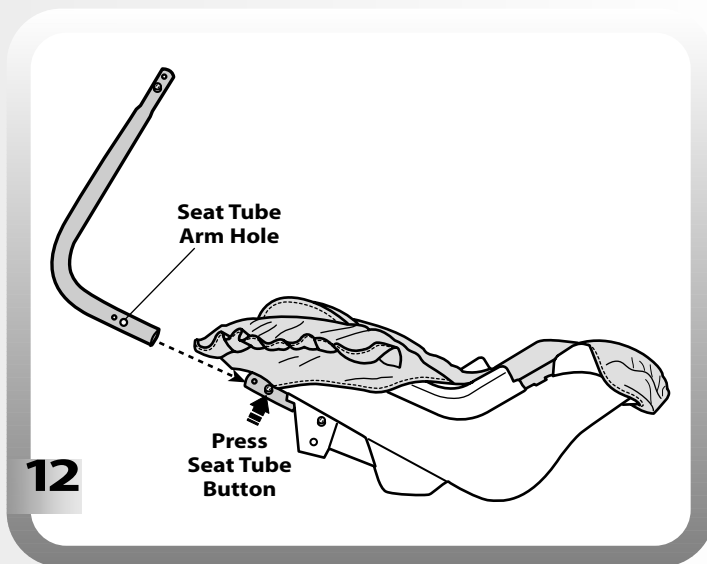

- While pressing the button on the seat tube, slide the seat tube arm onto the seat tube. Make sure the button on the seat tube **"snaps"** into the hole in the seat tube arm.

# Assembly

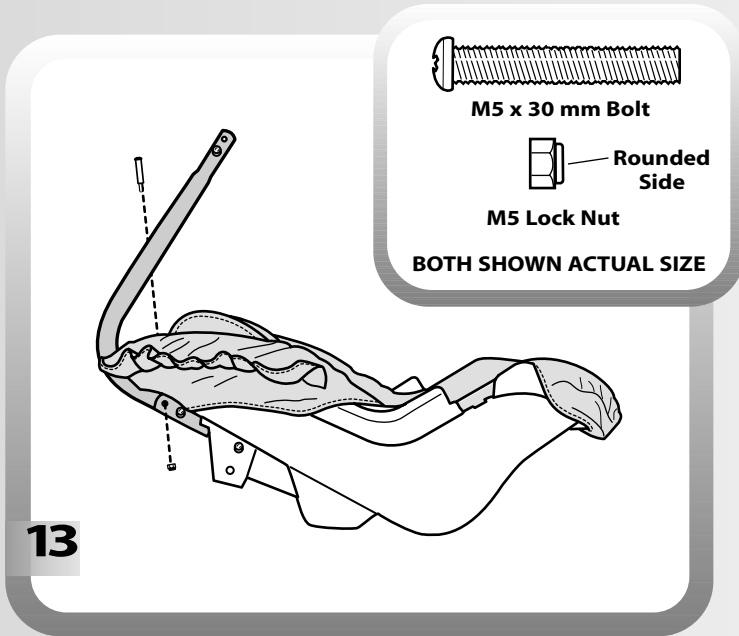

13

- Fit an M5 lock nut into the recess in the seat tube. **Make sure the rounded side of the lock nut faces out.**
- Insert an M5 x 30 mm screw into the opposite side of the seat tube.

Tighten the screw with a Phillips screwdriver. Do not over-tighten.

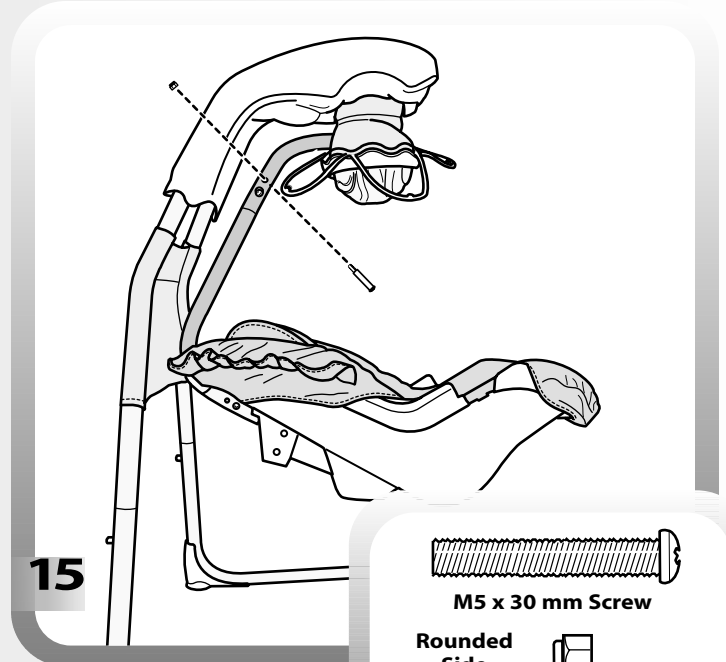

15

- Fit an M5 lock nut into the recess in the motorized frame tube. **Make sure the rounded side of the lock nut faces out.**
- Insert an M5 x 30 mm screw into the smaller hole in the motorized frame tube.
- Tighten the screw with a Phillips screwdriver. Do not over-tighten.

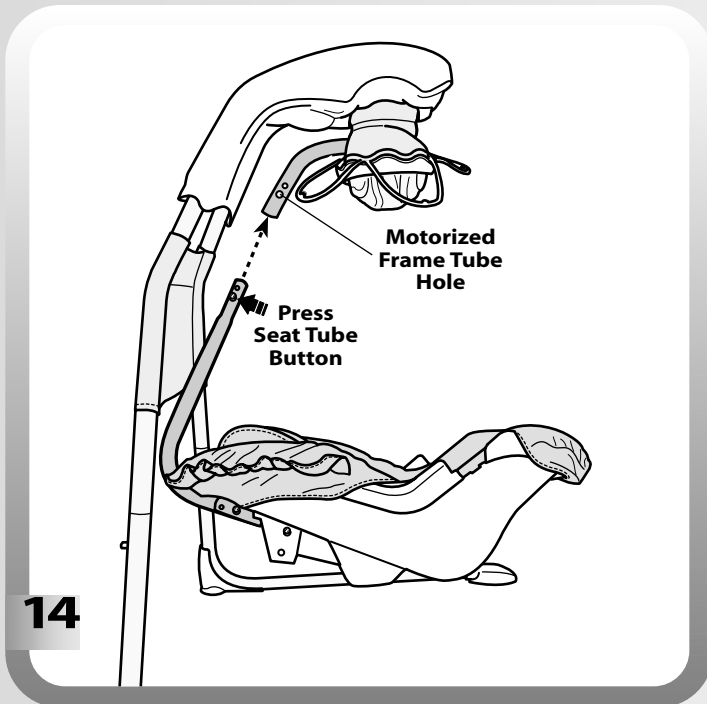

14

- Press the button on the seat tube and slide the seat tube into the motorized frame tube. Make sure the button on the seat tube **"snaps"** into the larger hole in the motorized frame tube.

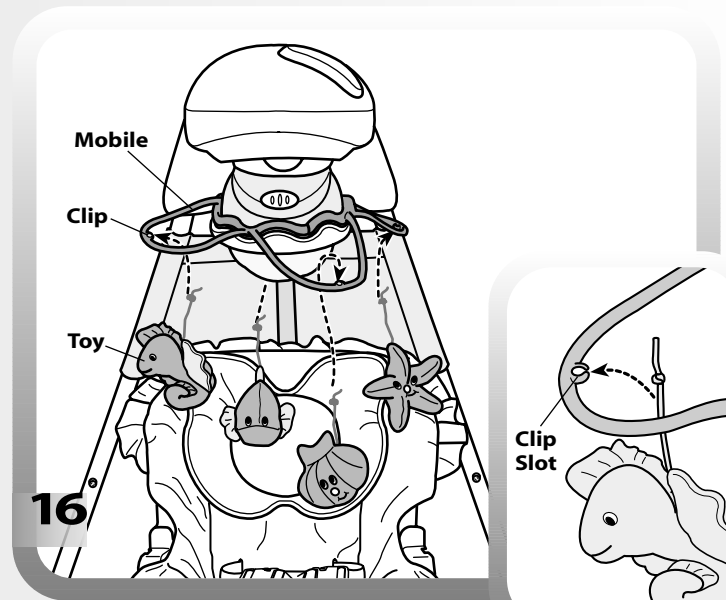

16

- Fit the string (below the knot) of a toy through the slot in a clip on the mobile.
- Pull down on the toy to be sure it is secure on the mobile.
- Repeat this procedure to assemble the other three toys to the mobile.

# Battery Installation

# Battery Safety Information

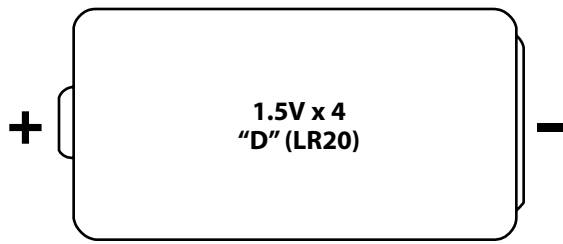

SHOWN ACTUAL SIZE

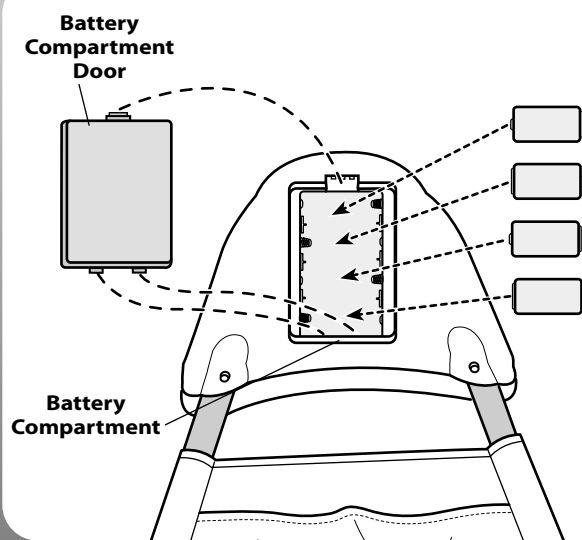

- Using a coin, press the tab on the battery compartment door and remove it.
- Insert four "D" (LR20) **alkaline** batteries, as indicated inside the battery compartment.

**Hint:** We recommend using **alkaline** batteries for longer battery life.

- Replace the battery compartment door.

**Hint:** If the swinging motion becomes noticeably slower, or sounds and lights become faint or stop, remove the batteries and replace them with four, new "D" (LR20) **alkaline** batteries. Dispose of exhausted batteries properly.

Batteries may leak fluids that can cause a chemical burn injury or ruin your product. To avoid battery leakage:

- Do not mix old and new batteries or batteries of different types: alkaline, standard (carbon-zinc) or rechargeable (nickel-cadmium).
- Insert batteries as indicated inside the battery compartment.
- Remove batteries during long periods of non-use. Always remove exhausted batteries from the product. Dispose of batteries safely. Do not dispose of batteries in a fire. The batteries may explode or leak.
- Never short-circuit the battery terminals.
- Use only batteries of the same or equivalent type as recommended.
- Do not charge non-rechargeable batteries.
- Remove rechargeable batteries from the product before charging.
- If removeable, rechargeable batteries are used, they are only to be charged under adult supervision.



# Swing, Waterglobe and Mobile Use

**IMPORTANT!** Before each use or assembly, inspect this product for damaged hardware, loose joints, missing parts or sharp edges. **DO NOT** use if any parts are missing or broken. Contact Fisher-Price® for replacement parts and instructions if needed. Never substitute parts.

## To Unfold

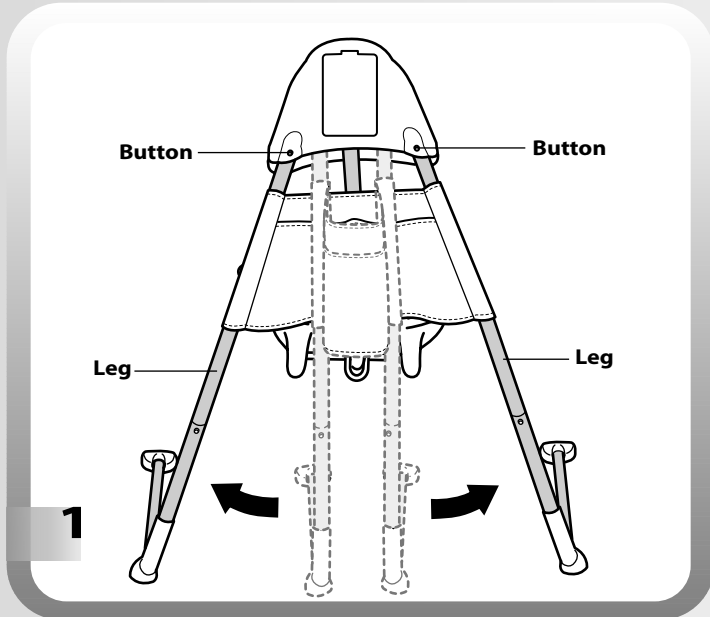

- Firmly pull the legs outward. Make sure the buttons snap into the notches in the motorized frame.
- Check to be sure the legs are locked into position by pushing the legs inward. The legs should not move.

## Restraint Belts

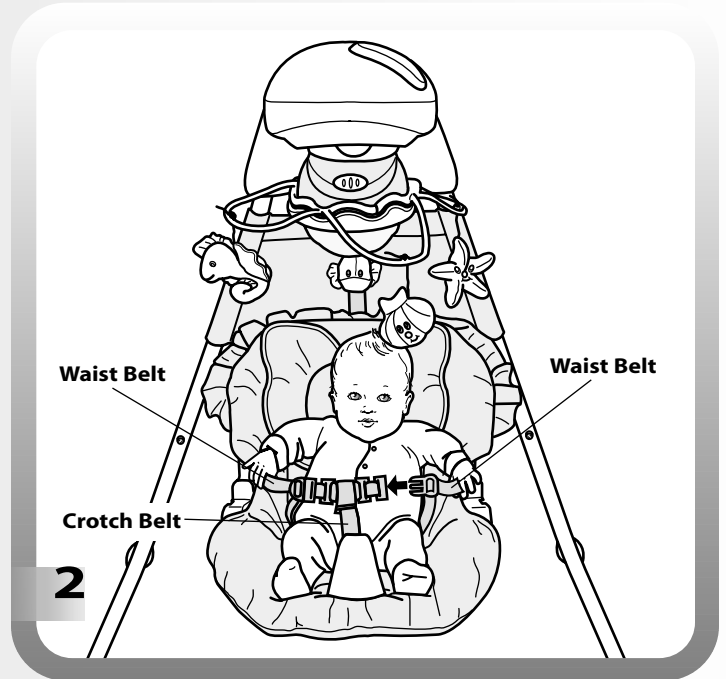

- Place your child in the seat.
- Pull the crotch belt up between your child's legs and fasten both waist belts to the crotch belt. Make sure you hear a "click" on both sides.

## WARNING

- To prevent serious injury or death from falls and being strangled in the restraint system:
  - Always use restraint system. Never rely on the tray to restrain child.
  - Never use with an active child who may be able to climb out of the seat.
- Never leave child unattended.

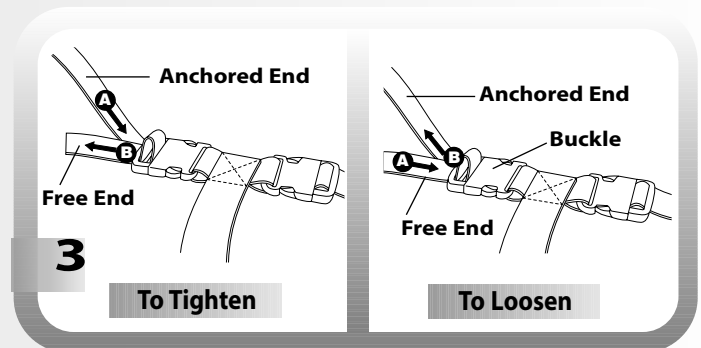

### To tighten the waist belts:

- Feed the anchored end of the waist belt up through the buckle to form a loop **A**. Pull the free end of the waist belt **B**.

### To loosen the waist belts:

- Feed the free end of the waist belt up through the buckle to form a loop **A**. Enlarge the loop by pulling on the end of the loop toward the buckle. Pull the anchored end of the waist belt to shorten the free end of the waist belt **B**.

**Note:** Check to be sure the restraint is securely attached by pulling it away from your child.

# Swing, Waterglobe and Mobile Use

## Adjust Swing Motions

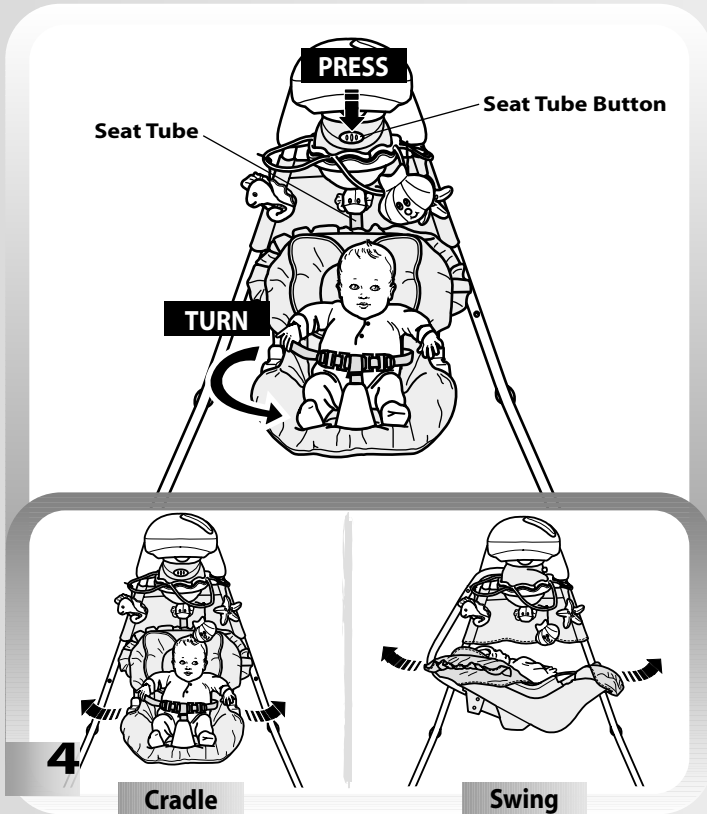

You can adjust the motion of the swing: side to side or front to back.

- Press the seat tube button to unlock the seat tube.
- Rotate the seat tube to the desired position.

## Adjust Seat to Recline or Upright

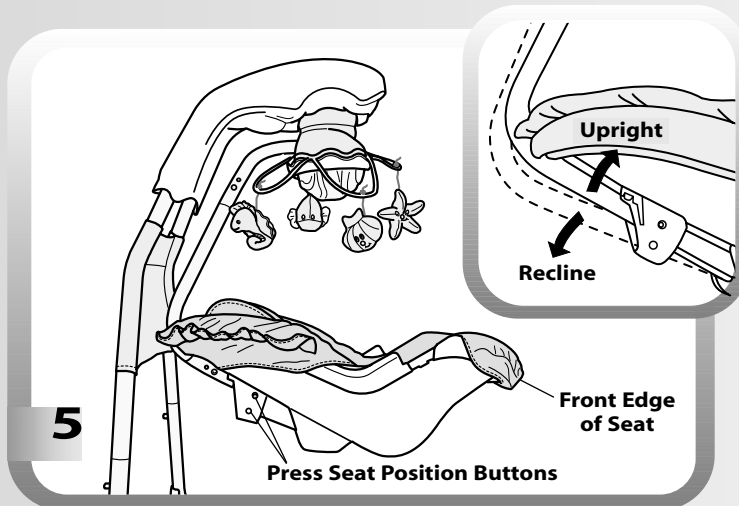

You can adjust the seat to two different positions: Recline or Upright.

- From behind the seat, press both seat position buttons.
- Push the seatback up until the buttons “snap” into the upright position.
- Push the seatback down until the buttons “snap” into the recline position.

## Using the Tray

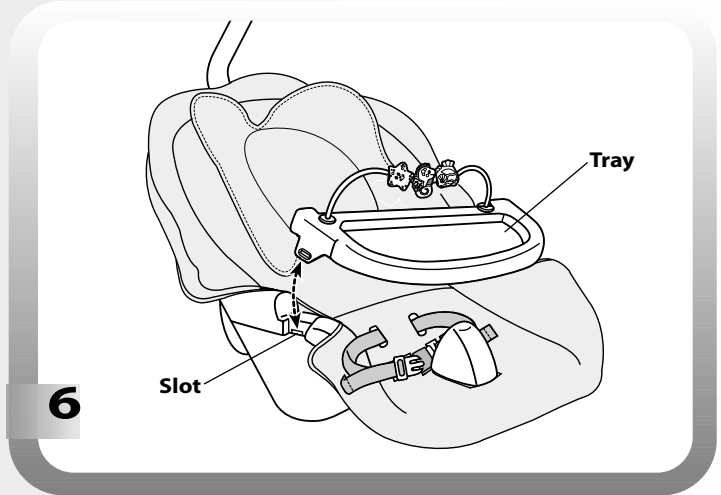

- Fit the tabs on the tray into the slots in the sides of the seat.
- To remove the tray, pull one edge of the tray out and lift.

## Storage

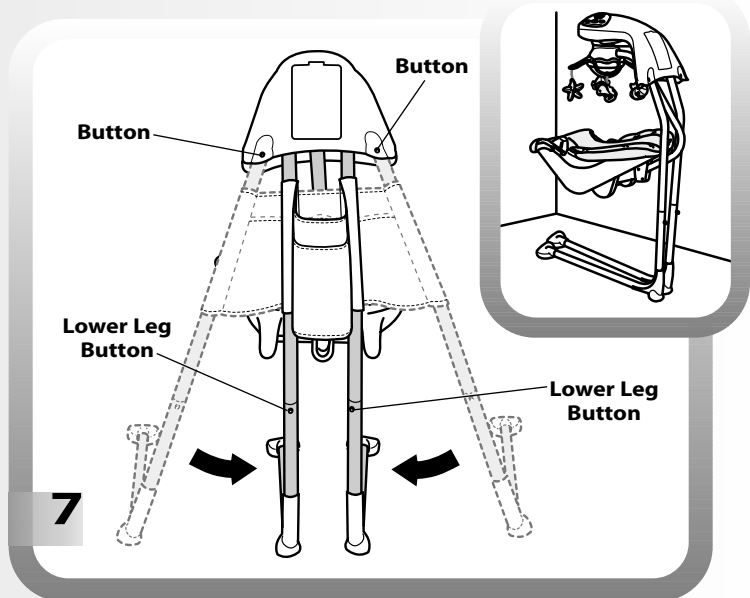

- Press the buttons on the back of the motorized frame while pushing the legs inward.
- Lean the swing frame against a wall for storage.

**IMPORTANT!** Remove the batteries for long-term storage.

*Hint:* The legs may be disassembled for long-term storage. Press the button on each lower leg and remove them from the upper legs.

# Swing, Waterglobe and Mobile Use

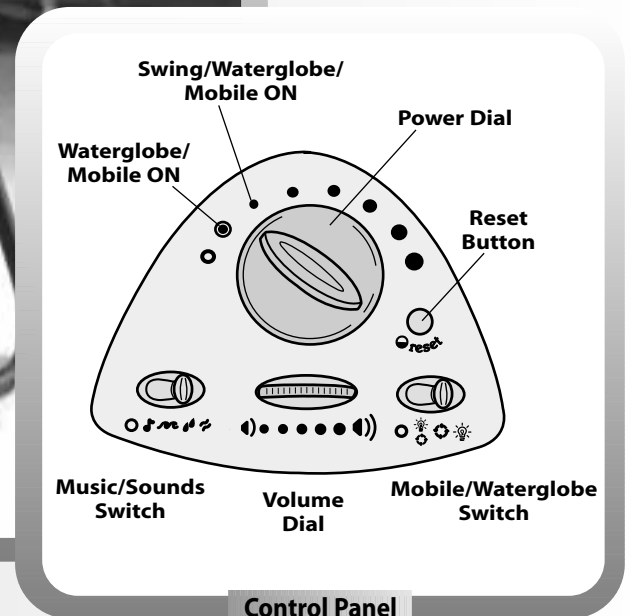
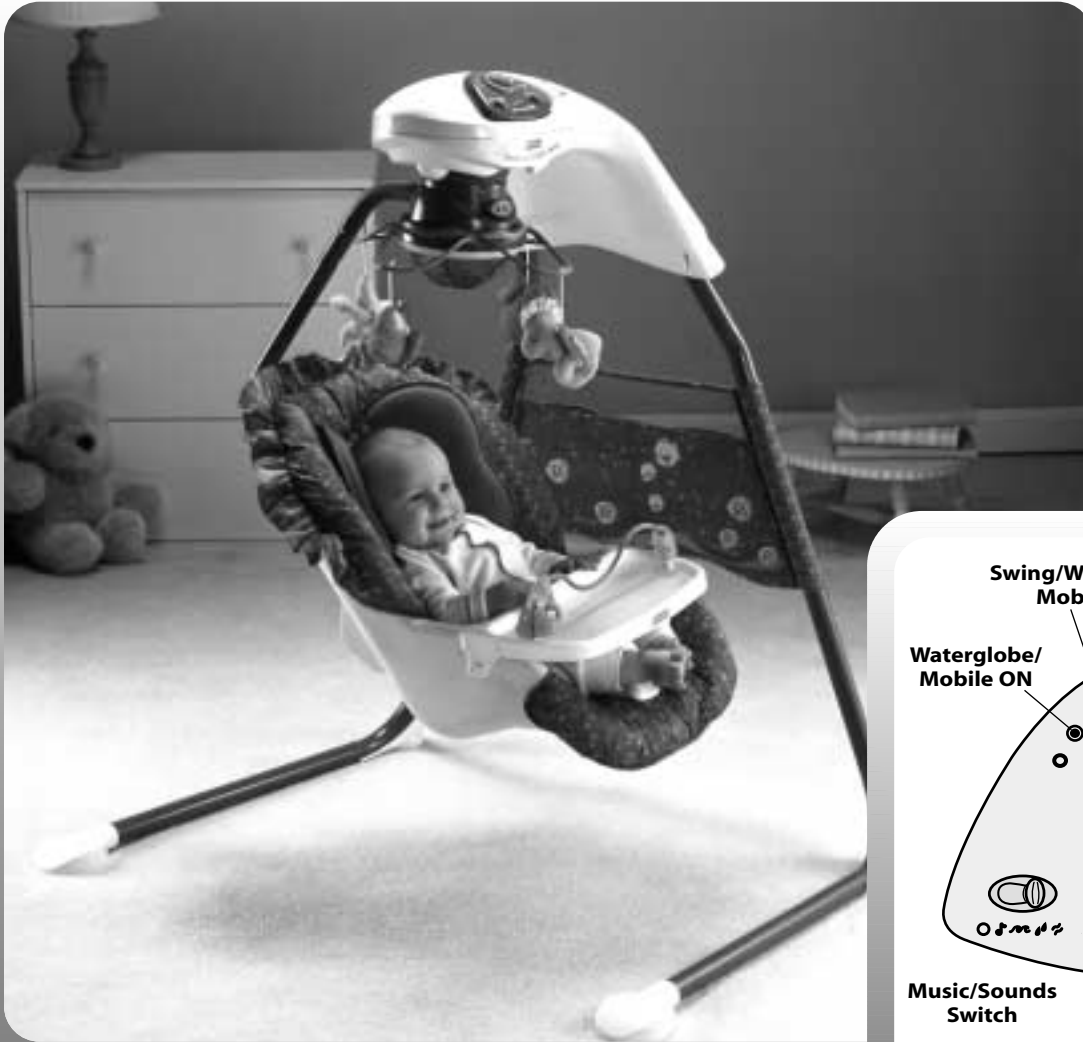

## Swing

- Turn the **power dial** to the ON position ●. The swing begins swinging.
- Select any of six speed settings ●●●●●●.
- Be sure to turn swinging OFF ○ when not in use.

### Hints:

- As with most battery-powered swings, a heavier child will reduce the amount of swinging motion on all settings. In most cases, the low setting works best for a smaller child while the high setting works best for a larger child.
- If the low setting provides too much swinging motion for your child, try placing one end of a blanket underneath your child and let the other end of the blanket drape down while swinging.

## Waterglobe, Mobile, Music and Sounds

Turn the power dial to ● to turn power ON for waterglobe, mobile, music and sounds.

**Hint:** The swing does not work on this power dial setting ○. If you'd like to use the waterglobe, mobile, music or sounds and swing at the same time, turn the power dial to any of the six speed settings ●●●●●●.

### To select waterglobe/mobile, slide switch to:

- Mobile
- Lights (Waterglobe)
- Mobile and Lights (Waterglobe)
- Mobile and Lights Off (Waterglobe)

















### To select sounds or music, slide switch to:

- Music
- Waves
- Rain
- Babbling brook
- Music and Sounds Off

To select a comfortable listening setting: turn the volume dial ●●●●●●).

**Hint:** The waterglobe, mobile, music or sounds will turn off after approximately seven minutes. To restart waterglobe, mobile, music or sounds, press the reset button ● for another seven minutes of use.

# Problems and Solutions

Problem	Probable Cause	Solution
Motor is not running; no swinging	Power is not on	Turn the power dial to one of six settings.
	Batteries incorrectly installed	Remove the batteries and replace in correct orientation, as indicated inside the battery compartment.
	Dead batteries	Replace all four batteries with four, fresh "D" <b>alkaline</b> batteries.
Motor is running but swinging stops after a few minutes	Need to start swinging motion	To start swinging motion, give the seat a light push.
	Swing motion setting is inappropriate for child's weight	Adjust the power dial to a higher speed setting and give the seat a light push.
	Weak batteries	Replace all four batteries with four, fresh "D" <b>alkaline</b> batteries.
No difference noticed in swinging motion after power dial is adjusted	Swing did not have sufficient time to adjust to different setting	Allow the swing time to adjust to new setting.
	Weak batteries	Replace all four batteries with four, fresh "D" <b>alkaline</b> batteries.
Swinging motion too high even at the lowest setting	Normal operation	To slow swinging, place one end of a blanket underneath your child and let the other end of the blanket drape down while swinging.
Waterglobe (lights)/mobile, music/sounds do not work and swing is off	Power dial is not on correct setting	Position the power dial to the  position.
	Dead batteries	Replace all four batteries with four, fresh "D" <b>alkaline</b> batteries.
	Waterglobe (lights)/mobile, music/sounds turn off automatically after seven minutes	Press the reset button  to restart waterglobe (lights)/mobile, music/sounds for another seven minutes.
Music/sounds do not work (and power dial is set to  )	Music/sounds switch is in OFF  position	Slide music/sounds switch to desired setting  .
	Music/sounds turn off automatically after seven minutes	Press the reset button  to restart music/sounds for another seven minutes.
Waterglobe (lights) does not work (and power dial is set to  )	Mobile/waterglobework switch is in OFF  position or mobile only  position	Slide mobile/waterglobe (lights) switch to desired setting  .
	Waterglobe (lights)/mobile turn off automatically after seven minutes	Press the reset button  to restart waterglobe (lights)/mobile for another seven minutes.
Mobile does not work (and power dial is set to  )	Mobile/waterglobe (lights) switch is in OFF  position or waterglobe only  position	Slide mobile/waterglobe (lights) switch to desired setting  .
	Mobile/waterglobe (lights) turn off automatically after seven minutes	Press the reset button  to restart mobile/waterglobe (lights) for another seven minutes.

## Care

- Remove the tray from the seat.
- Unbuckle the restraint system.
- Remove the pad elastic loops from the pegs and unfasten the pad fasteners from the seat.
- Remove the pad from the restraint system.
- Remove the toys from the mobile.
- Machine wash the pad and toys in cold water with a mild detergent. Do not use bleach. Tumble dry on low heat and remove promptly.
- To clean the seat, restraint system, tray, mobile, storage pouch and motorized frame, use a mild cleaning agent and damp cloth. Rinse with clean water to remove residue.
- Replace the pad onto the seat. Replace the toys on the mobile.
- Periodically check the swing for loose fasteners or broken parts and tighten as needed.