



www.fisher-price.com



GeoTrax

Rail & Road System

Mix 'n Go Work Crew™

Battery Information

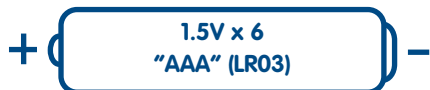

SHOWN ACTUAL SIZE

We recommend the use of alkaline batteries for longer battery life.

Battery Installation

Engine

- Locate the battery compartment on the back of the engine
- Loosen the screws in the battery compartment door with a Phillips screwdriver. Lift the battery compartment door and insert three "AAA" (LR03) alkaline batteries.
- Close the battery compartment door and tighten the screws with a Phillips screwdriver. Do not over-tighten.

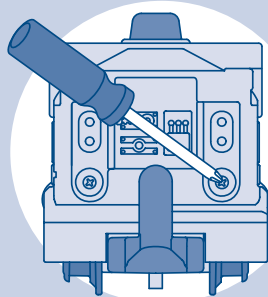

Remote Controller

- Locate the battery compartment on the side of the remote controller.
- Loosen the screw in the battery compartment door with a Phillips screwdriver. Remove the battery compartment door and insert three "AAA" (LR03) alkaline batteries.
- Replace the battery compartment door and tighten the screw with a Phillips screwdriver. Do not over-tighten.

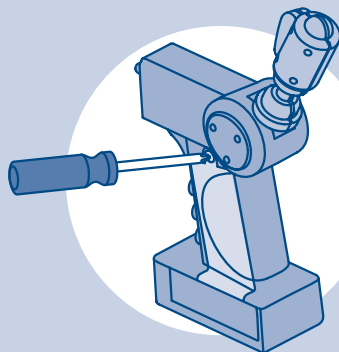

Battery Safety Information

Batteries may leak fluids that can cause a chemical burn injury or ruin your toy. To avoid battery leakage:

- Do not mix old and new batteries or batteries of different types: alkaline, standard (carbon-zinc) or rechargeable (nickel-cadmium).
- Insert batteries as indicated inside the battery compartment.
- Remove batteries during long periods of non-use. Always remove exhausted batteries from the toy. Dispose of batteries safely. Do not dispose of batteries in a fire. The batteries may explode or leak.
- Never short-circuit the battery terminals.
- Use only batteries of the same or equivalent type, as recommended.
- Do not charge non-rechargeable batteries.
- Remove rechargeable batteries from the toy before charging.
- If removable, rechargeable batteries are used, they are only to be charged under adult supervision.

Your child is bound for a world of adventure!

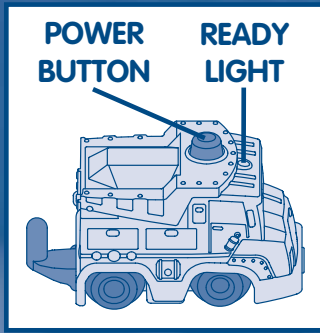

All Aboard!

- Hook the cars together and place them on the track. Make sure the engine is in front.

Hint: We do not recommend using the engine on carpets. For best performance, use on the track provided or hard, flat surfaces.

3-Position Remote Controller

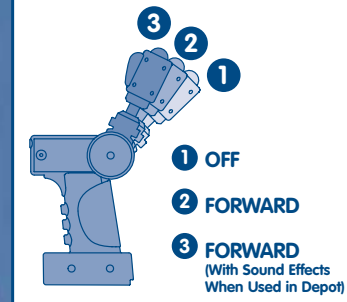

- Press the power button on top of the engine. The ready light turns on.
- Hold the remote controller with the stick facing you. Point the remote controller toward the engine and push the stick forward. The engine moves forward around the track.
- To stop the engine, pull the stick backwards to the stop position.

! WARNING
To prevent entanglement, keep hair away from wheels.

Hint: If you do not operate the remote controller for a few minutes, the engine shuts off and the ready light turns off. Press the engine power button, and operate the remote controller to restart.

The more you collect, the more fun it gets!



Each sold separately & subject to availability.

Fun Train Sounds with Tracktown Railway™ sold separately

You can use this toy with the Tracktown Railway™ to hear fun sound effects

- Place the remote controller into any of four the grooves in the depot.
- Press the power button on top of the engine. The ready light turns on.
- Push and hold the stick on the remote controller all the way forward.
- You'll hear fun sound effects as the engine heads around the track.

- To stop the engine, pull the stick back to the stop position.

Hint: This toy works best if you have a clear path between the remote controller and the engine. Point the remote controller at the engine. The maximum range of the remote controller is about 12 feet.

Hint: Sound effects can only be heard when remote controller is in the depot.

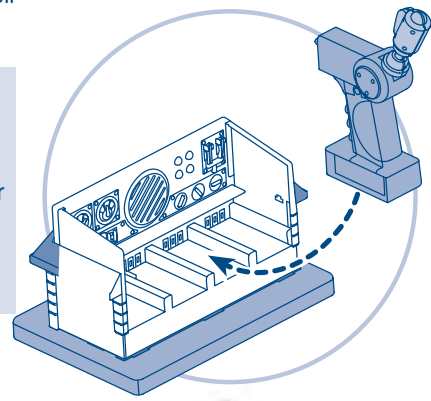

Troubleshooting

SYMPTOM	SOLUTION
Engine drives slowly	<p>Battery power in the engine may be weak. Replace all three batteries in the engine with fresh, alkaline batteries.</p> <p>The wheels on the engine or attached cars may be dirty. Wipe them with a clean cloth.</p>
Engine does not respond to the remote controller	<p>Battery power in the remote controller may be weak. Replace all three batteries in the remote controller with fresh, alkaline batteries.</p> <p>You may be beyond the maximum range of the remote controller which is about 12 feet.</p> <p>You may not have a clear path between the remote controller and the engine. This toy works best when there are no obstructions between the engine and the remote controller.</p> <p>Bright sunlight or fluorescent lights may affect the range of the remote controller. Try dimming the room you are playing in.</p> <p>The engine may have shut off. If you do not operate the remote controller for a few minutes, the engine shuts off automatically and the ready light turns off. Press the power button on the engine, and operate the remote controller to restart.</p>

FCC Note (United States Only)

Note: This equipment has been tested and found to comply with the limits for a Class B digital device, pursuant to Part 15 of the FCC Rules. These limits are designed to provide reasonable protection against harmful interference in a residential installation. This equipment generates, uses and can radiate radio frequency energy and, if not installed and used in accordance with the instructions, may cause harmful interference to radio communications. However, there is no guarantee that interference will not occur in a particular installation. If this equipment does cause harmful interference to radio or television reception, which can be determined by turning the equipment off and on, the user is encouraged to try to correct the interference by one or more of the following measures:

- Reorient or relocate the receiving antenna.
- Increase the separation between the equipment and receiver.
- Consult the dealer or an experienced radio/TV technician for help.

Note: Changes or modifications not expressly approved by the manufacturer responsible for compliance could void the user's authority to operate the equipment.

(ENG) ICES-003 (FR) NMB-003

(ENG) This Class B digital apparatus complies with Canadian ICES-003

(FR) Cet appareil numérique de la classe B est conforme à norme NMB-003 du Canada

Fisher-Price®

GeoTrax™

Rail & Road System

www.fisher-price.com

Questions? We'd like to hear from you!

Call Fisher-Price® Consumer Relations, toll-free at **1-800-432-5437**, 8 AM - 6 PM EST Monday through Friday. Hearing-impaired consumers using TTY/TDD equipment, please call 1-800-382-7470. Or, write to: Fisher-Price® Consumer Relations, 636 Girard Avenue, East Aurora, New York 14052, U.S.A.

Please keep this instruction sheet for future reference, as it contains important information.

Adult Assembly is required.
No tools needed for assembly.

Wipe the toy with a clean damp cloth.
Do not immerse.

For other countries outside the United States:

Canada: call 1-800-567-7724, or write to: Mattel Canada Inc., 6155 Freemont Blvd., Mississauga, Ontario L5R 3W2.

Great Britain: telephone 01628 500302. **Australia:** Mattel Australia Pty. Ltd., 658 Church Street, Locked Bag #870, Richmond, Victoria 3121 Australia. Consumer Advisory Service 1300 135 312. **New Zealand:** 16-18 William

Pickering Drive, Albany 1331, Auckland. **Asia:** Mattel East Asia Ltd, Room 1106, South Tower, World Finance Centre, Harbour City, Tsingshatsui, HK, China.

