

BATTERY INFORMATION

BATTERY INSTALLATION

- Unscrew and lift away cover from side of product.
- Replace batteries as indicated inside the battery compartment.
- Batteries included are for demonstration purposes only.
- For longer life use only alkaline batteries.
- If the product begins to malfunction, check the battery installation. You may need to reset the electronics by removing the batteries and reinstalling them. If the product continues to malfunction or no longer operates, remove the batteries from the toy and replace them with fresh batteries.
- Requires 3 "AG13" (LR44) batteries.

REQUIRED TOOL:
PHILLIPS SCREWDRIVER
(NOT INCLUDED).

1,5V x 3
"AG13" (LR44)

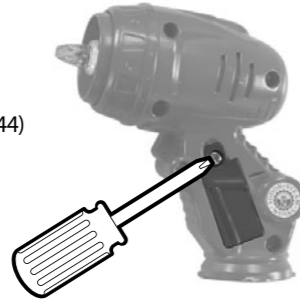

BATTERY SAFETY INFORMATION

In exceptional circumstances batteries may leak fluids that can cause a chemical burn injury or ruin your product. To avoid battery leakage:

- Non-rechargeable batteries are not to be recharged.
- Rechargeable batteries are to be removed from the product before being charged.
- Rechargeable batteries are only to be charged under adult supervision.
- Do not mix alkaline, standard (carbon-zinc), or rechargeable (nickel-cadmium) batteries.
- Do not mix old and new batteries.
- Only batteries of the same or equivalent type as recommended are to be used.
- Batteries are to be inserted with the correct polarity.
- Exhausted batteries are to be removed from the product.
- The supply terminals are not to be short-circuited.
- Dispose of battery(ies) safely.
- Do not dispose of this product in a fire. The batteries inside may explode or leak.

FCC STATEMENT (UNITED STATES ONLY)

This equipment has been tested and found to comply with the limits for a Class B digital device, pursuant to Part 15 of the FCC rules. These limits are designed to provide reasonable protection against harmful interference in a residential installation. This equipment generates uses and can radiate radio frequency energy and, if not installed and used in accordance with the instructions, may cause harmful interference to radio communications. However, there is no guarantee that interference will not occur in a particular installation. If this equipment does cause harmful interference to radio or television reception, which can be determined by turning the equipment off and on, the user is encouraged to try to correct the interference by one or more of the following measures:

- Reorient or relocate the receiving antenna.
- Increase the separation between the equipment and receiver.
- Consult the dealer or an experienced radio/TV technician for help.

NOTE: Changes or modifications not expressly approved by the manufacturer responsible for compliance could void the user's authority to operate the equipment. This device complies with Part 15 of the FCC Rules. Operation is subject to the following two conditions: (1) This device may not cause harmful interference, and (2) this device must accept any interference received, including interference that may cause undesired operation.

CAN ICES-3 (B)/NMB-3 (B)

Operation is subject to the following two conditions: (1) this device may not cause interference, and (2) this device must accept any interference, including interference that may cause undesired operation of the device.

L'utilisation de ce dispositif est autorisée seulement aux conditions suivantes : (1) il ne doit pas produire de brouillage et (2) il doit pouvoir tolérer tout brouillage radioélectrique reçu, même si ce brouillage est susceptible de compromettre son fonctionnement.



Protect the environment by not disposing of this product with household waste (2012/19/EU). Check your local authority for recycling advice and facilities.



STEAMWORKS REPAIR STATION



Keep these instructions for future reference as they contain important information.

WHAT'S INCLUDED

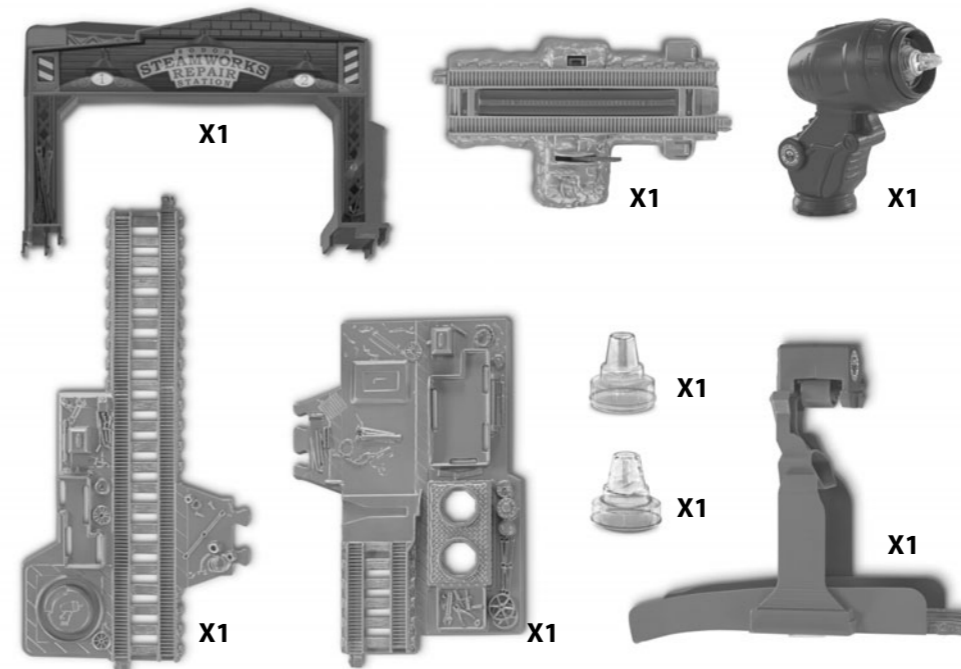

HELPFUL HINTS

★ **ONE-TIME SNAPS:** Assembly step that is marked with a star is "one-time snap". Once this part is put together, it cannot be taken apart.

Note: May not work with all engines.

ADULT ASSEMBLY REQUIRED.

No tools needed.



LABEL PLACEMENT

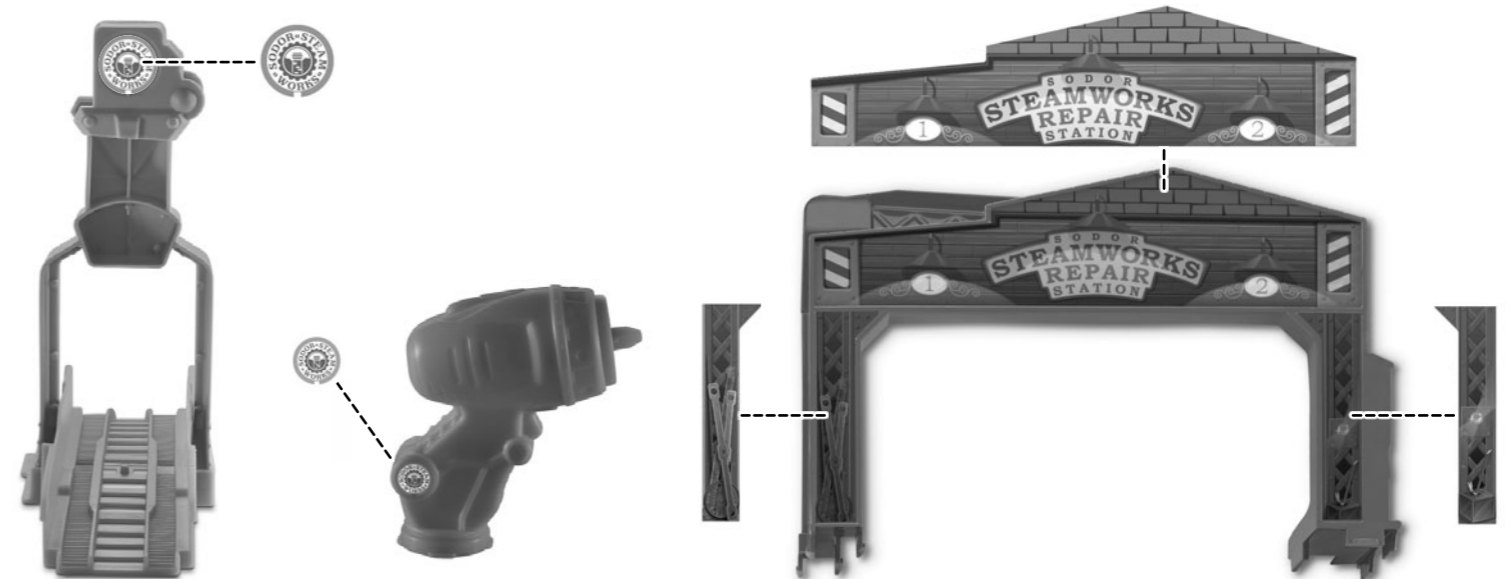

CONSUMER ASSISTANCE

1-800-432-5437 (US & Canada)
1300 135 312 (Australia)

service.fisher-price.com

Fisher-Price, Inc., 636 Girard Avenue, East Aurora, NY 14052.
Hearing-impaired consumers: 1-800-382-7470.

Outside the United States:

Canada: Mattel Canada Inc., 6155 Freemont Blvd.,
Mississauga, Ontario L5R 3W2; www.service.mattel.com.

Great Britain: Mattel UK Ltd, Vanwall Business Park,
Maidenhead SL6 4UB. Helpline: 01628 500303.
www.service.mattel.com/uk

Mattel Europa B.V., Gonde 1, 1186 MJ Amstelveen, Nederland.

Australia: Mattel Australia Pty. Ltd., 658 Church Street,
Locked Bag #870, Richmond, Victoria 3121 Australia.

New Zealand: 16-18 William Pickering Drive,
Albany 1331, Auckland.

Thomas the Tank Engine & Friends™



CREATED BY BRITT ALLCROFT

Based on the Railway Series by The Reverend W Awdry.
©2016 Gullane (Thomas) Limited. Thomas the Tank Engine & Friends and
Thomas & Friends are trademarks of Gullane (Thomas) Limited.
©2016 HIT Entertainment Limited. HIT and the HIT logo are trademarks of
HIT Entertainment Limited.

©2016 Mattel. All Rights Reserved. ® and ™ designate U.S. trademarks of Mattel,
except as noted. **PRINTED IN CHINA.**
Mattel East Asia Ltd., Room 503-09, North Tower, World Finance Centre, Harbour City,
Tsimshatsui, HK, China. Tel.: (852) 3185-6500.

DFM70
DFM70-0970
1100861987-DOM

Fisher-Price®

Item No : DFM70-0970 / 1100861987-DOM
Blank Size : A3
Paper : Recycle Paper, 70 gsm
Color : Black
Date : Dec, 31, 2015 (Lily Liang)

Folding method:

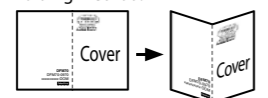

ASSEMBLY

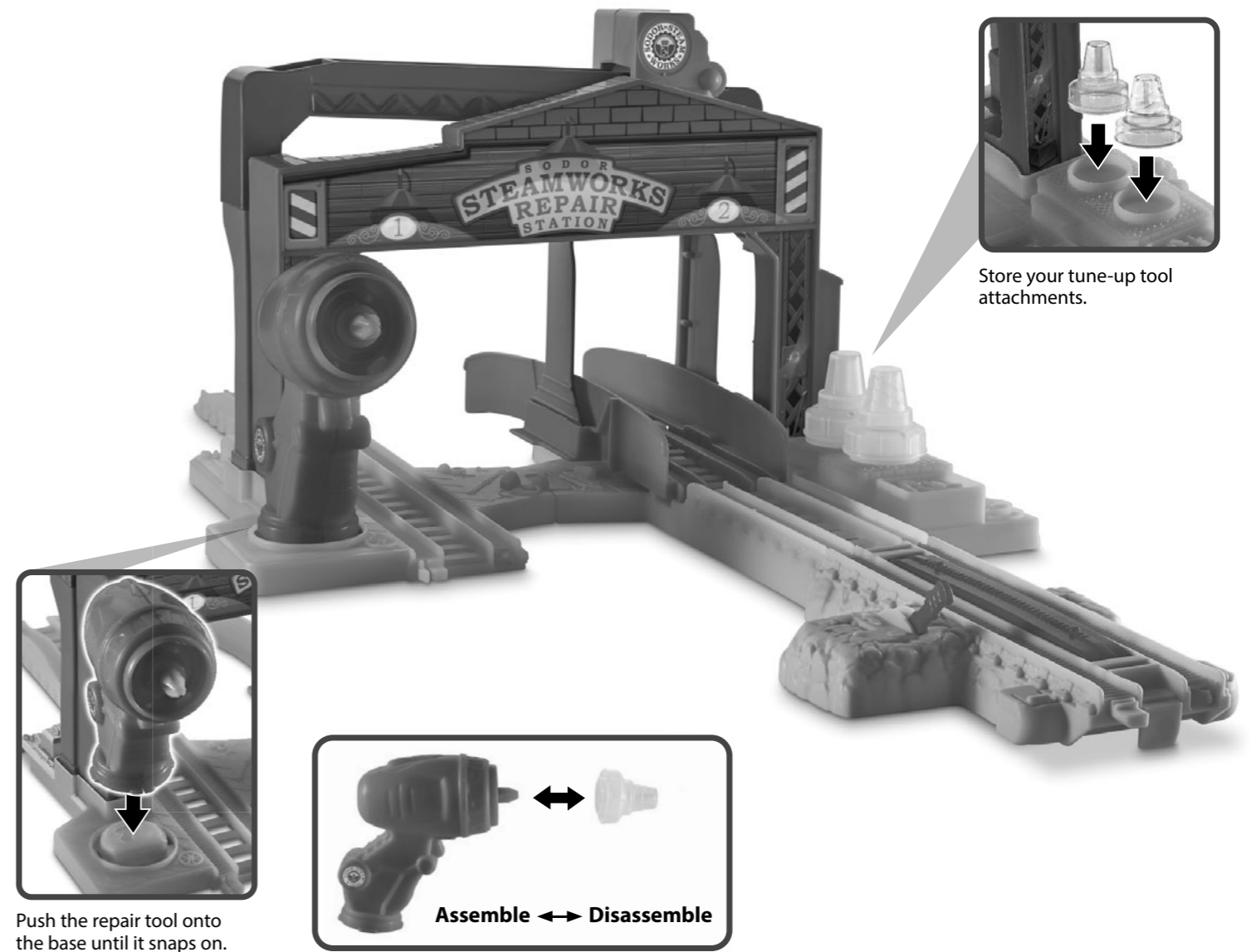
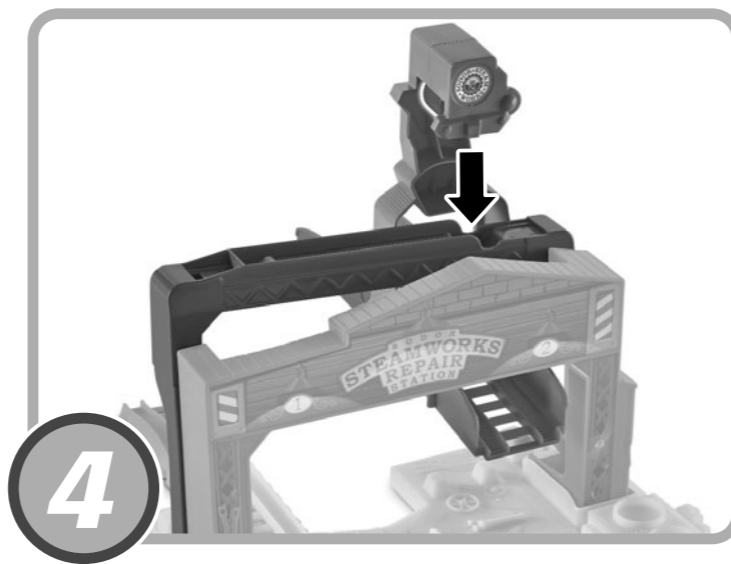
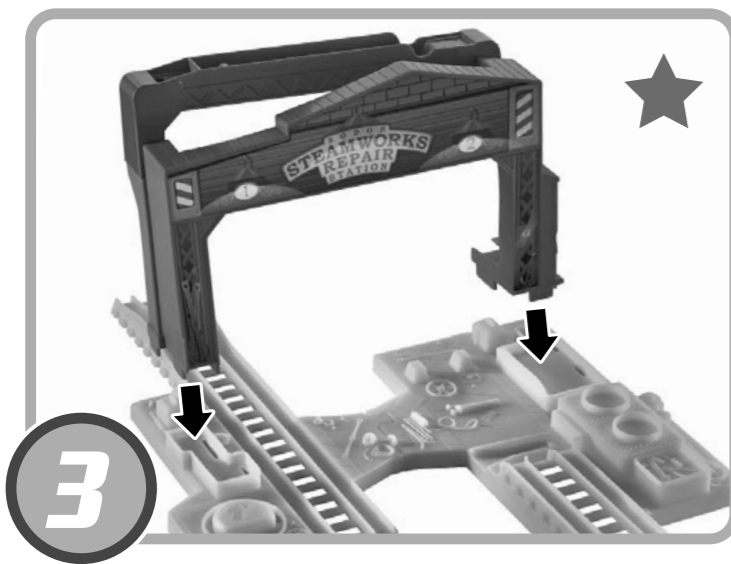
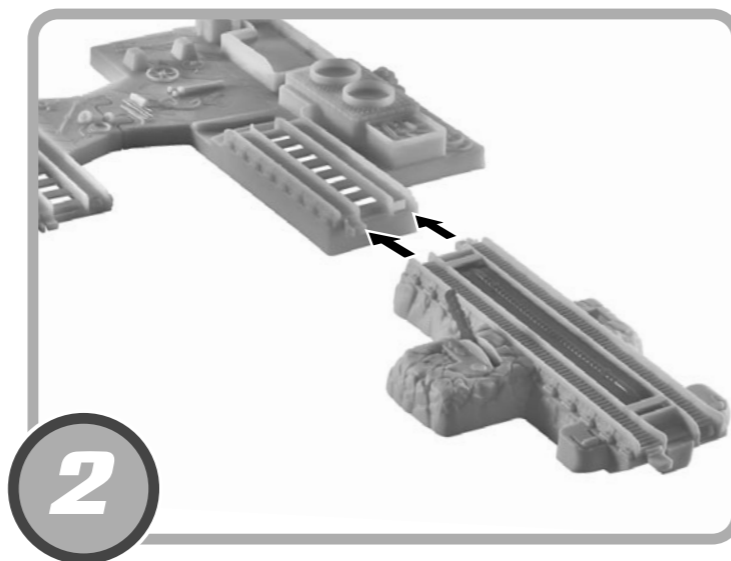
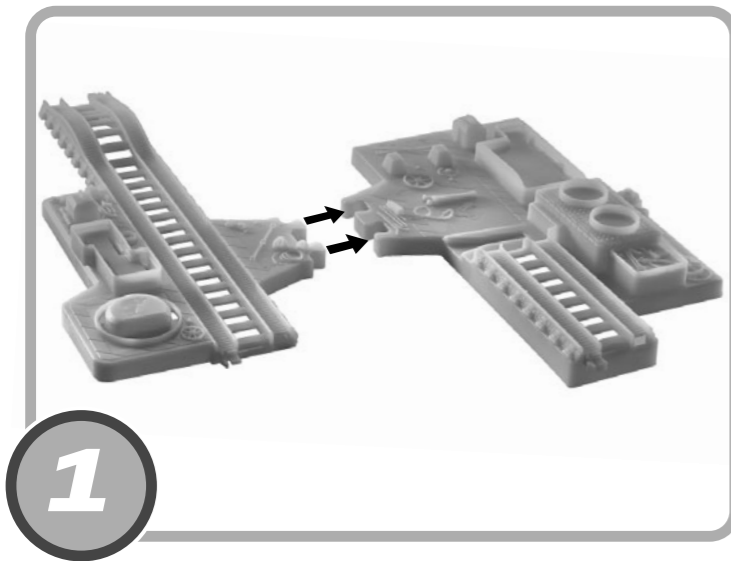

HOW TO PLAY

(* Thomas engine sold separately and subject to availability.)

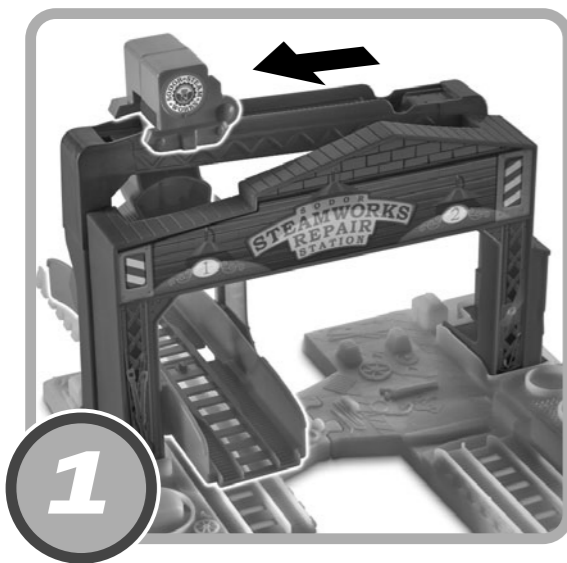

1 Set the engine lift platform.

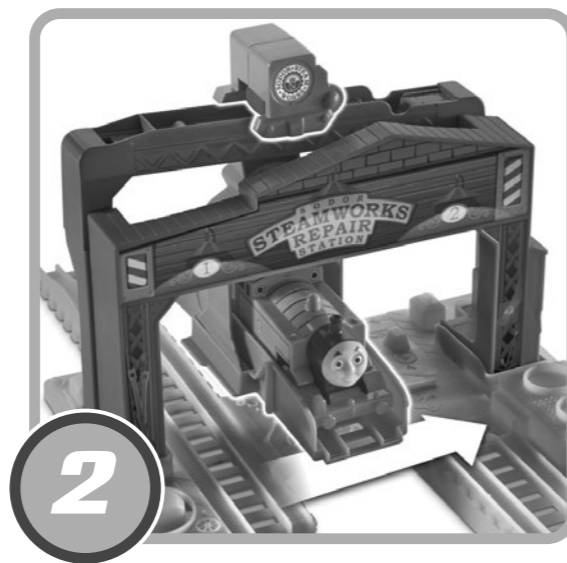

2 When the engine enters the Sodor Steamworks Repair Station, he is lifted and shifted to the other track!

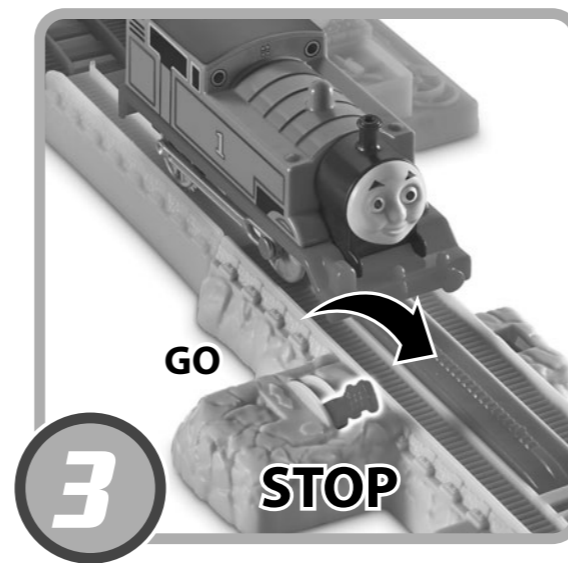

3 Use the stop-track to stop the engine.

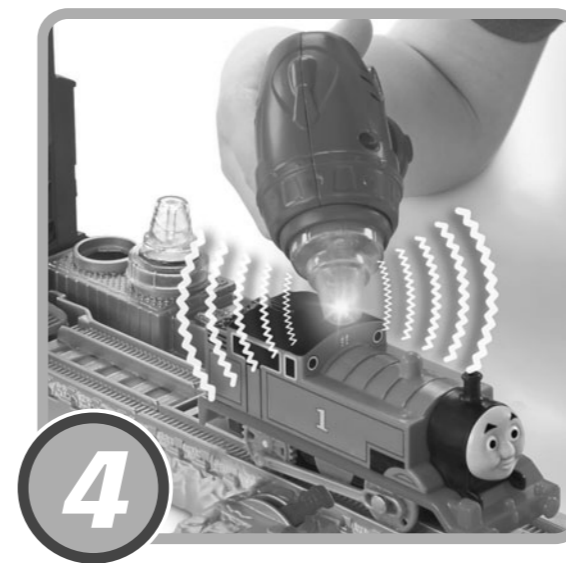

4 Use the tune-up tool to "repair" your engine. Choose different attachments for different colored lights and sound effects. Press the tip to activate.

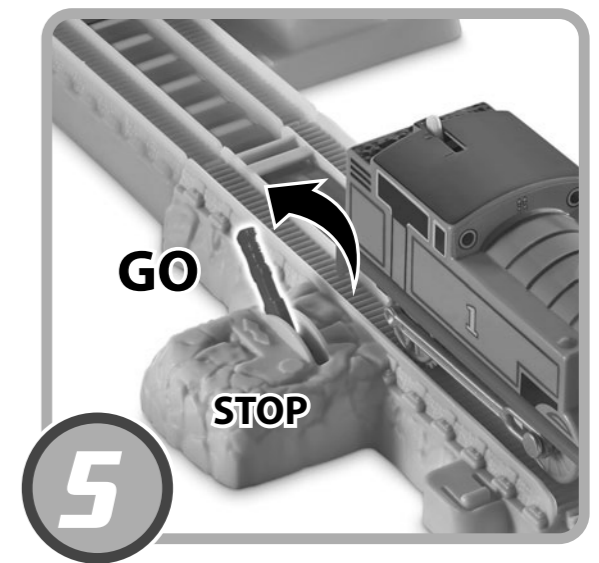

5 Flip the switch and let the engine go.