



Owner's Manual with Assembly Instructions

For Model G5107

Lightning Rac
PAGE



Product features may vary from the picture above.
Protective equipment not included.

Please read this manual and save it with your original sales receipt.

Tools needed for assembly: Adjustable Wrench, Pliers, Phillips Screwdriver, Safety Scissors (all not included), and Allen Wrench (included).

Use only with a Power Wheels® 12 Volt Lead-Acid Rechargeable Battery and a Power Wheels® 12 Volt Charger with Type "12V" Connector (both included).

Fisher-Price, Power Wheels and Power Wheels by Fisher-Price are U.S. trademarks of Mattel, Inc.

Table of Contents

A	Important Information	.2
B	Warnings and Cautions	.3
C	Parts	.5
D	Battery Charging	.6
E	Assembly	.8
F	Adjusting the Brake	.10
G	Label Decoration	.12
H	Battery Installation	.13
I	Battery Care and Disposal	.14
J	Rules for Safe Riding	.15
K	How to Operate Your Scooter	.16
L	Caring for Your Scooter	.18
M	Checklist	.19
N	Problems and Solutions Guide	.20
O	Limited Warranty	.23
P	FCC Statement	.23

A

Important Information

- Your new scooter requires adult assembly. Please set aside at least 20 minutes for assembly.
- You must charge your battery for 18 - 30 hours **before you use your scooter for the first time.** We recommend that you start charging your battery before beginning assembly. Please see Battery Charging beginning on page 6 for detailed instructions.
- Read this manual carefully for important safety information and operating instructions before using your scooter. Keep these instructions for future reference as they contain important information.
- This product is meant for outdoor use only, private property. It should not be used on streets, alleys or other public thoroughfares.
- Use this scooter **ONLY** outdoors. Most interior flooring can be damaged by riding this scooter indoors. Fisher-Price® will not be responsible for damage to floors if the scooter is used indoors.
- Your child must have experience and skill at riding a two wheel bicycle without training wheels before using this scooter.
- This scooter is designed for use on asphalt, grass or other hard surfaces; on generally level terrain; by children 6 years of age and older who can ride a two-wheeler without training wheels or any other assistance.
- Your child should not wear open-toe shoes.
- Keep loose laces and pant legs away from the wheels.
- Choose areas for riding that are free of obstacles, and avoid wet or uneven surfaces.
- To prevent damaging the motor, belt and pulleys, do not tow anything behind the scooter or overload it. Do not exceed the maximum weight capacity of 150 lb. (68 kg).
- To prevent damage, do not use the scooter on wet surfaces or in wet weather, and never immerse any part of this product. Moisture can damage switches and drive components.
- If you have any questions about your Power Wheels® scooter, please call our toll-free service lines at **1-800-348-0751** from 8 AM to 6 PM (EST) Monday through Friday. Trained customer service representatives are available to take your call in English or French. Habla Español? Si usted tiene alguna pregunta ó necesita asistencia llame gratis **1-800-348-0755** para los Estados Unidos. Tenemos representantes que hablan español para atender su llamada.
- For your convenience, Power Wheels® maintains an Authorized Service Center Network with more than 400 authorized service centers nationwide. Our authorized service centers will repair or replace parts under warranty at no extra charge, and can perform non-warranty repairs for a minimal charge. To find the authorized service center nearest you, please visit us on-line at **www.powerwheels.com** or call **1-800-348-0751**.
- If you would like to register your vehicle, please visit us on-line at **www.powerwheels.com**.
- For best performance, use only a Power Wheels® 12 volt battery. Please contact your local Power Wheels® Authorized Service Center for a replacement battery. To find the authorized service center nearest you, please visit us on-line at **www.powerwheels.com** or call **1-800-348-0751**.

ELECTRICAL HAZARD**WARNING**

- Battery can fall out and injure a child if vehicle tips over. Always use battery clamp (footboard).
- **PREVENT FIRE**
 - Never modify the electrical system. Alterations could cause a fire resulting in serious injury and could also ruin the electrical system.
 - Use of the wrong type battery or charger could cause a fire or explosion resulting in serious injury.
 - Use of Power Wheels® components in products other than Power Wheels® vehicles could cause overheating, fire or explosion.
- The battery must be handled by adults only. The battery is heavy and contains sulfuric acid (electrolyte). Dropping the battery could result in serious injury.
- Never allow children to charge the battery. Battery charging must be done by adults only. A child could be injured by the electricity involved in charging the battery.
- Never lift or carry the battery by the wires or connector. This can damage the battery and possibly cause a fire resulting in serious injury. Lift and carry the battery by the strap only.
- Read the safety instructions on the battery.
- Examine the battery, charger and their connectors for excessive wear or damage each time you charge the battery. If damage or excessive wear is detected, do not use the charger or the battery until you have replaced the worn or damaged part.
- **HOT** motor. Handle carefully.

Warnings and Cautions

RIDING RULES



WARNING

Direct Adult Supervision Required

- To prevent injury, keep away from cars and streets, steep inclines, steps, swimming pools and other bodies of water.
- Protective equipment should be worn. Use helmet, knee and elbow pads (not included).
- Never ride at night.
- Always wear shoes.
- Never allow more than (1) one rider.

TIRE INFLATION



WARNING

To prevent tire explosion:

- Never inflate above 30 psi.
- Use only a hand pump to prevent over-inflation.



CAUTION

- In the unassembled state, this package contains small parts. Adult assembly is required.
- Use the charger in dry locations only.

C

Parts

- If you experience a problem with this product, or are missing a part, please call us at **1-800-348-0751**, rather than return this product to the store.
- Please identify all parts before assembly and save all packaging material until assembly is complete to ensure that no parts are discarded.
- Metal parts have been coated with a lubricant to protect them during shipment. Wipe all metal parts with a paper towel to remove any excess lubricant.

Part Not Shown: Label Sheet.

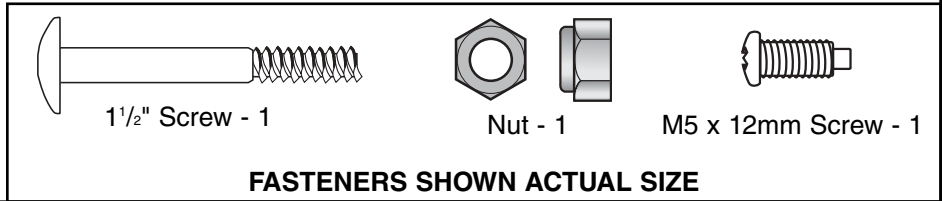
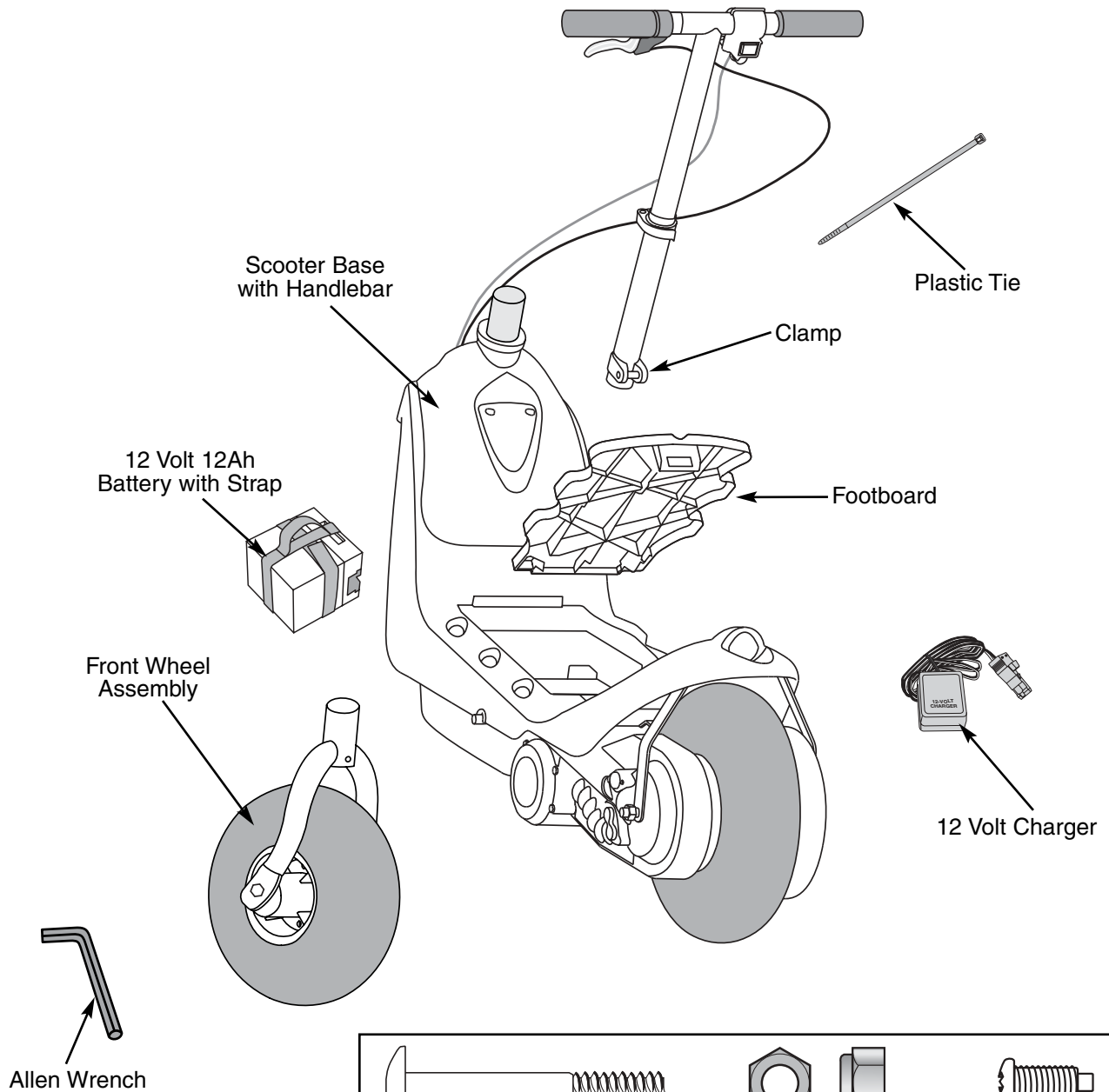

ELECTRICAL HAZARD **WARNING**

- Battery can fall out and injure a child if scooter tips over. Always use battery clamp (footboard).
- **PREVENT FIRE**
 - Never modify the electrical system. Alterations could cause a fire resulting in serious injury and could also ruin the electrical system.
 - Use of the wrong type battery or charger could cause a fire or explosion resulting in serious injury.
 - Use of Power Wheels® components in products other than Power Wheels® vehicles could cause overheating, fire or explosion.
- The battery must be handled by adults only. The battery is heavy and contains sulfuric acid (electrolyte). Dropping the battery could result in serious injury.
- Never allow children to charge the battery. Battery charging must be done by adults only. A child could be injured by the electricity involved in charging the battery.
- Never lift or carry the battery by the wires or connector. This can damage the battery and possibly cause a fire resulting in serious injury. Lift and carry the battery by the strap only.
- Read the safety instructions on the battery.
- Examine the battery, charger and their connectors for excessive wear or damage each time you charge the battery. If damage or excessive wear is detected, do not use the charger or the battery until you have replaced the worn or damaged part.

 **CAUTION**

Use the charger in dry locations only.

About Thermal Fuses

Your Power Wheels® 12 volt battery is equipped with a built-in thermal fuse. The thermal fuse is a self-resetting safety device which automatically “trips” and shuts down operation of the scooter if the scooter is overloaded or the driving conditions too severe. Once a fuse has “tripped”, it will automatically reset itself after approximately 25 seconds and allow the scooter to resume normal operation. To avoid repeated automatic shutdowns, do not overload the scooter by exceeding the 150 lb. maximum weight capacity or by towing anything behind the scooter. Avoid severe driving conditions, such as driving up steep slopes or running into fixed objects, which can cause the wheels to stop spinning while power is still being supplied to the motors.

If a thermal fuse in a battery continually trips under normal driving conditions, please contact your local Power Wheels® authorized service center. For the location of the authorized service center nearest to you, please visit us on-line at www.powerwheels.com or call **1-800-348-0751**.

IMPORTANT!

- **Your new battery must be charged for at least 18 hours before you use it in your scooter for the first time.** We recommend that you start charging your battery before beginning assembly of your new scooter.
- The battery must be upright while charging.
- The charger is not a toy.
- Do not short circuit the battery.
- Before charging the battery, examine the battery case for cracks and other damage which may cause sulfuric acid (electrolyte) to leak during the charging process. If damage is detected, do not charge the battery or use it in your scooter. Battery acid is very corrosive and can cause severe damage to surfaces it contacts.
- Do not charge the battery on a surface (such as kitchen countertops) which could be damaged by the acid contained inside the battery. Take precautions to protect the surface on which you charge your battery.
- Use only a Power Wheels® 12 volt charger with type “12V” connector (120 VAC 60 Hz 28W with an output of 12 VDC 1200mA) to charge your Power Wheels® rechargeable 12 volt battery.
- For best performance, use only a Power Wheels® 12 volt battery. Please contact your local Power Wheels® authorized service center for a replacement battery. To find the authorized service center nearest you, please visit us on-line at www.powerwheels.com or call **1-800-348-0751**.
- If your battery is old and will not accept a charge, do not leave it in the scooter. Always remove a dead battery from the scooter.

Battery Charging

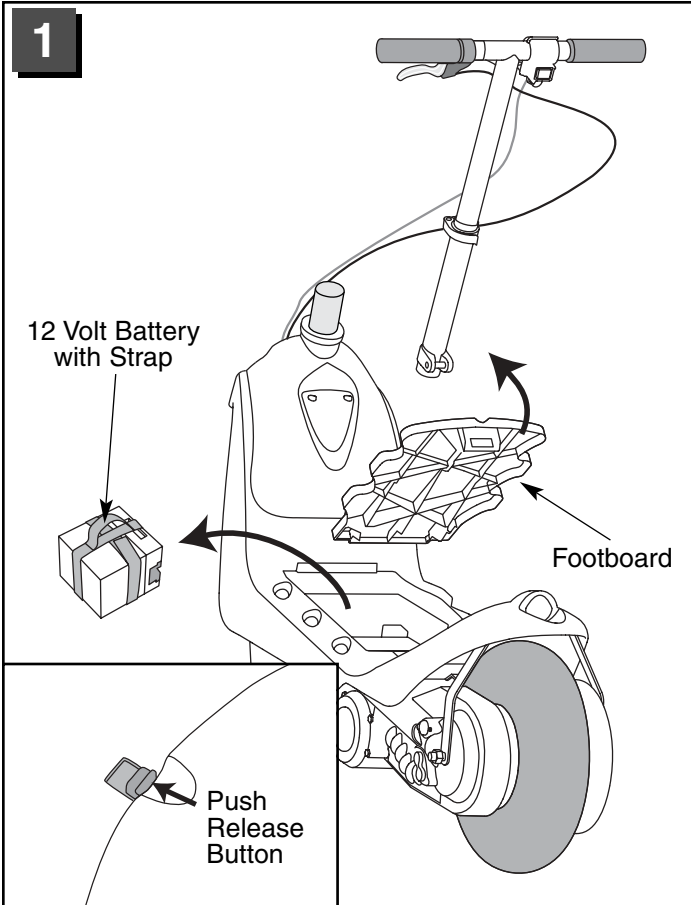

- While pushing the release button on the scooter floor, lift the footboard from the scooter.
- Grasp the battery strap and lift to remove the 12 volt battery from the battery compartment.

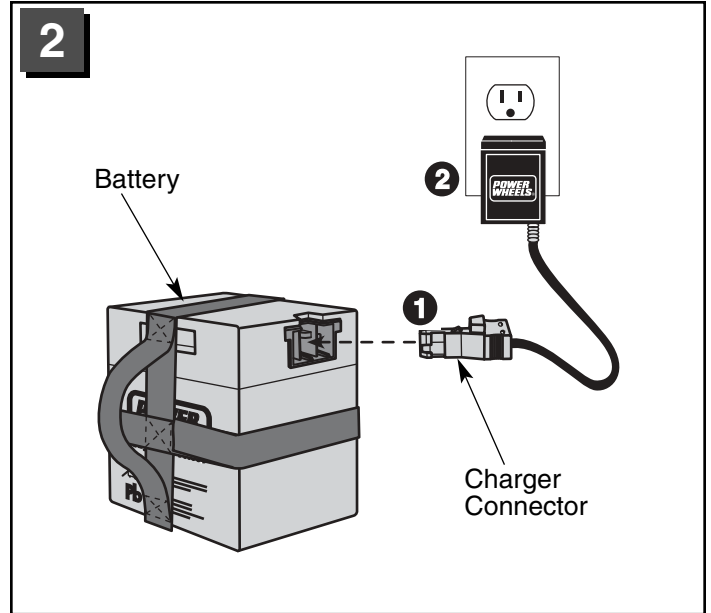

- Plug the charger connector into the battery **1**.
- Plug the charger into a standard 120 volt wall outlet **2**.

Note: If power flow to the wall outlet is controlled by a switch, make sure the switch is "ON".

- Before first-time use, charge the battery for **at least 18 hours**. Never charge the battery longer than 30 hours.
- Recharge the battery for at least 14 hours after each use of your vehicle. Do not charge the battery longer than 30 hours.
- Once the battery is charged, pull firmly on the charger connector to disconnect it from the battery. Unplug the charger from the wall outlet. The battery is now ready to be installed in your scooter. Please see the Battery Installation section on page 13 for detailed instructions on installing your battery.

⚠ WARNING

Children can be harmed by small parts, sharp edges and sharp points in the scooter's unassembled state, or by electrical items. Care should be taken in unpacking and assembly of the scooter. Children should not handle parts, including the battery, or help in assembly of the scooter.

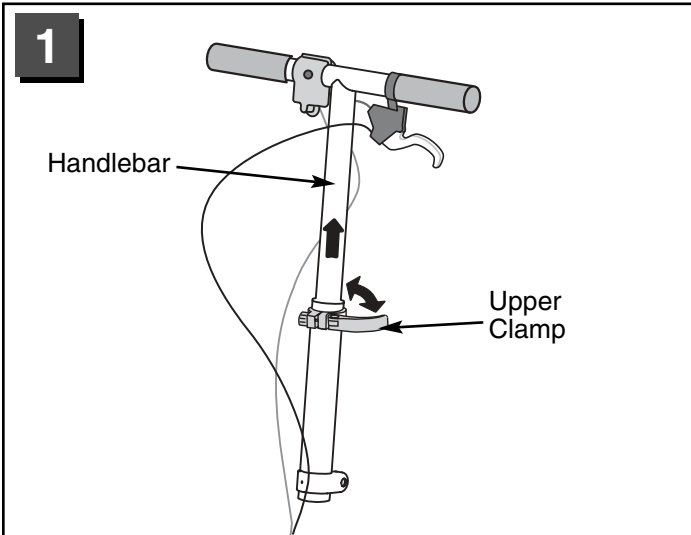

- Open the upper clamp on the handlebar.
- Lift the handlebar to its highest position.
- Close the upper clamp on the handlebar.

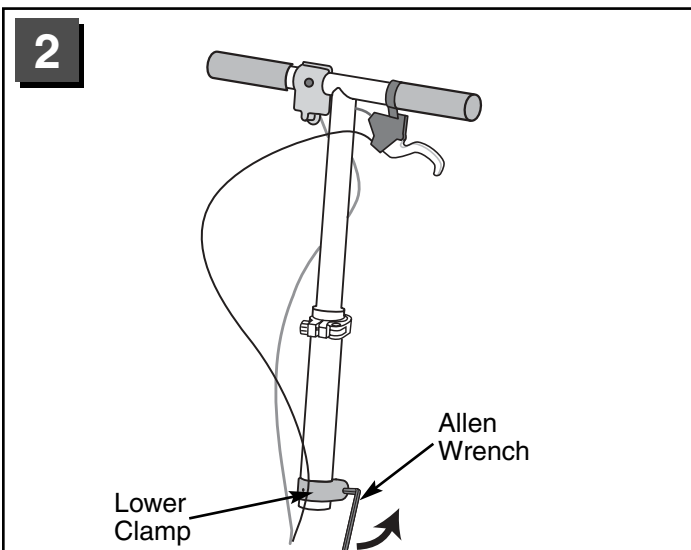

- Loosen the nut in the lower clamp on the handlebar with the Allen wrench.

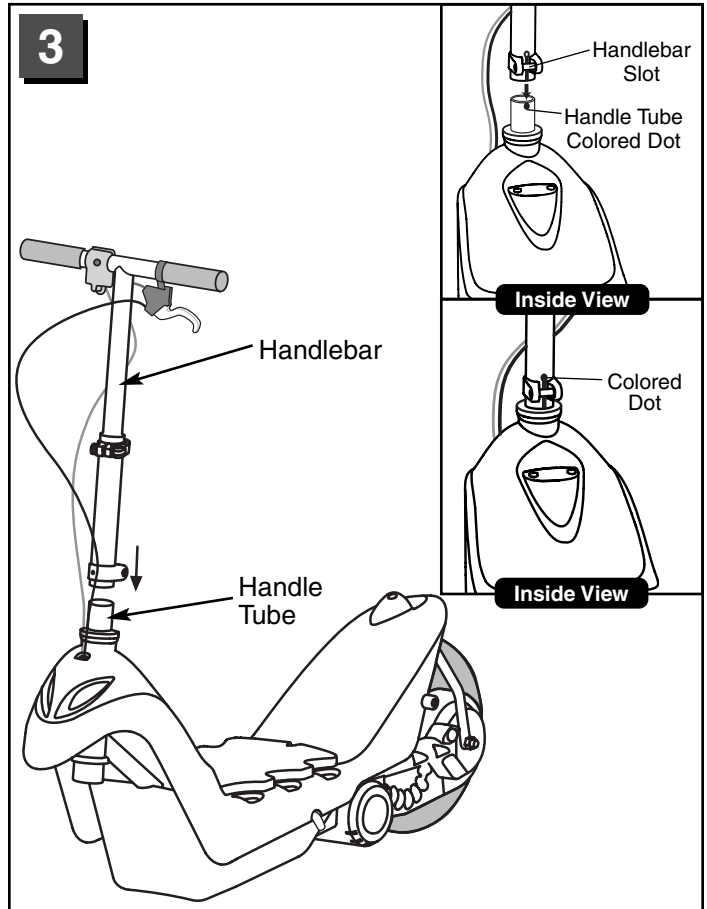

- Note the location of the colored dot on the handle tube.
- Fit the handlebar onto the handle tube.

IMPORTANT! Make sure the colored dot on the handle tube is **visible** through the slot in the handlebar.

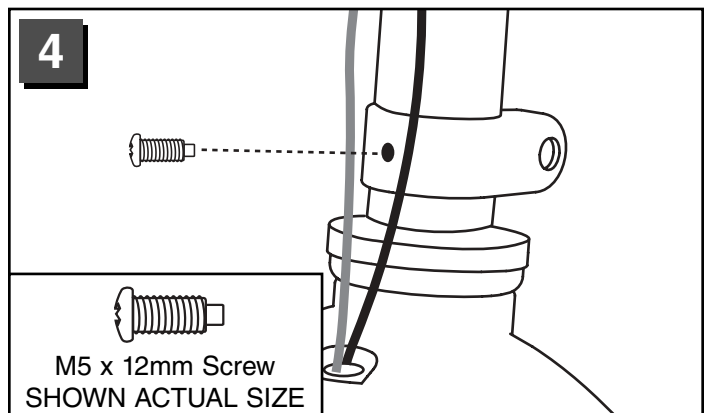

- Align the hole in the front of the lower clamp, handle tube and handle bar.
- Insert the M5 x 12mm screw through the hole in the clamp and into the handlebar and handle tube. Tighten the screw with a Phillips screwdriver.

Assembly

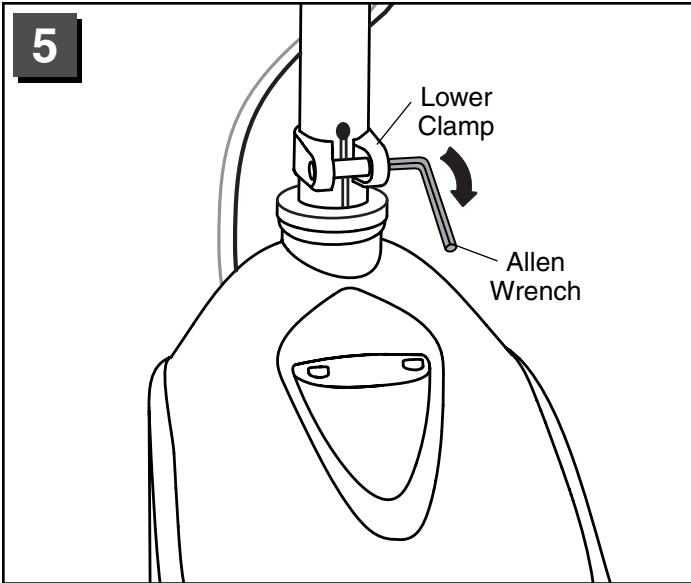

- Tighten the nut in the lower clamp with the Allen wrench. Do not over-tighten.

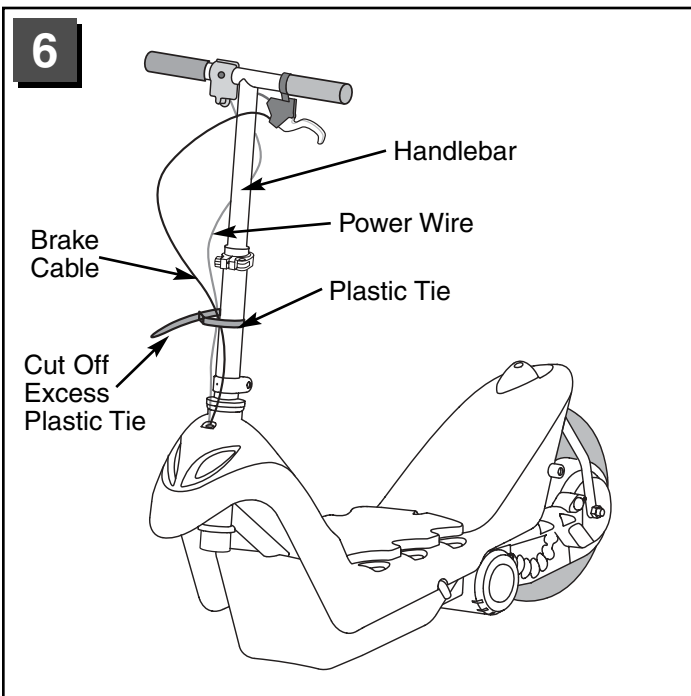

- Make sure the handlebar is in its highest position.
Hint: Please see Assembly Step 1 on page 8.
- Wrap the plastic tie around the brake cable, power wire and the handlebar.
- Insert the flat end of the plastic tie into the opening in the square end of the plastic tie. Pull the flat end of the plastic tie with pliers to be sure it is tight around the handlebar.
- Using safety scissors, cut off the excess plastic tie. Throw the excess plastic tie away.

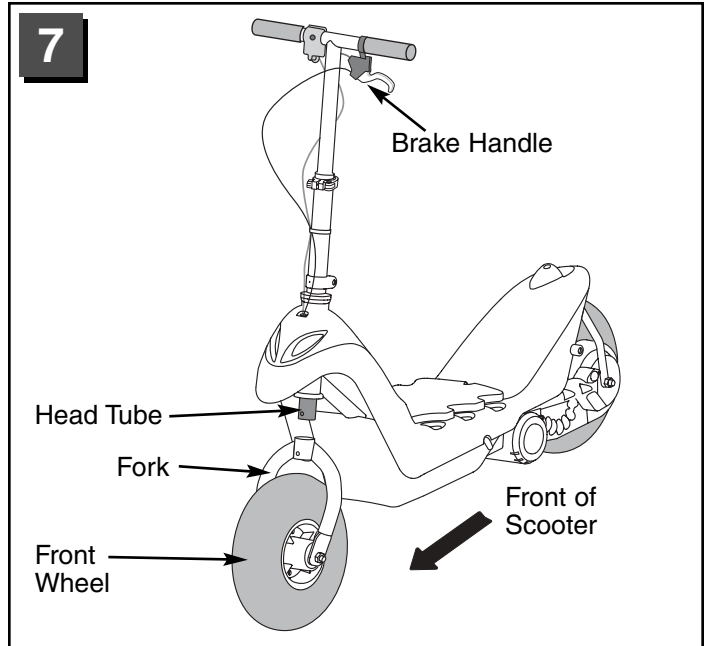

- Adjust the handlebar so that the brake handle is towards the front of the scooter.
- Fit the front wheel onto the head tube so that the **fork bends toward the front** of the scooter.

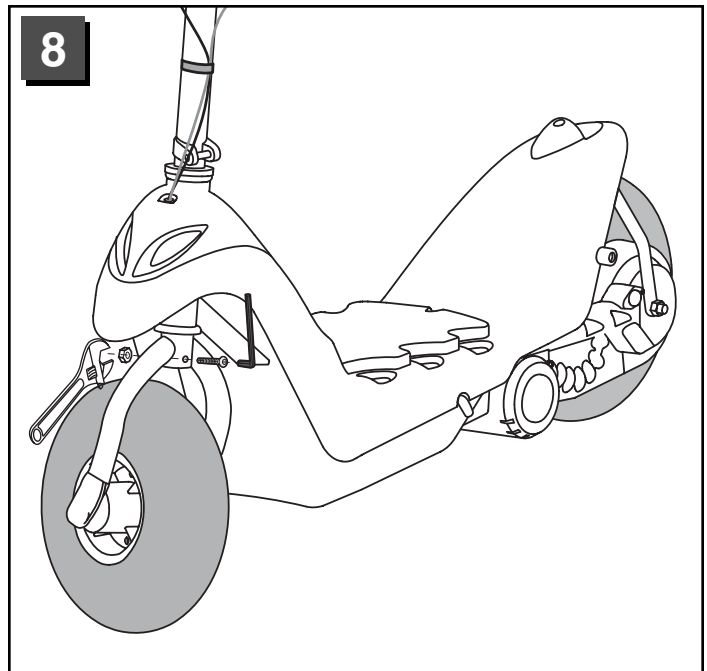

- Insert a bolt through one side of the fork, head tube and out through the other side of the fork.
- Turn the front wheel so that it is sideways, as shown.
- Attach the nut to the bolt. While holding the nut with an adjustable wrench, tighten the bolt with the Allen wrench. Do not over-tighten.

IMPORTANT! Assembly is now complete, but you **must adjust the brake before first-time use**. Please proceed to the next section *Adjusting the Brakes*, page 10.

F

Adjusting the Brake

IMPORTANT! Check to be sure the brake is adjusted properly and is tight. Please follow these instructions carefully before you use this scooter.

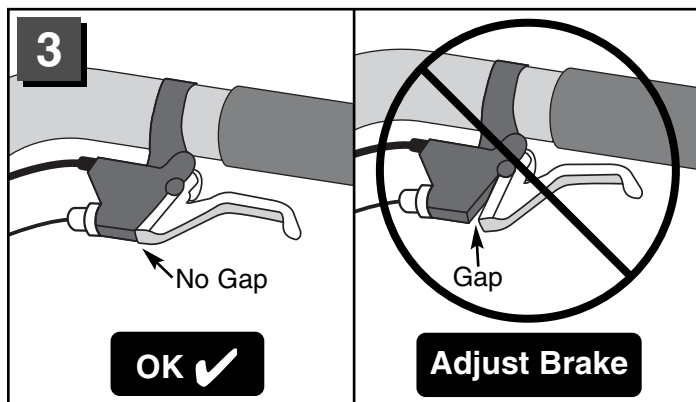
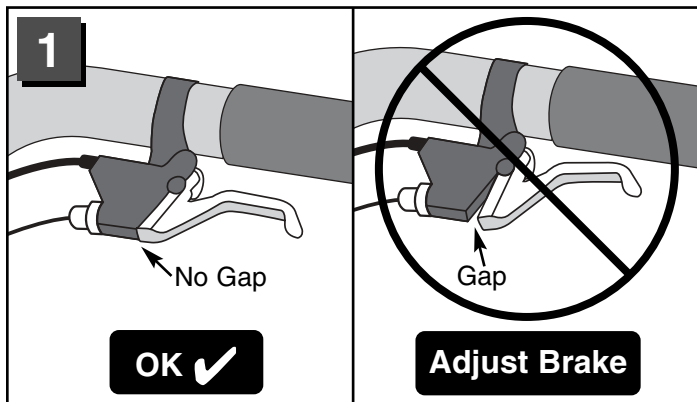

- From the front of the handlebar, examine the brake handle and the brake base.
 - **If there is NO gap** between the brake base and the brake handle, your brake is properly adjusted. Please proceed to the label decoration section on page 12.
 - **If there IS a gap** between the brake base and the brake handle, your brake **needs to be adjusted** and tightened. Please go on to step 2 in this section.

- Now, from the front of the handlebar, examine the brake handle again.
 - **If there is NO gap** between the brake base and the brake handle your brake is properly adjusted. Please proceed to the label decoration section on page 12.
 - If you cannot eliminate the gap or if the brake adjustment knob unthreads from the brake base, proceed to step 4.

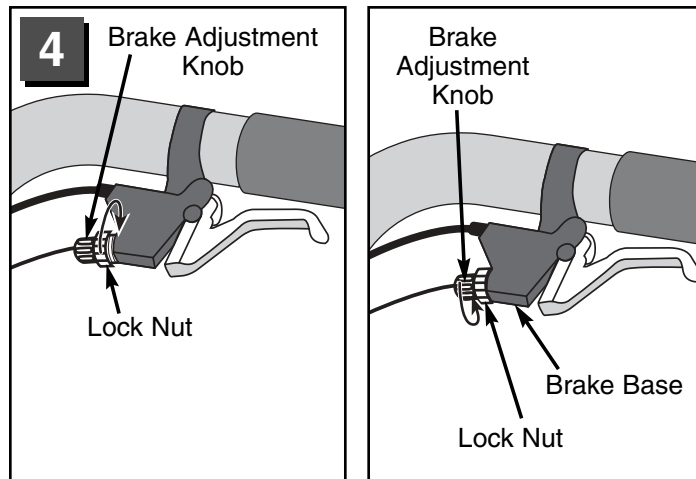
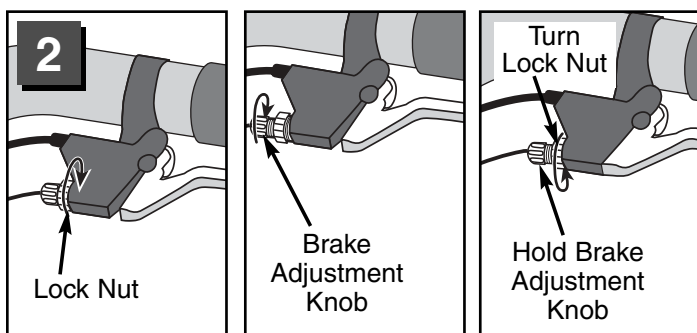

- Turn the lock nut clockwise a few times to loosen it.
- Turn the brake adjustment knob clockwise a few times to tighten the brake and close the gap between the brake base and brake handle.
- When the gap is closed, hold the brake adjustment knob in position and turn the lock nut counter-clockwise tight against the brake base to secure the adjustment.

- Turn the lock nut clockwise until it stops against the brake adjustment knob.
- Turn the brake adjustment knob counter-clockwise until the lock nut stops against the brake base.

Adjusting the Brakes

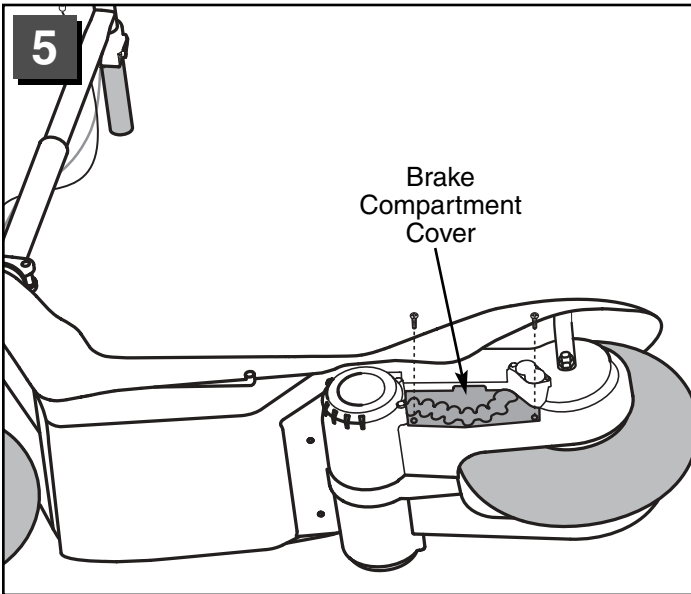

- Turn the scooter so that the side is upright.
- Loosen and remove the screws in the brake compartment cover.
- Remove the brake compartment cover.

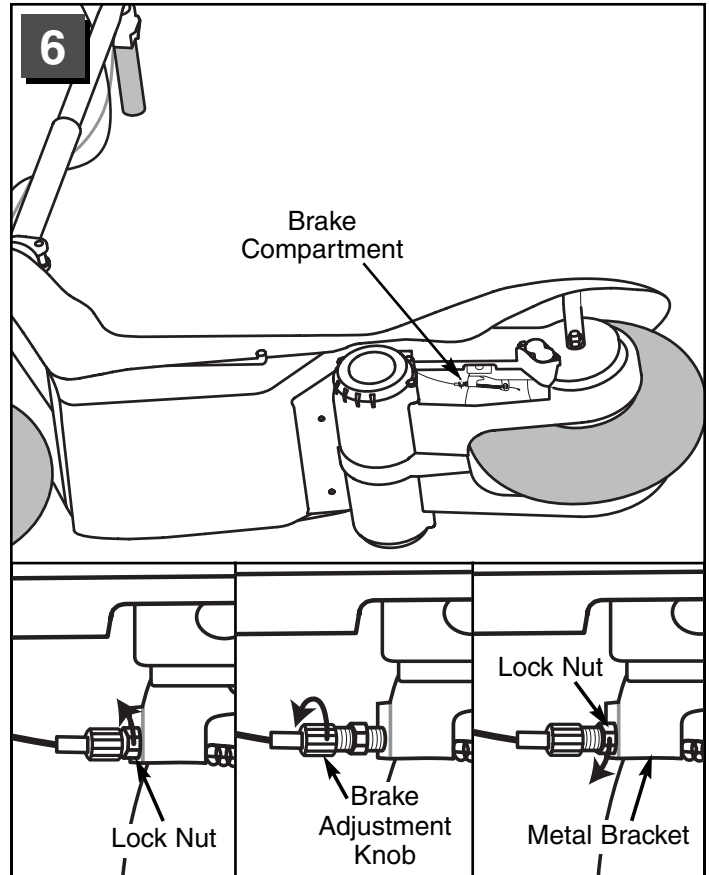

- Locate the brake compartment.
- Turn the lock nut counter-clockwise a few turns to loosen it.
- Turn the brake adjustment knob counter-clockwise a few turns to close the gap.
- Again, examine the brake handle to be sure there is no gap between the brake base and the brake handle. Re-tighten the brake adjustment knob if still needed.
- After you are satisfied that you have properly closed the gap between the brake base and the break handle, hold the brake adjustment knob in position and turn the lock nut clockwise until it stops against the metal bracket.
- Replace the brake compartment cover and the screws. Tighten the screws with a Phillips screwdriver. Do not over-tighten.

Hint: The placement of the brake handle is adjustable for your child's comfort. To adjust, loosen the screw on the back of the brake handle with the Allen wrench provided. Slide or rotate the handle to the desired location and re-tighten the screw with the Allen wrench.

G

Label Decoration

Proper label application will help to keep the labels looking their best! When applying labels, keep the following guidelines in mind:

- Wash your hands before applying the labels.
- Before applying the labels, wipe the surface of the scooter with a clean, dry cloth to remove any dust or oils.
- Place the labels exactly as shown in the illustrations.
- For best results, avoid repositioning a label once it has been applied to the scooter.
- **After applying a label, rub the label firmly with a clean, dry cloth to make sure the label is adhered to your scooter. Start at the center of a label, and smooth towards the outer edges to remove air bubbles.**

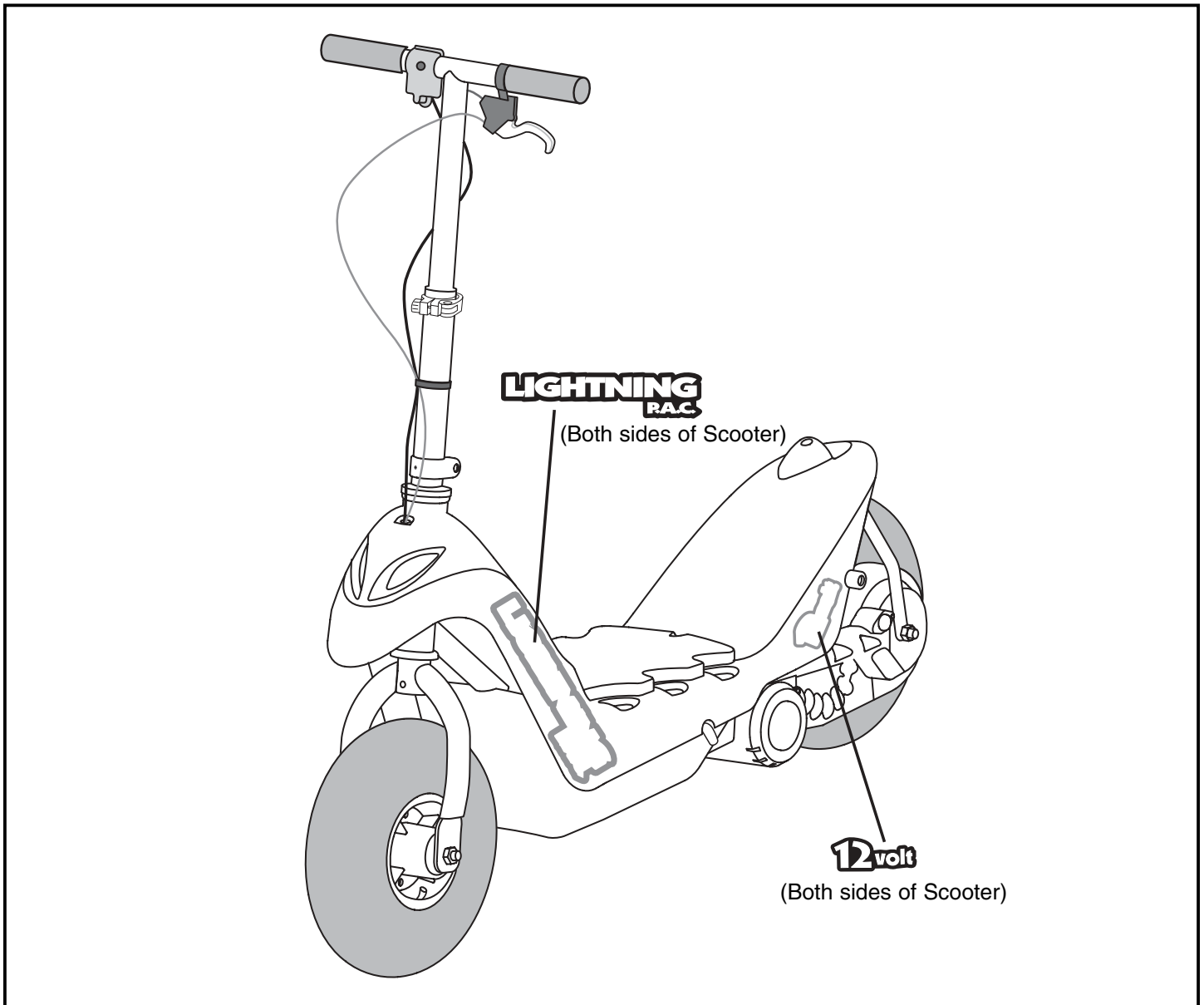

IMPORTANT! Use only a Power Wheels® 12 volt battery. Use of any other battery will damage your scooter. Make sure that you charge the battery for at least 18 hours using the enclosed Power Wheels® 12 volt charger before operating your scooter for the first time. Charge the battery for at least 14 hours after each use of the scooter. Never charge the battery longer than 30 hours. Failure to follow these instructions may damage your battery and will void your warranty.

For best performance, use only a Power Wheels® 12 volt battery. Please contact your local Power Wheels® Authorized Service Center for a replacement battery. To find the authorized service center nearest you, please visit us on-line at www.powerwheels.com or call 1-800-348-0751.

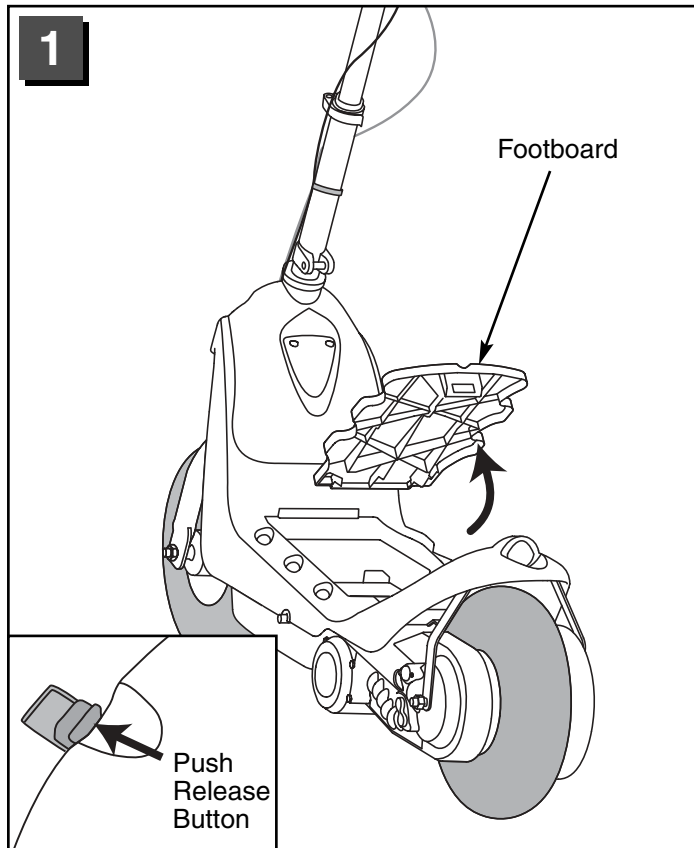

- While pushing the release button on the scooter floor, lift the footboard from the scooter.

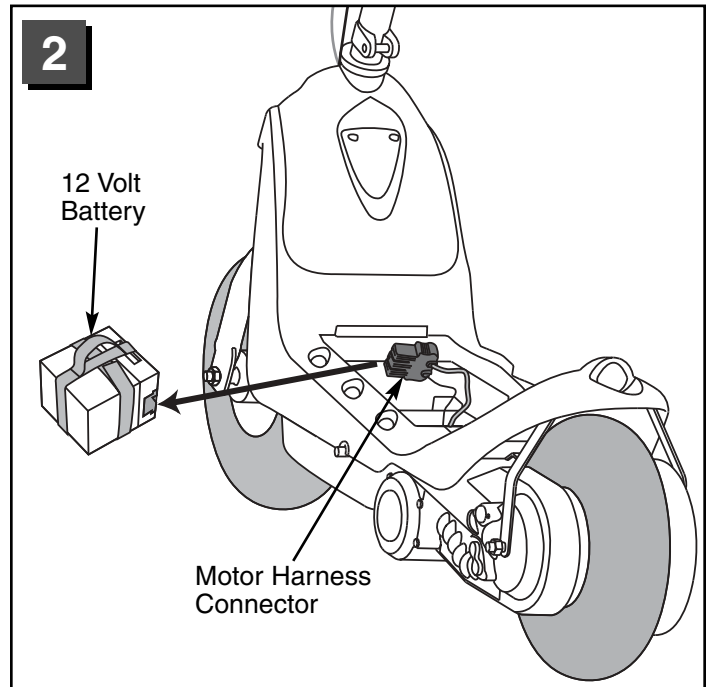

- Plug the motor harness connector into the battery socket. **Push firmly to make sure the motor harness connector is completely inserted into the battery.**

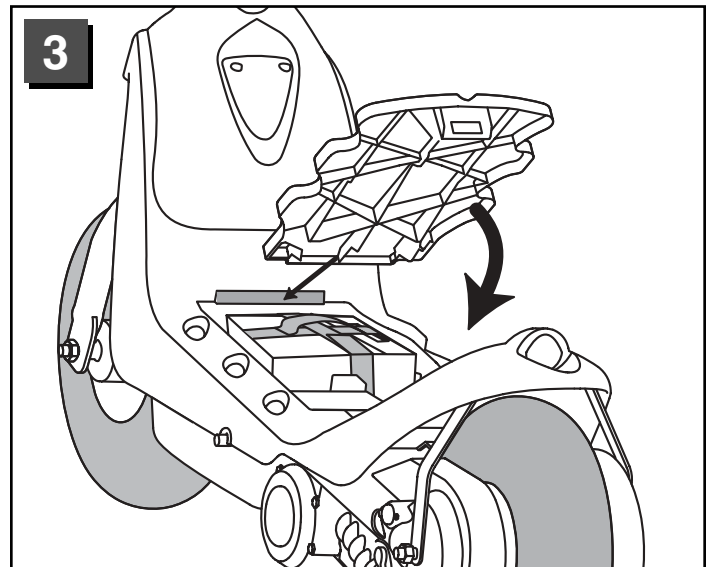

- Fit the battery into the battery compartment, as shown.
- At an angle, insert the front tab on the footboard into the slot in the scooter floor.
- Push down on the footboard to “snap” it into place.

Care

If a battery leak develops, avoid contact with the leaking acid and place the damaged battery in a plastic bag. See information on this page for proper disposal.

If acid comes in contact with skin or eyes, flush with cool water for at least 15 minutes and call a physician.

If acid is internally ingested, give water, milk of magnesia or egg whites immediately. Never give emetics or induce vomiting. Call a physician.

- Charge a new battery for at least 18 hours before first use. Never charge the battery longer than 30 hours. Overcharging or undercharging the battery may shorten battery life and decrease scooter running time.
- After the first charge, recharge the battery for at least 14 hours after each use. Never charge the battery longer than 30 hours. Charge the battery after each use, regardless of how long the scooter was used.
- The battery must be upright while charging.
- Do not allow the battery to run down completely before charging.
- Charge the battery before storing the scooter.
- Charge the battery at least once per month, even if the scooter has not been used.
- Leaving the battery in a discharged condition will ruin it.
- Always remove an exhausted battery from the scooter. Battery leakage and corrosion can damage the scooter.
- Do not store the battery on a surface (such as a kitchen countertop) which could be damaged by the acid contained inside the battery. Take precautions to protect the surface on which you store the battery.
- Do not store the battery in temperatures above 75° F or below -10° F.
- Prevent the battery from moving freely inside the battery compartment. Always use the battery clamp (footboard) to secure the battery in the battery compartment.
- Examine the battery, charger and its connector for excessive wear or damage each time you charge the battery. If damage is detected, do not use the charger or the battery until you have replaced the worn or damaged part.

Disposal



- Your Power Wheels® battery is a sealed lead-acid battery. It must be recycled or disposed of in an environmentally sound manner.
- Do not dispose of a lead-acid battery in your regular, household trash. The incineration, landfilling or mixing of sealed lead-acid batteries with household trash is prohibited by law in most areas.
- Do not dispose of a lead-acid battery in a fire. The battery may explode or leak.
- Return exhausted batteries to a federal or state approved lead-acid battery recycler, such as a Power Wheels® authorized service center, or a local seller of automotive batteries. For the authorized service center location nearest to you, please call **1-800-348-0751**. Contact your local waste management officials for other information regarding the environmentally sound collection, recycling and disposal of lead-acid batteries. If you live in the State of Florida or the State of Minnesota, it is prohibited by law for anyone to throw away lead-acid batteries in the municipal waste stream.

IMPORTANT! Please carefully read the owner's information in this manual and teach your child about proper scooter operation and rules for safe riding before allowing operation of this scooter.

RIDING RULES

WARNING

Direct Adult Supervision Required

- To prevent injury, keep away from cars and streets, steep inclines, steps, swimming pools and other bodies of water.
- Protective equipment should be worn. Use helmet, knee and elbow pads (not included).
- Never ride at night.
- Always wear shoes.
- Never allow more than (1) one rider.

Teach Safety Rules to Children

While children can quickly develop the skill necessary to ride this scooter, it is important to remember that their judgment skills are still very immature. Unsupervised riding by children can lead to serious injury. Before children use this scooter, an adult should carefully evaluate the riding area as well as the children's skill level and ability to ride this scooter safely. Children are not always able to recognize or anticipate hazards, even when they have been taught about them. **There is no acceptable substitute for direct adult supervision.**

Teach appropriate safety rules to your child before allowing operation of this scooter. These rules should also be reviewed with neighborhood children or other playmates who want to ride this scooter.

Riding Rules

Make sure children know and follow these rules for safe riding:

1. This product is meant for outdoor use only, private property. It should not be used on streets or other public thoroughfares.
2. Do not allow any child to ride the scooter in the street or near moving (motorized) vehicles.
3. Do not allow any child to ride near bodies of water (such as pools or creeks), obstructions (such as furniture, low tree limbs or play equipment), or drop-offs (such as stairs or decks).
4. Do not allow any child to ride the scooter in the dark. A child could encounter unexpected obstacles and have an accident. Operate the scooter only in the daytime or a well-lit area.
5. Do not allow your child to ride on sloped or inclined surfaces. **Restrict your child's riding to generally level ground ONLY!**
6. Do not allow your child to ride down or across a steep slope.
 - The scooter may gain unsafe speed.
 - The scooter may tilt and tip over.
 - The wheels could lose traction, causing the scooter to slip.
7. Do not allow your child to ride up steep inclines. The motor may stop and the scooter could roll backwards at an unsafe speed.
8. Never put anything near any moving parts. Rotating parts such as motor, belts, pulleys and wheels can snag fingers, hair, etc., causing serious injury. Do not allow operation of the scooter when it is on its side or in an upside-down position.
9. Do not operate the scooter near flammable vapors (gasoline, paint thinner, acetone, liquid wax, etc.). The scooter's electrical switches, like most electrical switches, emit an internal spark when first turned on or turned off. The presence of flammable liquids or vapors could cause an explosion or a fire. Keep all flammable products in tightly sealed containers and away from the scooter.
10. Do not allow a child to operate the scooter without direct adult supervision. To prevent unsupervised use of the scooter, disconnect the motor harness from the battery when the scooter is not in use.
11. The brake should be checked for proper function **before each use**. Check brake adjustment regularly (see page 10).

Adjust Handle Height

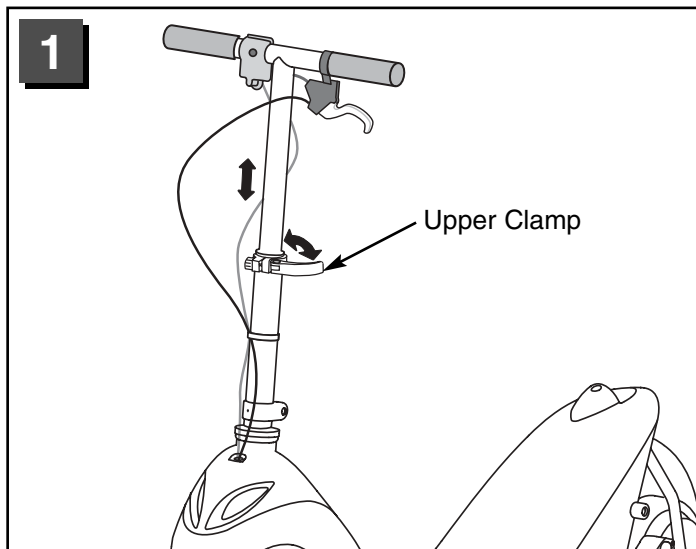

- Open the handlebar upper clamp to unlock the handlebar.
- Lift or lower the handlebar so that it is at a comfortable height for your child.
- Close the upper handlebar clamp to **lock** the handlebar in place.

IMPORTANT! If the handlebar clamp does not lock the handlebar in place, or, you cannot close the handlebar clamp to lock the handlebar in place, you may need to tighten or loosen the handlebar clamp. Fit the Allen wrench into the nut in the clamp and tighten or loosen as necessary. Be sure to close the handlebar clamp to **lock** the handlebar in place.

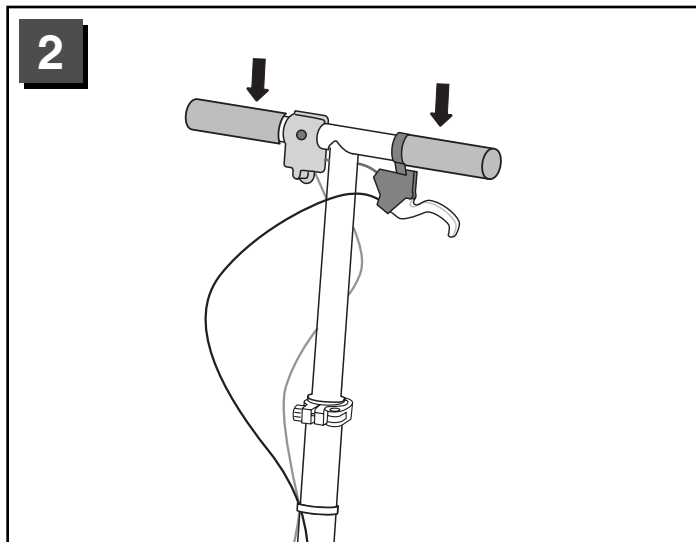

- Push down on the handlebar to be sure the handlebar is **locked** in place.

IMPORTANT! If the handlebar moves, please refer back to the top of this page to be sure you **lock** the handlebar in place.

Let's Go!

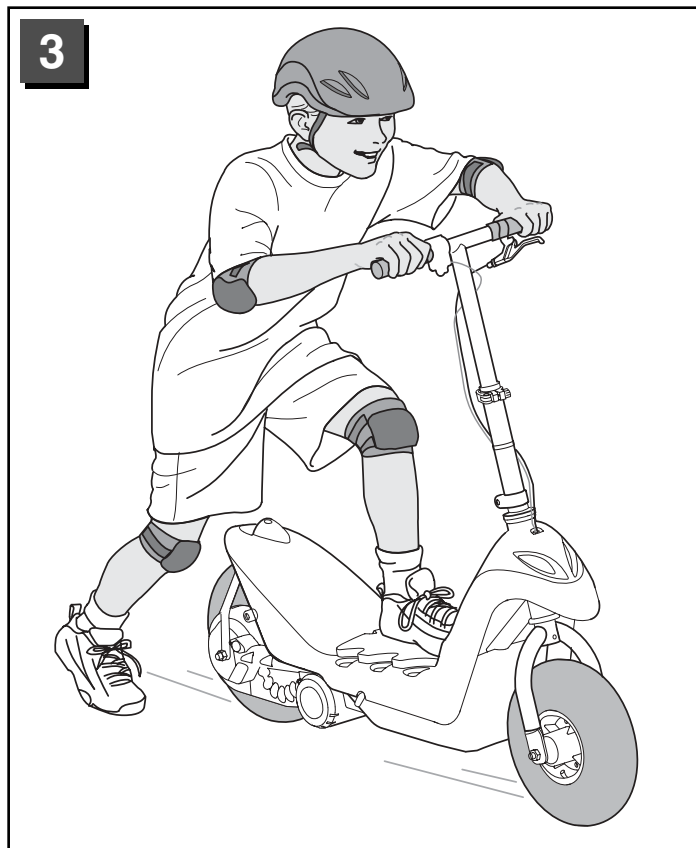

IMPORTANT! For a smooth start, place one foot on the footboard and push off a few steps with the other foot.

How to Operate Your Scooter

Let's Go!

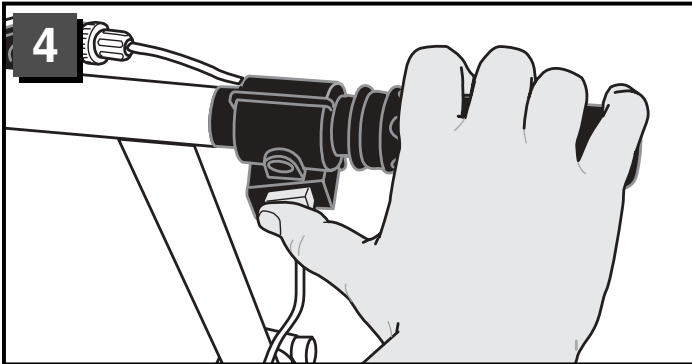

- Place your other foot on the back end of the scooter and press the throttle button. The scooter travels up to 7 mph (speed varies depending on rider weight and terrain).

Stop!

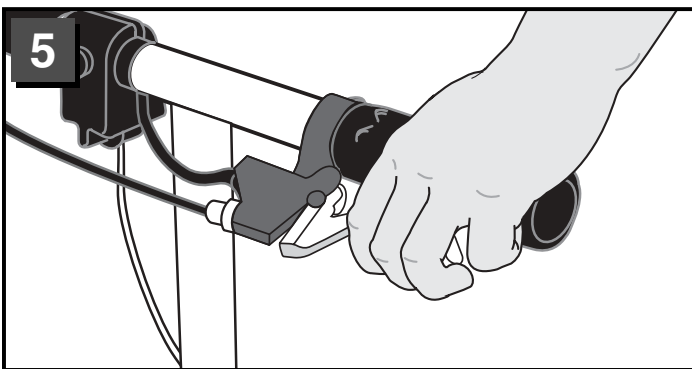

- To slow down or stop the scooter, release the throttle button and squeeze the brake handle, as shown.

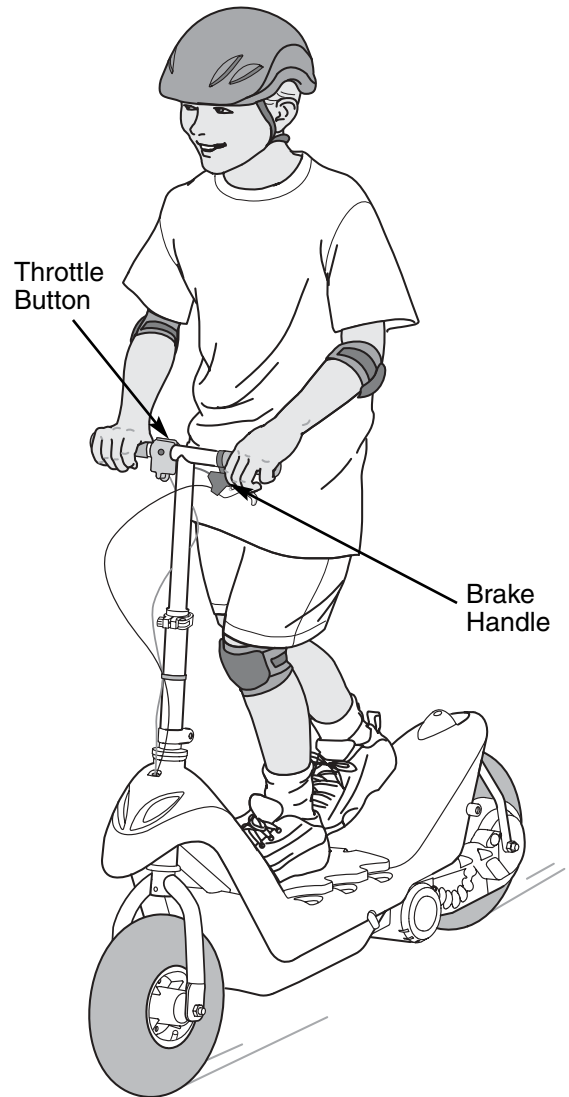

How to Operate Your Scooter

Kickstand

6

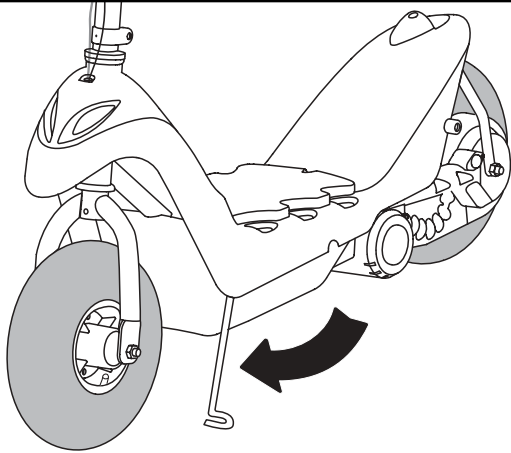

- To put the kickstand down, simply slide it toward the front end of the scooter.

7

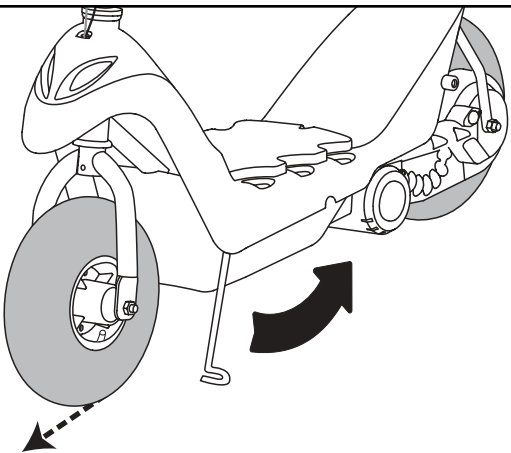

- To put the kickstand up, roll the scooter forward and then push the kickstand up.

L

Caring For Your Scooter

⚠ WARNING

To prevent tire explosion:

- Never inflate above 30 psi.
- Use only a hand pump to prevent over-inflation.

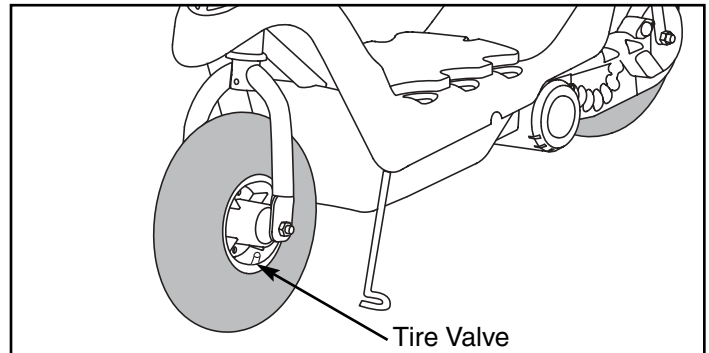

- When needed, inflate tires with a hand pump to **30 psi**.
- Check all screws, cap nuts and protective coverings regularly and tighten as required. Check plastic parts on a regular basis for cracks or broken pieces.
- During snowy or rainy weather, the scooter should be stored inside or under a protective cover. Remember to charge the battery at least once per month while your scooter is not in regular use.
- Avoid operating the scooter in wet or snowy conditions and do not spray the scooter with a hose. Do not wash the scooter with soap and water. Water or moisture in the motor or electrical switches can cause them to corrode and could cause switch or motor failure. Do not immerse the scooter.
- Avoid operating the scooter on sand, loose dirt or gravel. Sand, loose dirt or gravel in the motors or electrical switches can cause them to jam and could cause switch or motor failure.
- The scooter can be wiped down with a soft, dry cloth. For a shiny finish, you can wipe plastic parts with a non-wax furniture polish applied to a soft-cloth. Do not use automotive wax. Do not use soap and water or spray the scooter with a hose.
- To ensure that your scooter stays in good operating order, we recommend that you periodically have your scooter checked by a Power Wheels® authorized service center. For the location of the authorized service center nearest you, please visit us on-line at www.powerwheels.com or call 1-800-348-0751.
- **Tire repair must be done by a Power Wheels® authorized service center.** For the location of the authorized service center nearest you, please visit us on-line at www.powerwheels.com or call 1-800-348-0751.

IMPORTANT!

If the scooter does not run, please check the following:

- ✓ Battery is fully charged (18 hours for first-time charge; 14 hours after each use).
- ✓ Power button is in "ON" position. Please refer to page 16 in your Owner's Manual.
- ✓ Brake is properly adjusted. Please refer to pages 10-11 in your Owner's Manual.

If your scooter still does not run, you will need to reset the scooter's electronics. Please follow these instructions:

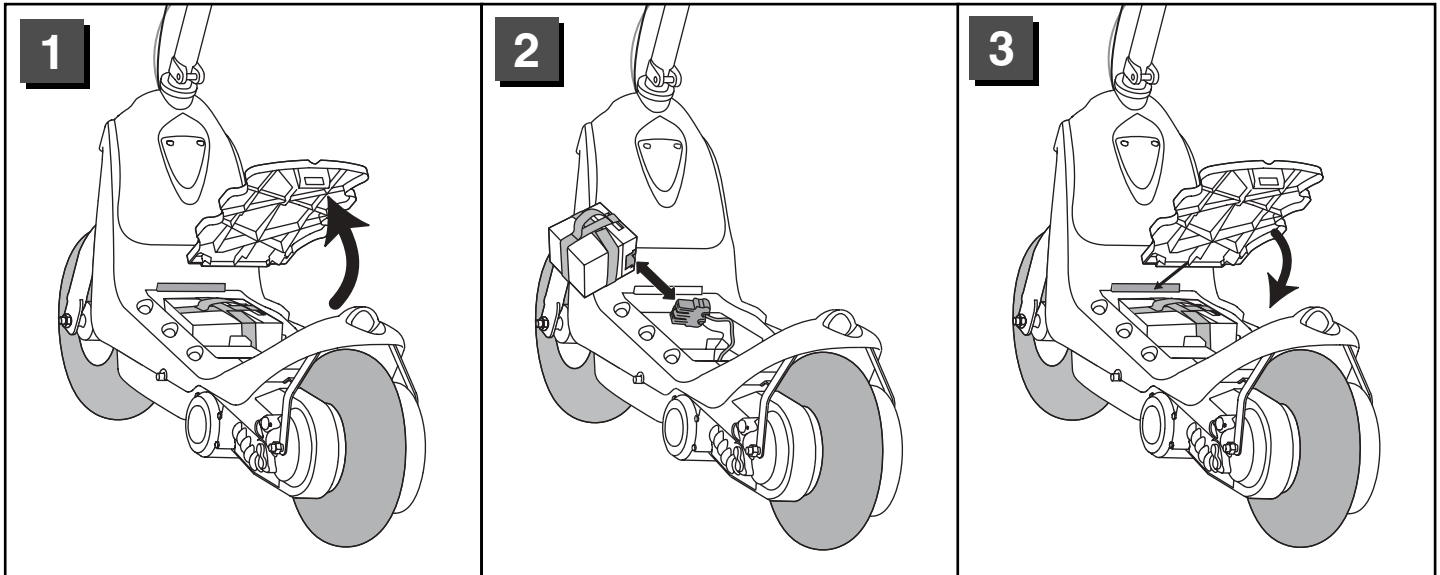

- While pressing the release button on the scooter floor, lift the footboard from the scooter (1).
- Remove the battery from the battery compartment (2).
- **Unplug** the motor harness connector from the battery socket (2).
- Now, **replace** the motor harness connector back into the battery socket. Push firmly to make sure the motor harness connector is completely inserted into the battery (2).
- Fit the battery back into the battery compartment, as shown. At an angle, insert the front tab on the footboard into the slot in the scooter floor. Push down on the footboard to "**snap**" it into place (3).
- Test to see if the scooter runs. While lifting the back wheel off the ground, press the button throttle. The back wheel should spin.
- If the back wheel does **not** spin, please contact a Power Wheels® Service Center. Please visit us on-line at www.powerwheels.com or call 1-800-348-0751 for the location of an authorized service center nearest you.

N

Problems and Solutions Guide

IMPORTANT! If you experience a problem with your scooter, first check the Problems and Solutions Guide below. If you still experience a problem, please contact Power Wheels® Consumer Relations, toll-free at **1-800-348-0751** between 8 AM and 6 PM (EST) Monday through Friday. Or, contact your local Power Wheels® authorized service center. For the location nearest you, please visit us on-line at www.powerwheels.com or call **1-800-348-0751**.

Problem	Possible Cause	Solution
Scooter does not run	Undercharged battery	Charge the battery. A new battery should have been charged for at least 18 hours before using the scooter for the first time. After first-time use, recharge the battery for at least 14 hours after each use. Never charge the battery longer than 30 hours.
		Check all connections. Make sure the charger connector is plugged into the battery, and that the charger is plugged into the wall.
		Make sure power flow to the wall outlet is "ON".
	Charger is not working	There is no sure way to tell if your charger is working unless you have a volt meter. If you suspect there is a problem with your charger, contact your local Power Wheels® authorized service center. They can test your charger for you.
	Tripped thermal fuse	Each Power Wheels® 12 volt battery has a built-in thermal fuse. A thermal fuse may "trip" and shut down operation of the scooter if the scooter is overloaded or the driving conditions too severe. The fuse will automatically reset itself after approximately 25 seconds, allowing the scooter to resume normal operation. To avoid repeated automatic shutdowns, do not overload the scooter by exceeding the 150 lb. maximum weight capacity or by towing anything behind the scooter. Do not drive up hills or run into fixed objects, which can cause the wheels to stop spinning while power is still being supplied to the motor. If a thermal fuse continually trips, contact your local Power Wheels® authorized service center.
	Loose wire or loose connectors	Check all wires and connectors. Make sure the motor harness connector is plugged into the battery, and that there are no loose wires around the motor.
	Dead battery	If your battery is old or if you have not followed Battery Care instructions, your battery may be dead. If you are unsure whether or not the battery is dead, you can have it tested at your local Power Wheels® authorized service center.
	Electrical switch damage	The electrical switches can become corroded due to exposure to water or moisture, or can jam due to loose dirt, sand or gravel. Contact your local Power Wheels® authorized service center for diagnosis and repair.
	Motor damage	Contact your local Power Wheels® authorized service center for diagnosis and repair.
Brake is not properly adjusted	If there is a gap between the brake handle and the brake base, the scooter will not run. You need to adjust the brake so that it is tight, and there is no gap. Please refer to section F, <i>Adjusting the Brakes</i> , page 10.	

Problems and Solutions Guide

Problem	Possible Cause	Solution
Scooter was running but suddenly stopped	Loose wire or loose connectors	Check all wires and connectors. Make sure the motor harness connector is plugged into the battery, and that there are no loose wires around the motor.
	Tripped thermal fuse	Each Power Wheels® 12 volt battery has a built-in thermal fuse. A thermal fuse may “trip” and shut down operation of the scooter if the scooter is overloaded or the driving conditions too severe. The fuse will automatically reset itself after approximately 25 seconds, allowing the scooter to resume normal operation. To avoid repeated automatic shutdowns, do not overload the scooter by exceeding the 150 lb. maximum weight capacity or by towing anything behind the scooter. Do not drive up hills or run into fixed objects, which can cause the wheels to stop spinning while power is still being supplied to the motor. If a thermal fuse continually trips, contact your local Power Wheels® authorized service center.
	Brake is not properly adjusted	If there is a gap between the brake handle and the brake base, the scooter will not run. You need to adjust the brake so that it is tight, and there is no gap. Please refer to section F, <i>Adjusting the Brakes</i> , page 10.
Short run time (less than 1 - 3 hours per charge)	Undercharged battery	Charge the battery. A new battery should have been charged for at least 18 hours before using the scooter for the first time. After first-time use, recharge the battery for at least 14 hours after each use. Never charge the battery longer than 30 hours.
		Check all wires and connections. Make sure the charger connector is plugged into the battery, and that the charger is plugged into the wall.
		Make sure power flow to the wall outlet is “ON”.
	Overcharged battery	Do not charge the battery longer than 30 hours. If you suspect that your battery is damaged as a result of overcharging, contact your local Power Wheels® authorized service center. They can test your battery for you.
	Battery is old and will not accept full charge	Even with proper care, a rechargeable battery does not last forever. Average battery life is 1 to 3 years depending on scooter use and use conditions. Replace the battery with a new Power Wheels® 12 volt rechargeable battery. Do not substitute parts.
	Tripped thermal fuse	Each Power Wheels® 12 volt battery has a built-in thermal fuse. A thermal fuse may “trip” and shut down operation of the scooter if the vehicle is overloaded or the driving conditions too severe. The fuse will automatically reset itself after approximately 25 seconds, allowing the scooter to resume normal operation. To avoid repeated automatic shutdowns, do not overload the scooter by exceeding the 150 lb. maximum weight capacity or by towing anything behind the scooter. Do not drive up hills or run into fixed objects, which can cause the wheels to stop spinning while power is still being supplied to the motor. If a thermal fuse continually trips, contact your local Power Wheels® authorized service center.

Problems and Solutions Guide

Problem	Possible Cause	Solution
Scooter runs sluggishly	Undercharged battery	Charge the battery. A new battery should have been charged for at least 18 hours before using the scooter for the first time. After first-time use, recharge the battery for at least 14 hours after each use. Never charge the battery longer than 30 hours.
		Check all connections. Make sure the charger connector is plugged into the battery, and that the charger is plugged into the wall.
		Make sure power flow to the wall outlet is "ON".
	Battery needs charging	Be sure to charge the battery after each use.
	Battery is old and will not accept full charge	Even with proper care, a rechargeable battery does not last forever. Average battery life is 1 to 3 years depending on the scooter use and use conditions. Replace the battery with a new Power Wheels® 12 volt rechargeable battery. Do not substitute parts.
	Scooter is overloaded	Make sure you do not overload the scooter by allowing more than 1 rider at one time, by exceeding the 150 lb. maximum weight capacity, or by towing objects behind the scooter.
	Driving conditions are too stressful	Use only on generally level ground.
Sometimes the scooter doesn't run, but other times it does	Loose wire or connector	Check all wires around the motors and all connectors to make sure they are tight.
	Motor or electrical switch damage	Contact your local Power Wheels® authorized service center for diagnosis and repair.
	Brake is not properly adjusted	If there is a gap between the brake handle and the brake base, the scooter will not run. You need to adjust the brake so that it is tight, and there is no gap. Please refer to section F, <i>Adjusting the Brakes</i> , page 10.
When the throttle button is pressed, the scooter won't run without a push	Loose wire or connector	Check all wires around the motor and all connectors to make sure they are tight.
	"Dead Spot" on motor	Contact your local Power Wheels® authorized service center for diagnosis and repair.
Charger gets warm during use	It is normal for some chargers to get warm during use and is not reason for concern.	No action required.
		If your charger does not get warm during use, it does not mean that it is not working properly.
Battery makes a sizzling or gurgling noise when charging	It is normal for some batteries to make noise and swell slightly while charging and is not reason for concern.	No action required.
		If your battery does not make noise or swell slightly during charging, it does not mean that it is not accepting the charge.

If, after reviewing the Problems and Solutions Guide, the scooter still fails to operate, please contact your nearest authorized service center or contact Power Wheels® Consumer Relations toll-free at **1-800-348-0751**.

Hint: For faster service when calling Consumer Relations, completely charge the battery before calling and have the following available by the phone:

- scooter,
- scooter model number (see label in battery compartment),
- scooter production run number (see label in battery compartment).

O

Limited Warranty

***One year limited warranty from the date of purchase on the Power Wheels® vehicle.
Six month limited warranty on the 12 volt battery.**

For the original purchaser, this one year limited warranty covers the Power Wheels® ride-on vehicle (purchased from Power Wheels®) against defects in materials and workmanship. The six month limited warranty applies only to the 12 volt battery included by Power Wheels® with the original purchase of the vehicle.

This warranty covers normal use and does not cover the Power Wheels® vehicle or battery if damaged by unreasonable use, neglect, accident, abuse, misuse, improper service or other causes not arising out of defects in materials or workmanship. Evidence of any attempt at consumer repair will void this warranty. **THIS WARRANTY DOES NOT COVER, AND IS INTENDED TO EXCLUDE, ANY LIABILITY ON THE PART OF POWER WHEELS®, WHETHER UNDER THIS WARRANTY OR IMPLIED BY LAW OR ANY INDIRECT OR CONSEQUENTIAL DAMAGES FOR BREACH OF WARRANTY. SOME STATES DO NOT ALLOW THE EXCLUSION OR LIMITATION SO THIS LIMITATION MAY NOT APPLY TO YOU.**

Should you need service or assistance with your vehicle during the warranty period, **do not return the vehicle to the store.** Power Wheels® has provided a nationwide network of authorized service centers. For a list of authorized service centers, please visit us on-line at www.powerwheels.com. Power Wheels® is continually expanding our Authorized Service Center Network. If there is not an authorized service center in your area, please call Consumer Relations for information, **1-800-348-0751**.

This warranty gives you specific legal rights, and you may also have other rights which may vary from state to state. **Please save your original sales receipt.**

P

FCC Statement (United States Only)

This equipment has been tested and found to comply with the limits for a Class B digital device, pursuant to part 15 of the FCC rules. These limits are designed to provide reasonable protection against harmful interference in a residential installation. This equipment generates, uses and can radiate radio frequency energy and, if not installed and used in accordance with the instructions, may cause harmful interference to radio communications. However, there is no guarantee that interference will not occur in a particular installation. If this equipment does cause harmful interference to radio or television reception, which can be determined by turning the equipment off and on, the user is encouraged to try to correct the interference by one or more of the following measures:

Reorient or relocate the receiving antenna.

Increase the separation between the equipment and receiver.

Connect the equipment into an outlet on a circuit different from that to which the receiver is connected.

Consult the dealer or an experienced radio/TV technician for help.

NOTE: Changes or modifications not expressly approved by the manufacturer responsible for compliance could void the user's authority to operate the equipment.

IMPORTANT!

DO NOT use this scooter for the first time until you have charged the battery for 18 hours.

Remember to...

- ✓ Charge the battery immediately after each use.
- ✓ Charge the battery once a month during storage, even if the scooter has not been used.

Failure to follow these instructions will permanently damage your battery and void your warranty. Please refer to the Battery Care Section in this manual for more information.

DO NOT Return your Scooter to the Store!



If you are missing parts or need assistance, please call us toll-free:

Power Wheels® Consumer Relations

1-800-348-0751

8 AM - 6 PM EST, Monday through Friday.

Or contact your local, independently owned and operated Power Wheels® Authorized Service Center.

For the location nearest you, visit us on-line at www.powerwheels.com.

