

# THOMAS & FRIENDS™

## TALKING THOMAS & PERCY TRAIN SET



### INSTRUCTIONS

Keep these instructions for future reference as they contain important information.



**UNITED STATES**  
Fisher-Price, Inc., 636 Girard Avenue, East Aurora, NY 14052.  
Consumer Services: 1-800-432-5437.

**CANADA**  
Mattel Canada Inc., 6155 Freemont Blvd., Mississauga, Ontario L5R 3W2. Consumer Services/Service à la clientèle : 1-800-432-5437.  
www.service.mattel.com.

**GREAT BRITAIN**  
Mattel U.K. Limited, The Porter Building, 1 Brunel Way, Slough SL1 1FQ, UK. www.service.mattel.com/uk.

**NETHERLAND**  
Mattel Europa B.V., Gondel 1, 1186 MJ Amstelveen, Nederland.

**AUSTRALIA**  
Mattel Australia Pty. Ltd., 658 Church Street, Locked Bag #870, Richmond, Victoria 3121 Australia. Consumer Advisory Service 1300 135 312.

**NEW ZEALAND**  
16-18 William Pickering Drive, Albany 1331, Auckland.

**SOUTH AFRICA**  
Mattel South Africa (PTY) LTD, Office 102 I3, 30 Melrose Boulevard, Johannesburg 2196.

Thomas the Tank Engine & Friends™  
CREATED BY BRITAIN ALLCROFT

Based on the Railway Series by The Reverend W Awdry.  
©2020 Gullane (Thomas) Limited. Thomas the Tank Engine & Friends and Thomas & Friends are trademarks of Gullane (Thomas) Limited.  
©2020 HIT Entertainment Limited. HIT and the HIT logo are trademarks of HIT Entertainment Limited.

©2020 Mattel. ® and ™ designate U.S. trademarks of Mattel, except as noted. **PRINTED IN CHINA.**  
Mattel East Asia Ltd., Room 503-09, North Tower, World Finance Centre, Harbour City, Tsimshatsui, HK, China. Tel.: (852) 3185-6500.

GLK80



GLK80-0970G2-1102448520-DOM

## What's Included

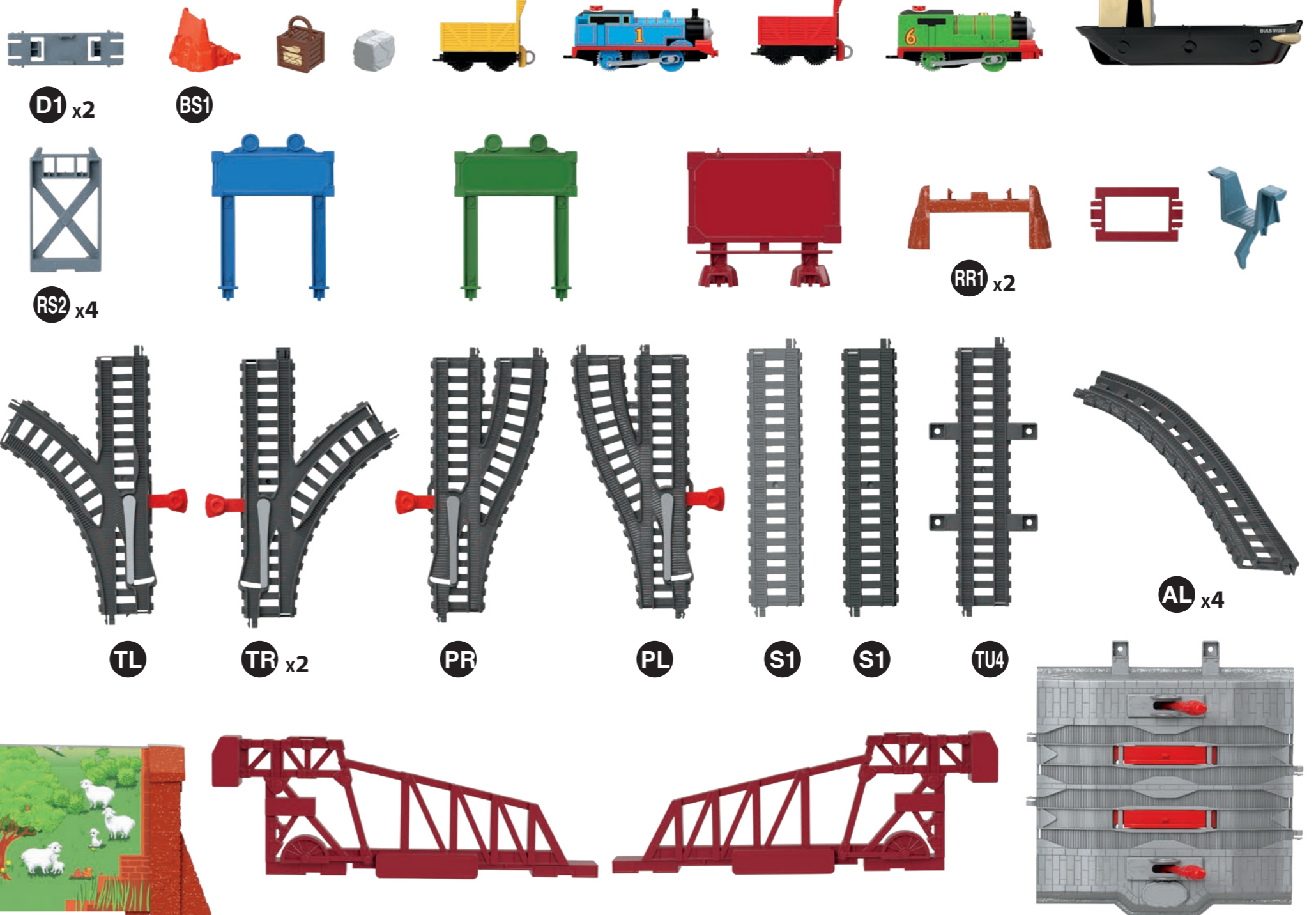

## Battery Information

- REQUIRES:**
- Phillips screwdriver (not included) for battery installation.
  - Four AAA (LR03) **alkaline** batteries (included).

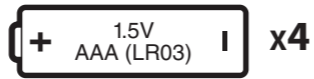

### BATTERY INSTALLATION

Access the battery compartment by loosening the screw in the bottom of each engine and separating the top halves of the engine from the bottom halves of the engine. Remove the worn batteries and properly dispose. Insert new batteries as indicated inside each battery compartment. Re-assemble the halves of each engine and tighten each screw. If an engine begins to malfunction, first check battery installation. You may need to reset the electronics by removing the batteries and reinstalling them. If an engine continues to malfunction or no longer operates, it's time to replace the batteries with fresh batteries. For longer life, use **alkaline** batteries.

### BATTERY SAFETY INFORMATION

In exceptional circumstances batteries may leak fluids that can cause a chemical burn injury or ruin your product. To avoid battery leakage:

- Non-rechargeable batteries are not to be recharged.
- Rechargeable batteries are to be removed from the product before being charged.
- Rechargeable batteries are only to be charged under adult supervision.
- Do not mix alkaline, standard (carbon-zinc), or rechargeable batteries.
- Do not mix old and new batteries.
- Only batteries of the same or equivalent type as recommended are to be used.
- Batteries are to be inserted with the correct polarity (+ and -).
- Exhausted batteries are to be removed from the product.
- The supply terminals are not to be short-circuited.
- Dispose of batteries safely.
- Do not dispose of this product in a fire. The batteries inside may explode or leak.



Protect the environment by not disposing of this product or any batteries with household waste. This symbol indicates that this product shall not be treated as household waste. Check your local authority for recycling advice and facilities.

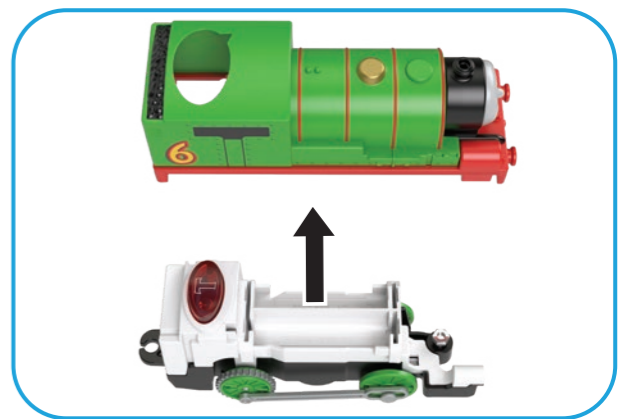
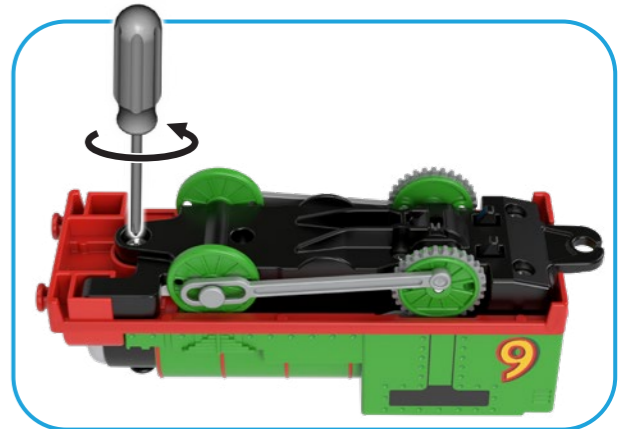
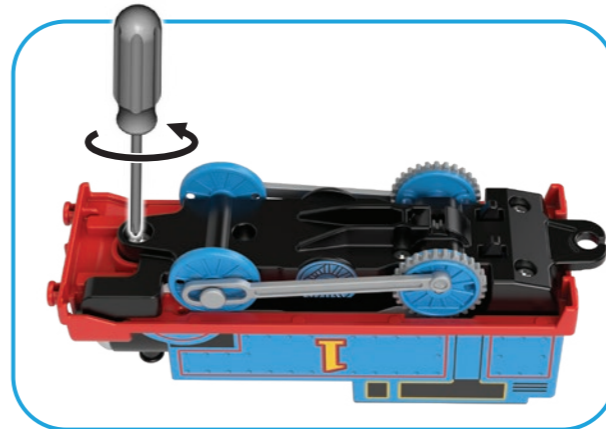

### FCC STATEMENT (UNITED STATES ONLY)

This equipment has been tested and found to comply with the limits for a Class B digital device, pursuant to Part 15 of the FCC rules. These limits are designed to provide reasonable protection against harmful interference in a residential installation. This equipment generates uses and can radiate radio frequency energy and, if not installed and used in accordance with the instructions, may cause harmful interference to radio communications. However, there is no guarantee that interference will not occur in a particular installation. If this equipment does cause harmful interference to radio or television reception, which can be determined by turning the equipment off and on, the user is encouraged to try to correct the interference by one or more of the following measures:

- Reorient or relocate the receiving antenna.
- Increase the separation between the equipment and receiver.
- Consult the dealer or an experienced radio/TV technician for help.

NOTE: Changes or modifications not expressly approved by the manufacturer responsible for compliance could void the user's authority to operate the equipment. This device complies with Part 15 of the FCC Rules. Operation is subject to the following two conditions: (1) This device may not cause harmful interference, and (2) this device must accept any interference received, including interference that may cause undesired operation.

### CAN ICES-3 (B)/NMB-3 (B)

Operation is subject to the following two conditions: (1) this device may not cause interference, and (2) this device must accept any interference, including interference that may cause undesired operation of the device. L'utilisation de ce dispositif est autorisée seulement aux conditions suivantes : (1) il ne doit pas produire de brouillage et (2) il doit pouvoir tolérer tout brouillage radioélectrique reçu, même si ce brouillage est susceptible de compromettre son fonctionnement.



# Assembly

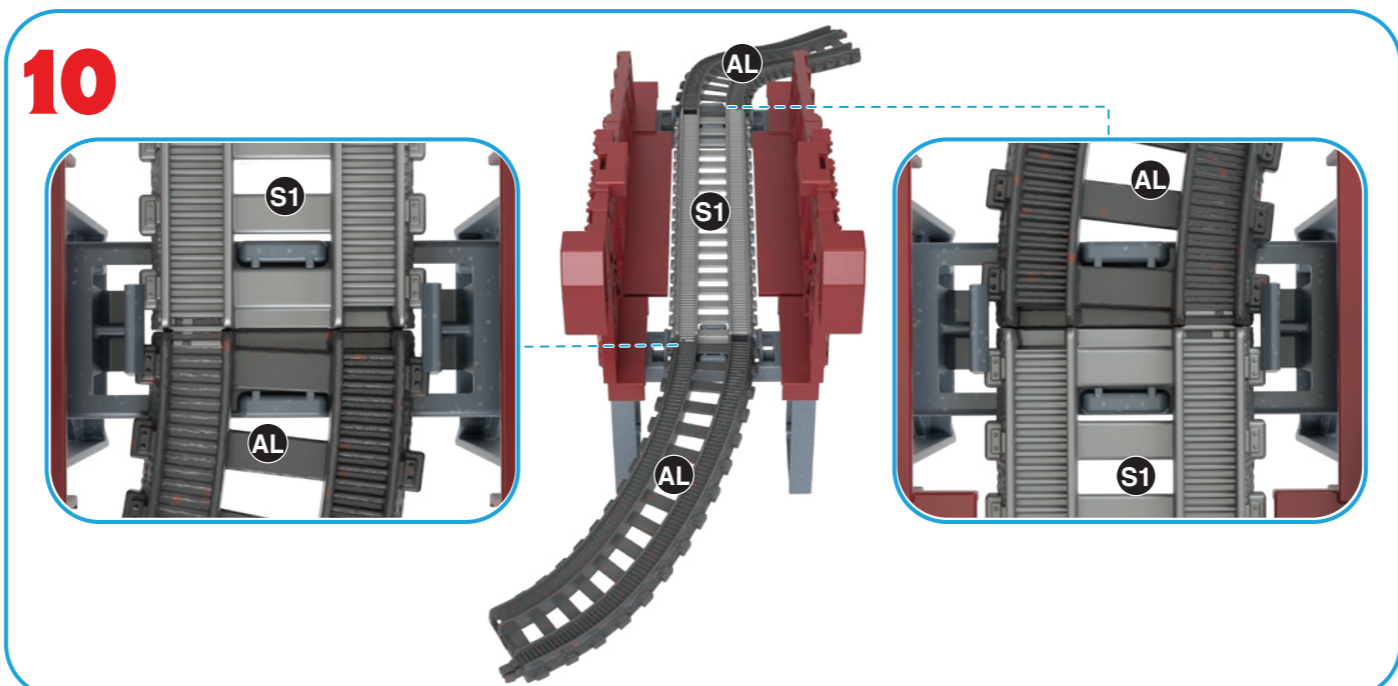
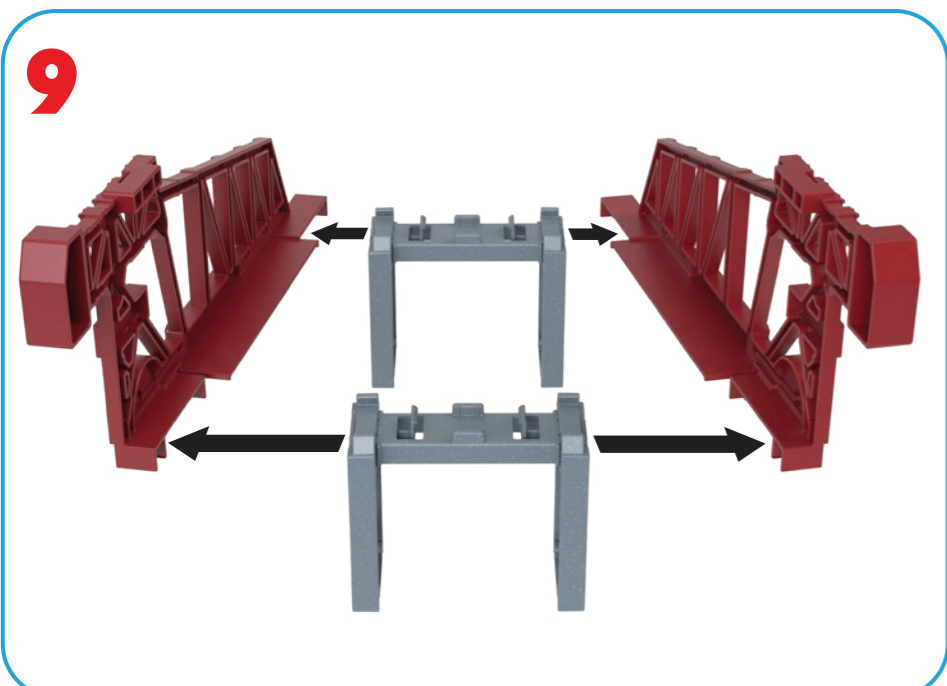
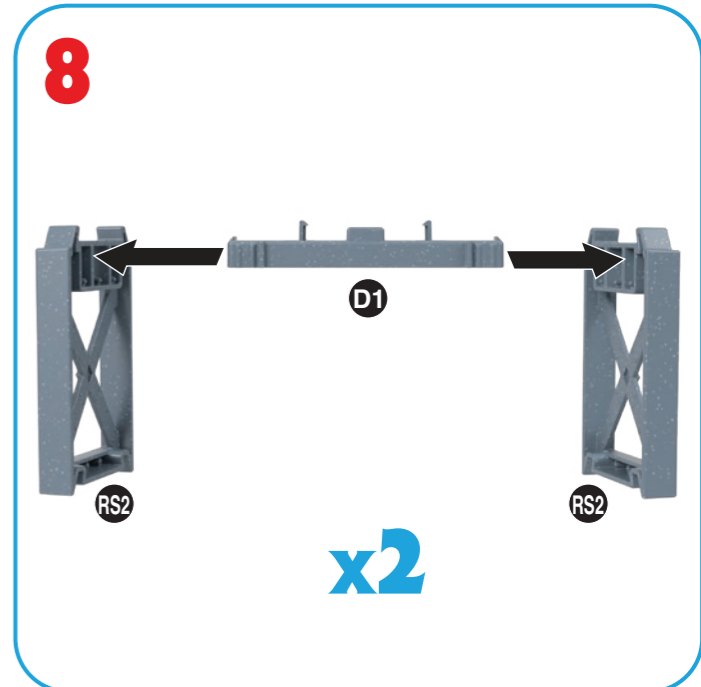
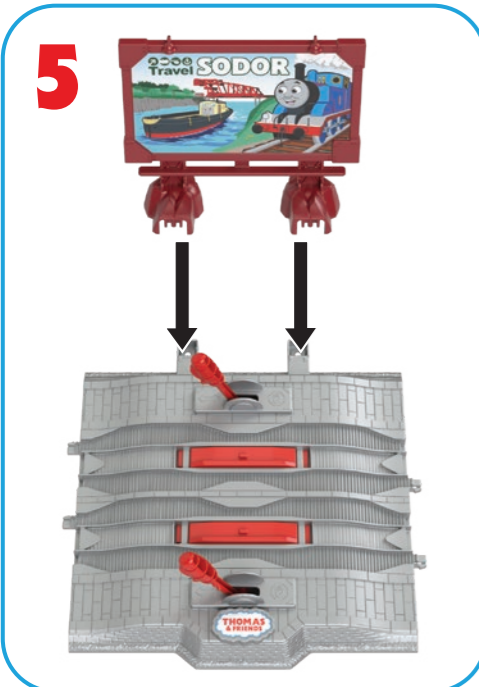
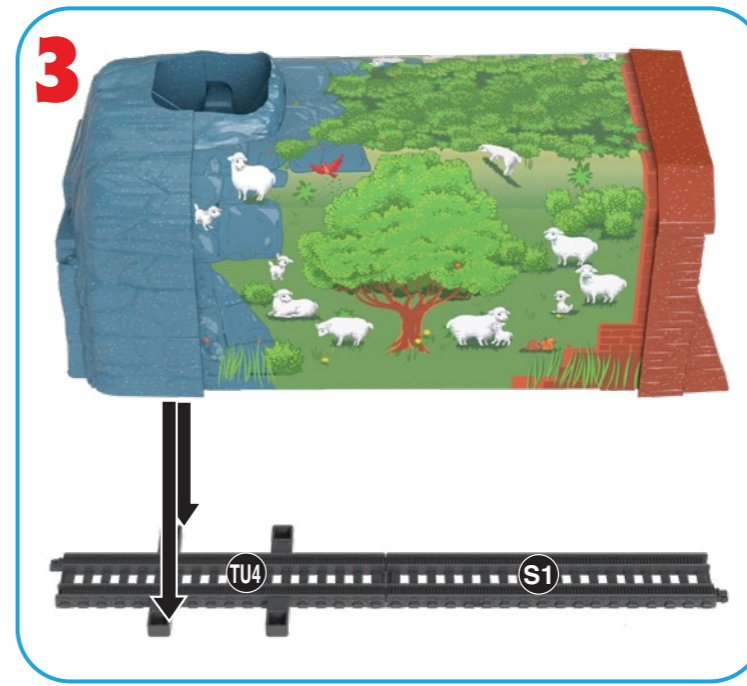
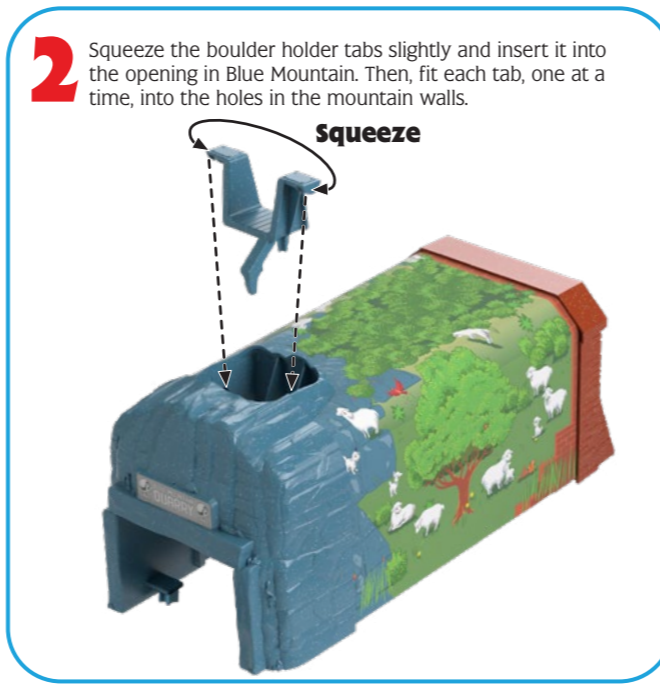

# Track Layout

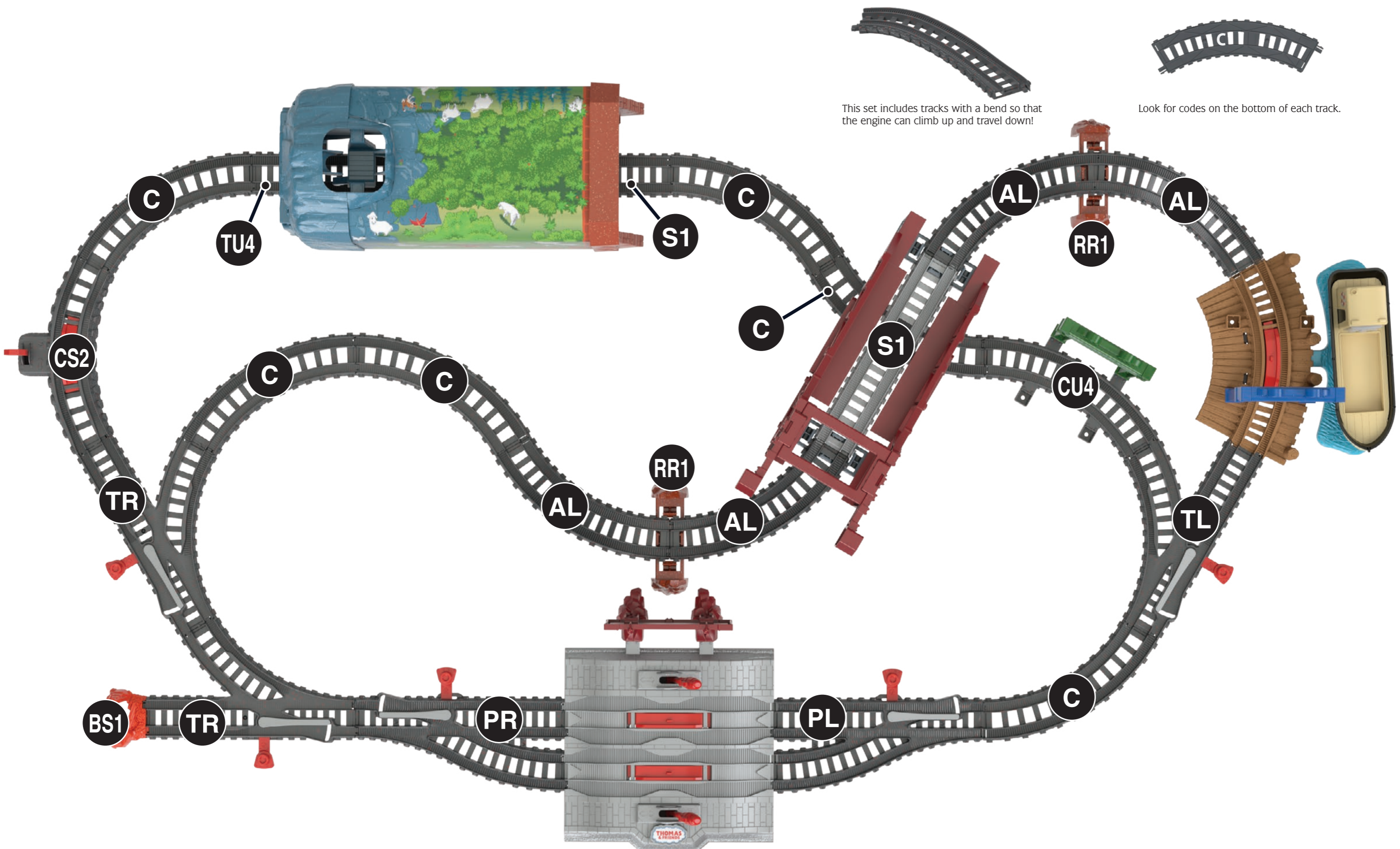



# Let's Play!

**1** Set the stop track and the loading station to "Stop". Dock Bulstrode at Brendam Docks.

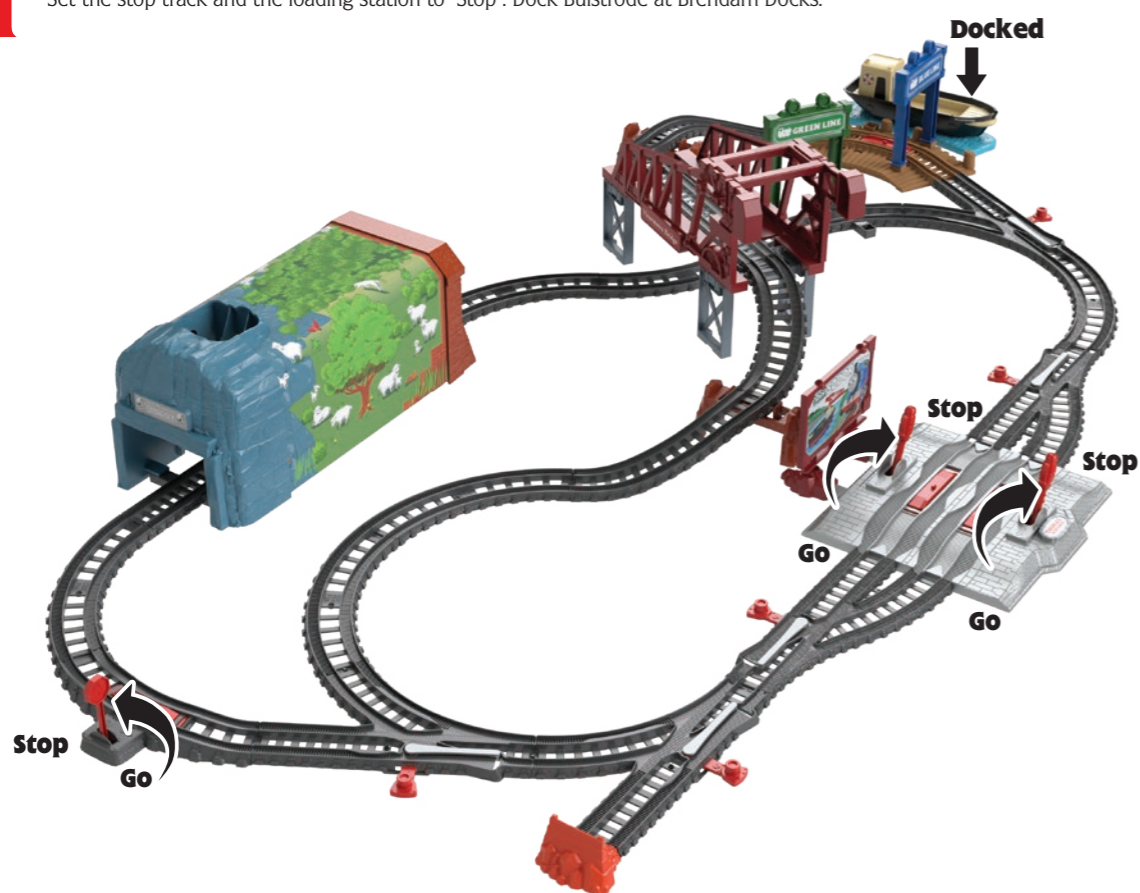

**2** Load the boulder into Blue Mountain.



**3** Load a crate into Bulstrode.



**4** Place the engines with the cargo cars on the loading station track. The loading station track includes guides to position the engines just right! Press the engine buttons to turn power ON. Flip the levers and watch the engines GO! Push the levers back into the stop position for the next time the engines come around the track. Press the buttons again to pause engine movement and listen to them talk to each other. Press and hold the buttons for about three seconds to turn each engine OFF completely. Want to make an engine go again? Press the button!

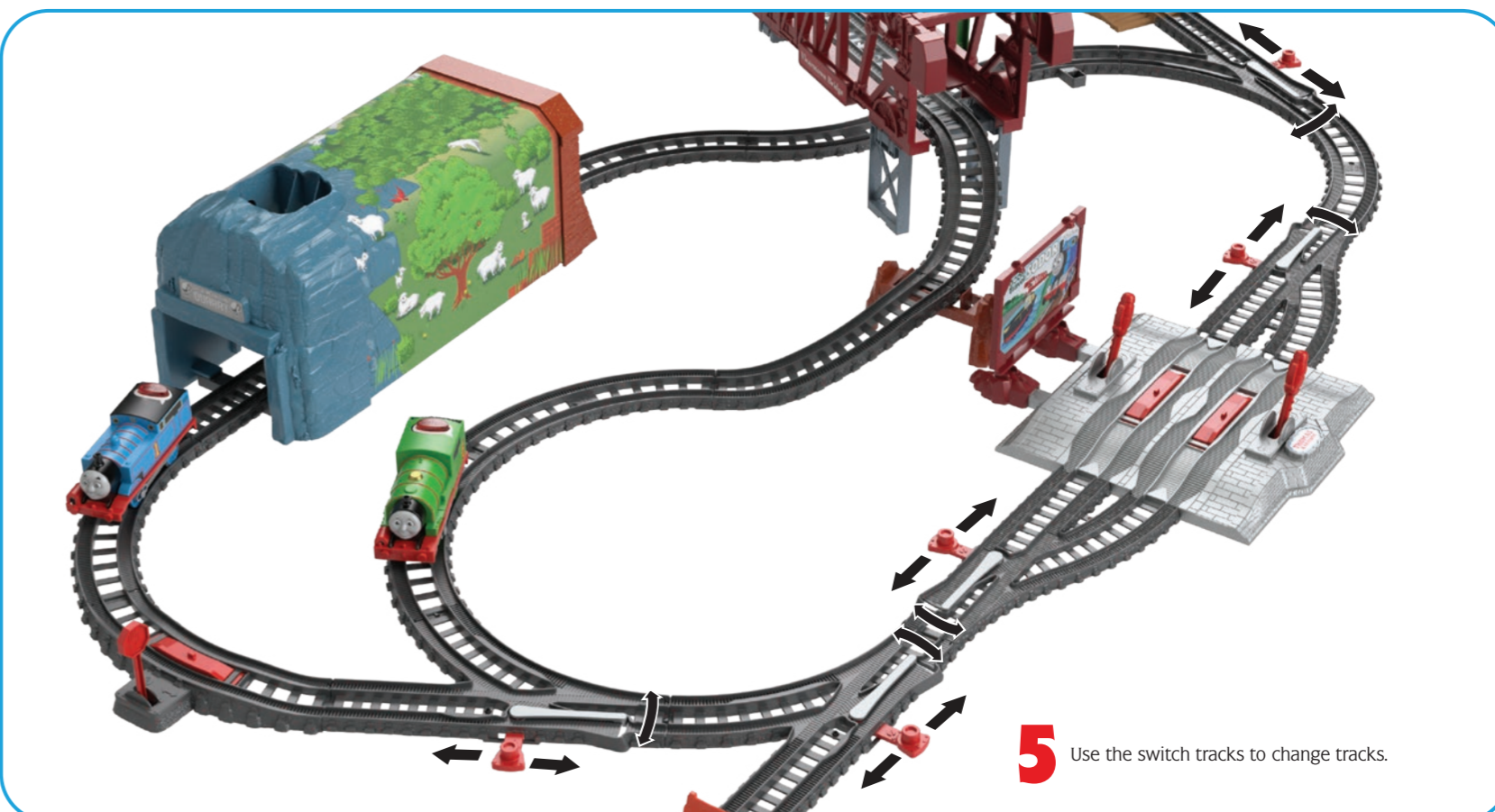

**5** Use the switch tracks to change tracks.



**6** When the engines arrive at the loading station, they'll recognize each other! Then flip the levers back to release the engines.



**7** With Bulstrode docked, engines must stop at Brendam Docks. Listen to the engines chat while waiting for Bulstrode to leave.

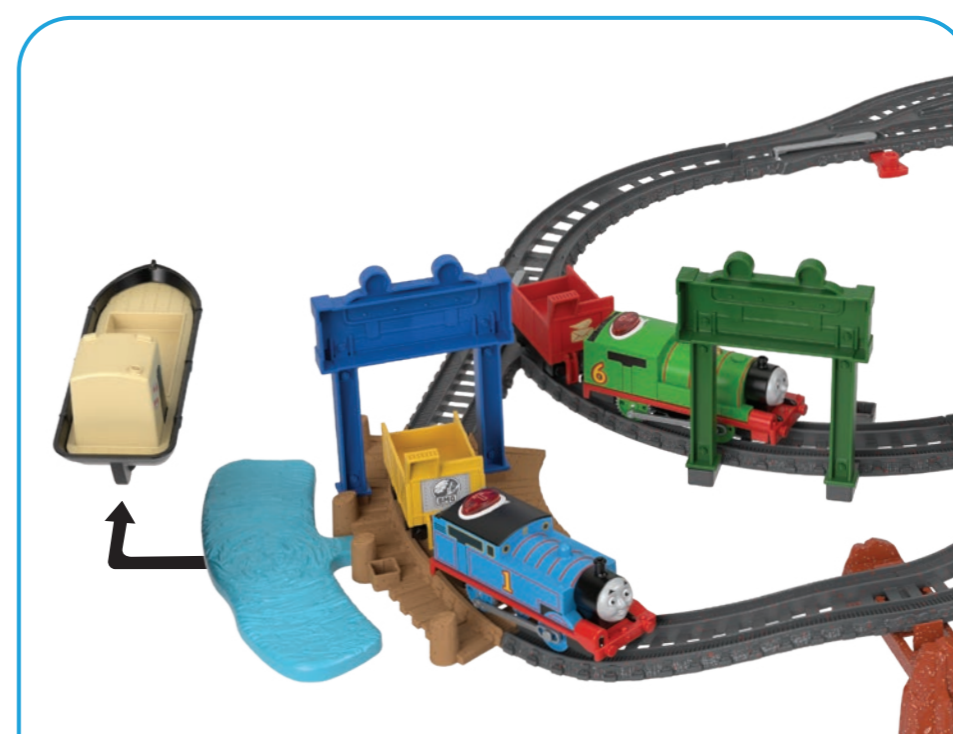

**8** Launch Bulstrode to release the engine.

**9** When an engine passes through Henry's Tunnel and Blue Mountain, the boulder falls into the cargo car!



**10** Another stop track means it's time to stop again!



**11** Push the lever forward to release the engine.



## Try these track layouts!

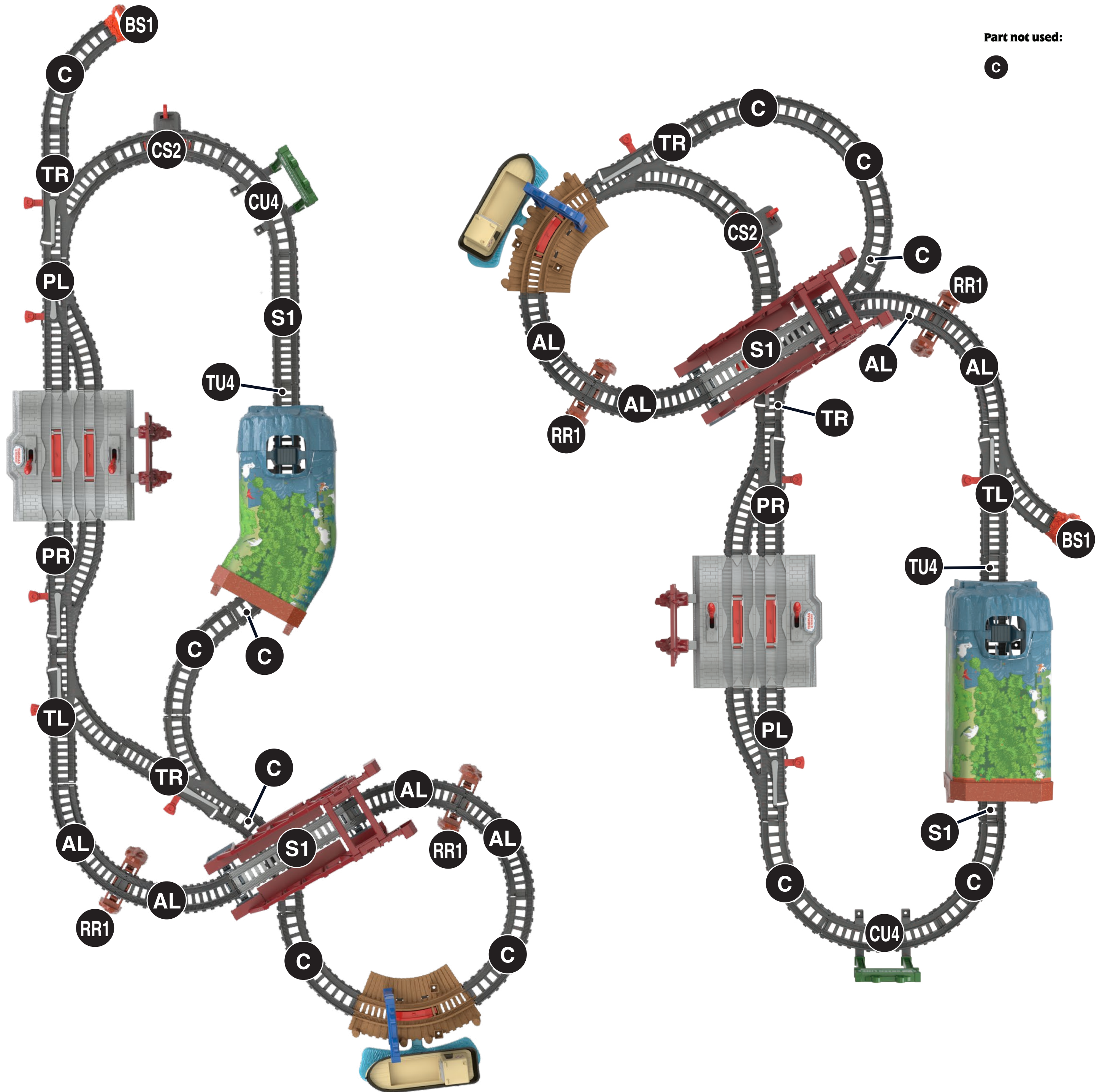

## Troubleshooting

### PROBLEM

### SOLUTION

An engine does not move but still talks and its front light blinks three times

When battery power is low, the engine front light blinks three times. Be sure to replace batteries with two, new AAA (LR03) **alkaline** batteries.

When an engine stops, the other engine stops and talks

If the button on an engine is pressed to pause movement or it is stopped on a stop track, the loading station or Brendan Dock, the other engine stops to chat and then starts moving again.

An engine doesn't move or talk

The engine is in sleep mode (after about five minutes of inactivity) or is paused. Press the button on the engine to wake it up. Batteries are dead. Replace the batteries with two, new AAA (LR03) **alkaline** batteries

The engines do not react to each other

Battery power may be low in either or both engines. Replace batteries with two, new AAA (LR03) **alkaline** batteries.  
The distance between the engines is too great. Make sure the engines are no further apart than six feet (1,8 meters).  
The light in the room may be too bright. Try dimming light by closing curtains or turning a light off.  
The engines enter sleep mode after about five minutes of inactivity. Press the button on each engine to wake them up.

The engines do not seem to totally turn off

Press and hold each engine button for about three seconds to completely turn off power.

An engine from another set does not work on track in this set.

Some engines from other sets will not fit on this track set.  
Only talking engines will interact with engines included with this set.