



H7461, J1718



Product features may vary from the picture above.

**For use with a Power Wheels®
12-volt lead acid battery only.**

**This product is not intended for children; it is for adult use only.
This charger is not a toy.**

**Please read this booklet before first-time use.
Keep these instructions for future reference,
as they contain important information.**

12 Volt Quick Charger

IMPORTANT INFORMATION

DANGER

To prevent electric shock, do not immerse in water; wipe clean with a damp cloth.

WARNING

Use of the wrong type battery or charger could cause a fire/explosion resulting in serious injury.

CAUTION

Use the charger in dry locations only.

IMPORTANT INFORMATION

- **IMPORTANT!** A battery can be severely damaged if it is not charged after each use. **For maximum battery life, charge batteries 100% (solid green) every other charge.**
- If your battery is new, charge the battery 100% (solid green).
- Do not charge the battery longer than 30 hours.
- **Adults Note:** Regularly examine the charger for damage to the cord, plug, housing or other parts that may result in the risk of fire, electric shock or injury. In the event of any damage, do not use the charger until the damage has been properly repaired. Please call **1-800-348-0751**.
- Before charging the battery, examine the battery case for cracks and other damage which may cause sulfuric acid (electrolyte) to leak during the charging process. If damage is detected, do not charge the battery or use it in your vehicle. Battery acid is very corrosive and can cause severe damage to the surfaces it contacts.
- Do not charge the battery on a surface (such as a kitchen counter top) which could be damaged by the acid contained inside the battery. Take precautions to protect the surface on which you charge the battery.
- Do not short circuit the battery.
- The battery must be upright while charging.
- Disconnect the charger before cleaning.
- Charger specifications are as follows:
 - Input** 100-240 V AC 50/60Hz 50W
 - Output** 12V DC 2.5A

WARNING

• **PREVENT FIRE**

- Use of the wrong type battery or charger could cause a fire or explosion resulting in serious injury.
- Use of Power Wheels® components in products other than Power Wheels® vehicles could cause overheating, fire or explosion.
- The battery must be handled by adults only. The battery is heavy and contains sulfuric acid (electrolyte). Dropping the battery could result in serious injury.
- Never allow children to charge the battery. Battery charging must be done by adults only. A child could be injured by the electricity involved in charging the battery.
- Read the safety instructions on the battery.
- Examine the battery, charger and their connectors for excessive wear or damage each time you charge the battery. If damage or excessive wear is detected, do not use the charger or the battery until you have replaced the worn or damaged part.

CHARGING INSTRUCTIONS



Status	Charge	Approximate Time
Solid Red	Charging	--
Flashing Green	Ready for Use	2 hours
Solid Green	100% (Full)*	6-8 hours
Flashing Red	No Charge**	--

* For maximum battery life, charge battery 100% (solid green) every other charge.

** Error - wrong or dead battery.

CHARGING INSTRUCTIONS

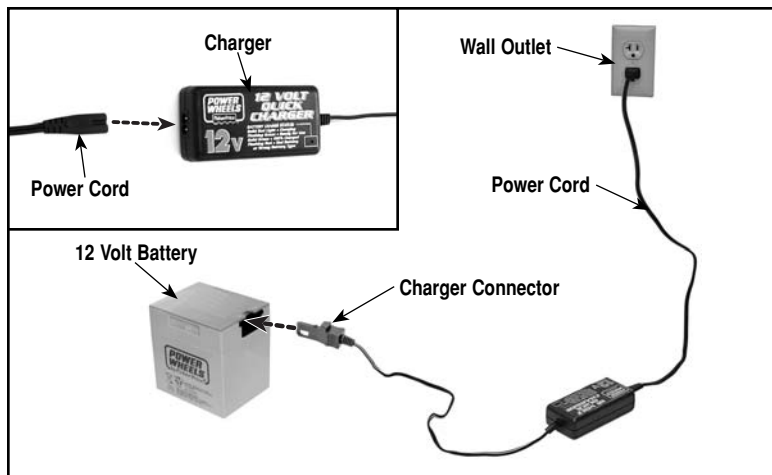

- Plug the power cord into the charger.
- Plug the charger connector into the 12-volt battery.
- Plug the power cord into a standard 120 volt wall outlet.

Note: The charger may be hot to the touch while charging. New batteries may make a “sizzling” or “bubbling” noise and swell slightly. These are normal conditions and do not indicate a problem.

- Charge the battery 100% (solid green) or Ready for Use (flashing green). For maximum battery life, charge battery 100% (solid green) every other charge.
- Unplug the charger from the wall outlet when not in use.

PROBLEMS AND SOLUTIONS

Problem	Possible Cause	Solution
No status light	No power to charger	Make sure power flow to the wall outlet is "ON".
	Loose connections	Check connections of all plugs. Make sure the charger connector is tightly plugged into the battery and the power cord connector is tightly plugged into both the charger and the wall outlet.
	Bad charger	There is no sure way to tell if your charger is working unless you have a volt meter. If you suspect there is a problem with your charger, contact Power Wheels® Consumer Relations.
	Wrong battery	This charger is intended for use only with a Power Wheels® 12-volt lead acid battery.
Flashing red status light	Loose connections	Check connection of all plugs. Make sure the charger connector is tightly plugged into the battery and the power cord connector is tightly plugged into both the charger and the wall outlet.
	Undercharged battery	Battery needs a 100% (solid green) charge every other use.
	Battery dead	Replace battery with a new, Power Wheels® 12-volt lead acid battery.
Solid red status light	Undercharged battery	Charge battery 100% (solid green) or Ready for Use (flashing green).

PROBLEMS AND SOLUTIONS

Problem	Possible Cause	Solution
Battery is warm while charging	Normal while quick charging	No action required.
Charger is hot while charging	Normal while quick charging	No action required.
Short vehicle run time or vehicle runs sluggishly	Undercharged battery	Charge battery 100% (solid green) or Ready for Use (flashing green).
Flashing green status light - but vehicle does not run	Battery dead	In rare situations, a severely depleted (dead) battery will give a false, Ready for Use (flashing green) status. Try charging the battery again for 6-8 hours. If your vehicle still won't run, you will need to replace your battery with a new, Power Wheels® 12-volt lead acid battery.
Solid green status light - but vehicle does not run	Battery dead	In rare situations, a severely depleted (dead) battery will give a false, 100% (solid green) status. Try charging the battery again for 6-8 hours. If your vehicle still won't run, you will need to replace your battery with a new, Power Wheels® 12-volt lead acid battery.
Flashing green status light does not progress to a solid green status light after 6-8 hours of charging and vehicle does not run	Battery may be dead	Unplug the charger from the battery and wall outlet for at least 12 hours. Now, charge the battery again for 6-8 hours. If the status light flashes red, or you get the same results, replace the battery with a new, 12-volt lead acid battery.

FCC STATEMENT

(United States Only)

This equipment has been tested and found to comply with the limits for a Class B digital device, pursuant to part 15 of the FCC rules. These limits are designed to provide reasonable protection against harmful interference in a residential installation. This equipment generates, uses and can radiate radio frequency energy and, if not installed and used in accordance with the instructions, may cause harmful interference to radio communications. However, there is no guarantee that interference will not occur in a particular installation. If this equipment does cause harmful interference to radio or television reception, which can be determined by turning the equipment off and on, the user is encouraged to try to correct the interference by one or more of the following measures:

Reorient or relocate the receiving antenna.

Increase the separation between the equipment and receiver.

Connect the equipment into an outlet on a circuit different from that to which the receiver is connected.

Consult the dealer or an experienced radio/TV technician for help.

Note: Changes or modifications not expressly approved by the manufacturer responsible for compliance could void the user's authority to operate the equipment.

CUSTOMER SERVICE

If you have any questions about this product, please call our toll-free service lines at **1-800-348-0751** from 8 AM to 6 PM (EST) Monday through Friday. You can also visit us on-line at **www.powerwheels.com**.

For your convenience, Power Wheels® maintains an **independently owned and operated** Authorized Service Center Network with more than 400 authorized service centers nationwide. The authorized service centers will repair or replace parts under warranty at no extra charge, and can perform non-warranty repairs for a minimal charge. To find the authorized service center nearest to you, visit us on-line at **www.powerwheels.com** or call **1-800-348-0751**.

www.powerwheels.com

Fisher-Price, Inc., a subsidiary of Mattel, Inc., East Aurora, New York 14052 U.S.A.
©2005 Mattel, Inc. All Rights Reserved. ® and ™ designate U.S. trademarks of Mattel, Inc.