

INSTRUCTION SHEET SPECIFICATIONS

Toy: CARS KM RAD SPRINGS MCGUEN
 Toy No.: N7990
 Part No.: 0920
 Trim Size: A4
 Folded Size: A5
 Type of Fold:
 # colors: One
 Colors: Black
 Paper Stock: White Offset
 Paper Weight: 70 lb.
 EDM No.:

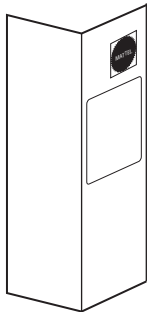

3.

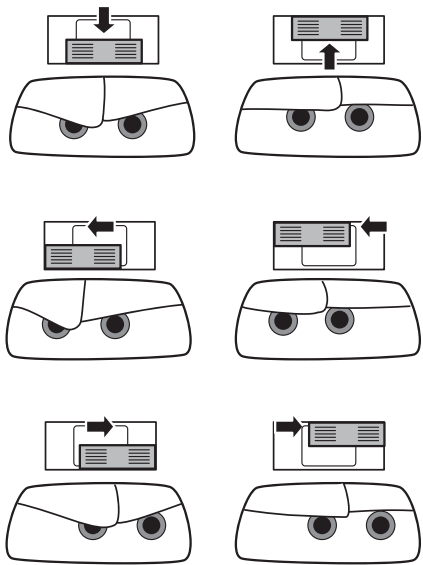
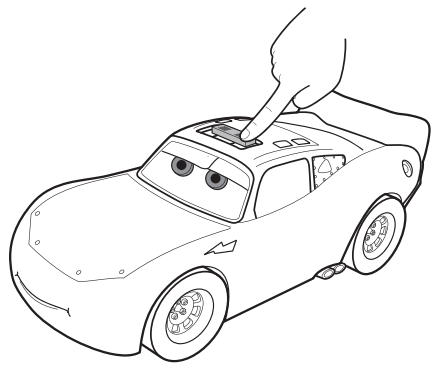

4.

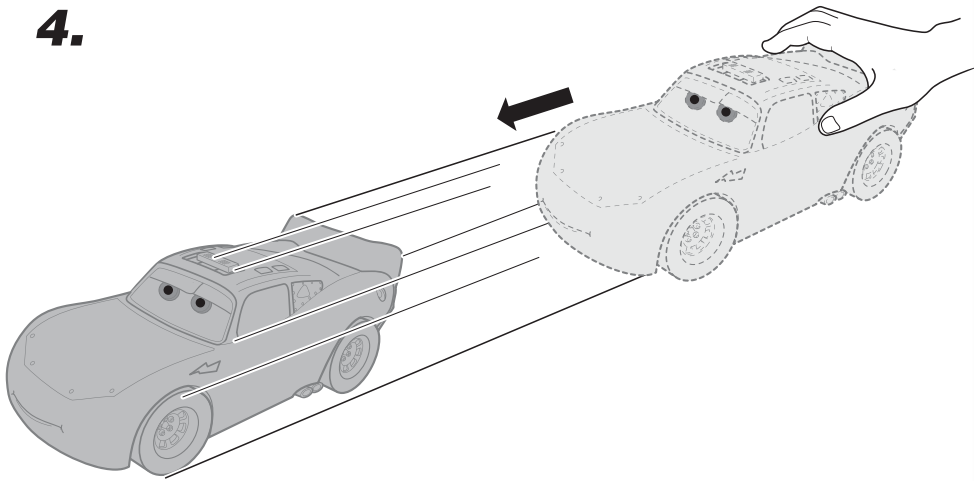

Mattel, Inc. All Rights Reserved.

Mattel, Inc., 333 Continental Blvd., El Segundo, CA 90245 U.S.A. Consumer Relations 1 (800) 524-8697. Retain this address for future reference. Mattel U.K. Ltd., Vanwall Business Park, Maidenhead SL6 4UB. Helpline 01628 500303. Mattel Australia Pty., Ltd., Richmond, Victoria. 3121. Consumer Advisory Service - 1300 135 312. Mattel East Asia Ltd., Room 1106, South Tower, World Finance Centre, Harbour City, Tsimshatsui, HK, China. Diimport & Diedarkan Oleh: Mattel SEA Ptd Ltd. (993532-P) Lot 13.5, 13th Floor, Menara Lien Hoe, Persiaran Tropicana Golf Country Resort, 47410 PJ. Tel: 03-78803817, Fax: 03-78803867.

service.mattel.com



3+

Please keep these instructions for future reference as they contain important information.

Contents

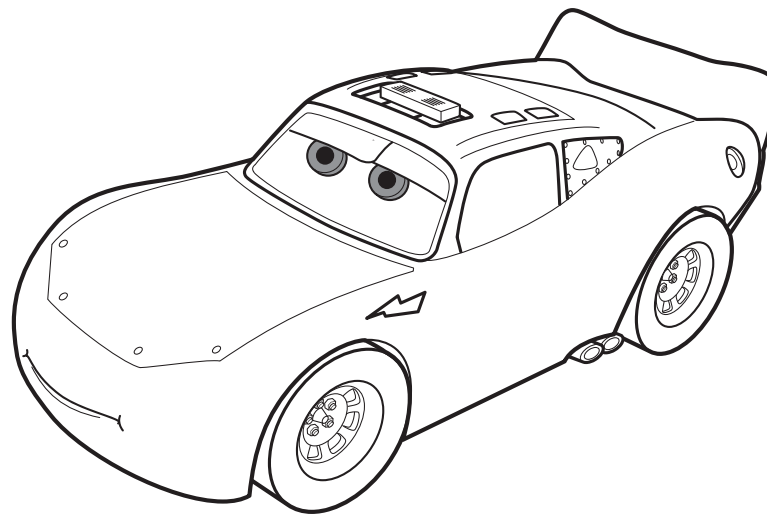

© Disney/Pixar

Battery Installation

- Unscrew the battery cover with a Phillips-head screwdriver (not included).
- Remove batteries included for demonstration purposes and dispose of them safely.
- Install 2 'AA' (LR6) alkaline batteries in the orientation shown.
- Replace the battery cover and tighten screw.
- For longer life, use only alkaline batteries.
- Replace batteries if lights dim or if sounds play slowly or distort.

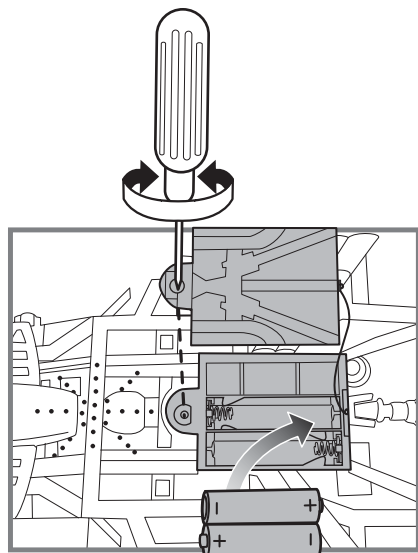

BATTERY SAFETY INFORMATION

In exceptional circumstances batteries may leak fluids that can cause a chemical burn injury or ruin your product. To avoid battery leakage:

- Non-rechargeable batteries are not to be recharged.
- Rechargeable batteries are to be removed from the product before being charged (if designed to be removable).
- Rechargeable batteries are only to be charged under adult supervision (if designed to be removable).
- Do not mix alkaline, standard (carbon-zinc), or rechargeable (nickel-cadmium) batteries.
- Do not mix old and new batteries.
- Only batteries of the same or equivalent type as recommended are to be used.
- Batteries are to be inserted with the correct polarity.
- Exhausted batteries are to be removed from the product.
- The supply terminals are not to be short-circuited.
- Dispose of battery(ies) safely.
- Do not dispose of this product in a fire. The batteries inside may explode or leak.



Protect the environment by not disposing of this product with household waste (2002/96/EC). Check your local authority for recycling advice and facilities.

To Play

1.

I = ON
O = OFF

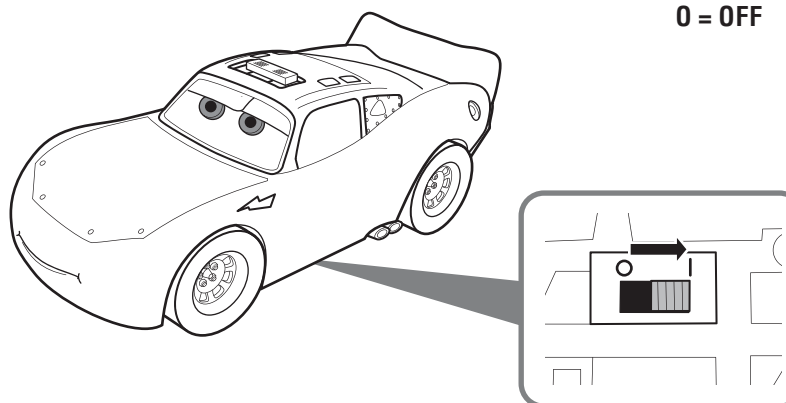

2. LIGHTS & SOUNDS

