



Owner's Manual with Assembly Instructions

For Model V4100



Product features may vary from the picture above.

Please read this manual and save it with your original sales receipt.

Tools needed for assembly: Phillips screwdriver and slotted screwdriver (tools not included).

Use only with a Power Wheels® 6 Volt (4.0 Amp/Hr.) Rechargeable Battery with Built-in Thermal Fuse and a Power Wheels® 6 Volt (4.0 Amp/Hr.) Charger (both included).

Requires one "AA" (LR6) **alkaline** battery (not included) for sound box operation.

IMPORTANT INFORMATION

ELECTRICAL HAZARD



DANGER

- To prevent electric shock, do not immerse in water; wipe clean with a damp cloth.



WARNING

- Battery can fall out and injure a child if vehicle tips over. Always use battery retainer.
- **PREVENT FIRE**
 - Never modify the electrical system. Alterations could cause a fire resulting in serious injury and could also ruin the electrical system.
 - Use of the wrong type battery or charger could cause a fire or explosion resulting in serious injury.
 - Use of Power Wheels® components in products other than Power Wheels® vehicles could cause overheating, fire or explosion.
- The battery must be handled by adults only. The battery is heavy and contains sulfuric acid (electrolyte). Dropping the battery could result in serious injury.
- Never allow children to charge the battery. Battery charging must be done by adults only. A child could be injured by the electricity involved in charging the battery.
- Never lift or carry the battery by the wires or connector. This can damage the battery and possibly cause a fire resulting in serious injury. Lift and carry the battery by the case only.
- Read the safety instructions on the battery.
- Examine the battery, charger and their connectors for excessive wear or damage each time you charge the battery. If damage or excessive wear is detected, do not use the charger or the battery until you have replaced the worn or damaged part.
- **HOT** motors. Handle carefully.

RIDING HAZARD



WARNING

- **Prevent Injuries and Deaths**
 - Direct Adult Supervision Required.
 - Never Ride At Night.
 - Keep Children Within Safe Riding Areas.
These areas must be:
 - Away from swimming pools and other bodies of water to prevent drownings.
 - Generally level to prevent tipovers
 - Away from steps, steep inclines, cars, roads and alleys.
 - Riding Rules
Make sure children know and follow these rules for safe driving and riding.
 - Always sit on the seat.
 - Always wear shoes.
 - Only 1 (one) rider at a time.

IMPORTANT INFORMATION

- Read this manual carefully for important safety information and operating instructions before using your vehicle. Keep this manual for future reference, as it contains important information.
- The vehicle is designed for use on grass, asphalt, and other hard surfaces; on generally level terrain; and by children 12-36 months of age and older. Do not exceed the maximum weight capacity of 40 lbs (18 kg).
- Your new vehicle requires adult assembly. Please set aside 20 minutes for assembly.
- Use this vehicle **ONLY** outdoors. Most interior flooring can be damaged by riding this vehicle indoors. Fisher-Price® will not be responsible for damage to the floor if the vehicle is used indoors.
- You must charge your battery for 18-30 hours **before you use your vehicle for the first time**. We recommend charging your battery before beginning assembly. Please see the Battery Charging section for detailed instructions.
- The battery charger is not a toy.
- Do not short circuit the battery.
- **Adults Note:** Regularly examine the charger for damage to the cord, plug, housing or other parts that may result in the risk of fire, electric shock or injury. In the event of any damage, do not use the charger until the damage has been properly repaired.
- Your Power Wheels® 6 volt battery is equipped with a built-in thermal fuse. The thermal fuse is a self-resetting safety device which automatically “trips” and shuts down operation of the vehicle if the vehicle is overloaded or the driving conditions too severe. Once a fuse has “tripped”, release the button on the steering wheel and wait approximately 25 seconds before operating the vehicle again. To avoid repeated automatic shut-downs, avoid severe driving conditions.
- If a thermal fuse in a battery continually trips under normal driving conditions, please contact your local Power Wheels® Authorized Service Center.
- To prevent damaging the motors and gears, teach your child to stop the vehicle before switching direction.
- If you have any questions about your Power Wheels® vehicle, please call our toll-free service lines at **1-800-348-0751**. Trained customer service representatives are available to take your call in English or French. Habla Español? Si usted tiene alguna pregunta ó necesita asistencia llame gratis **1-800-348-0755** para los Estados Unidos. Tenemos representantes que hablan español para atender su llamada.
- For your convenience, Power Wheels® maintains an **independently owned and operated** Authorized Service Center Network with more than 300 authorized service centers nationwide. Our authorized service centers will repair or replace parts under warranty at no extra charge, and can perform non-warranty repairs for a minimal charge. To find the authorized service center nearest you, please visit us online at **www.powerwheels.com** or call **1-800-348-0751**.
- Please visit us online at **www.powerwheels.com** to register your vehicle.

PARTS

- If you experience a problem with this product, or are missing a part, please call us at **1-800-348-0751**, rather than return this product to the store.
- Please identify all parts before assembly and save all packaging material until assembly is complete to ensure that no parts are discarded.

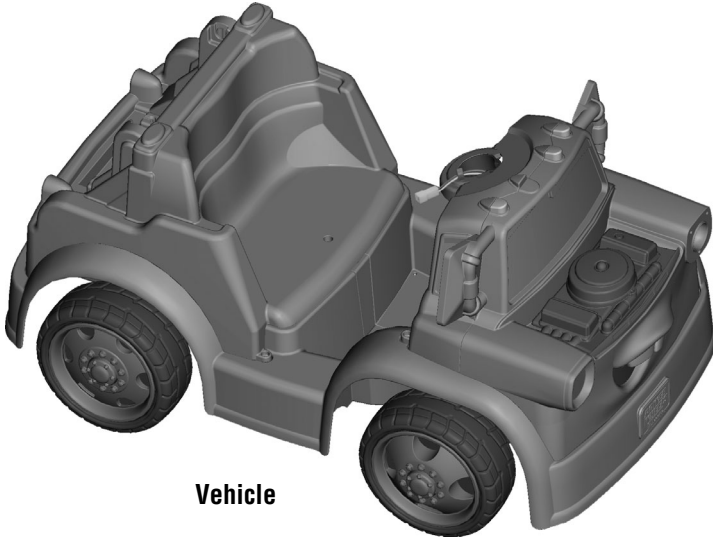

Vehicle



Steering Wheel

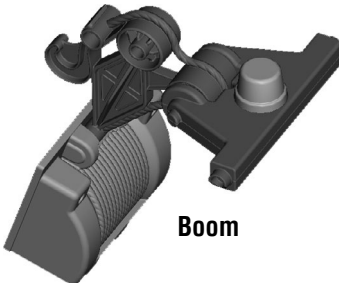

Boom



Sound Box



Steering Wheel Cover



**6 Volt (4.0 Amp/Hr.)
Battery**



**6 Volt (4.0 Amp/Hr.)
Charger**



#8 x 3/4" (1,9 cm) Screw - 1

Shown Actual Size

*Hint: For your convenience,
we've included an extra screw!*

PARTS PICTURE

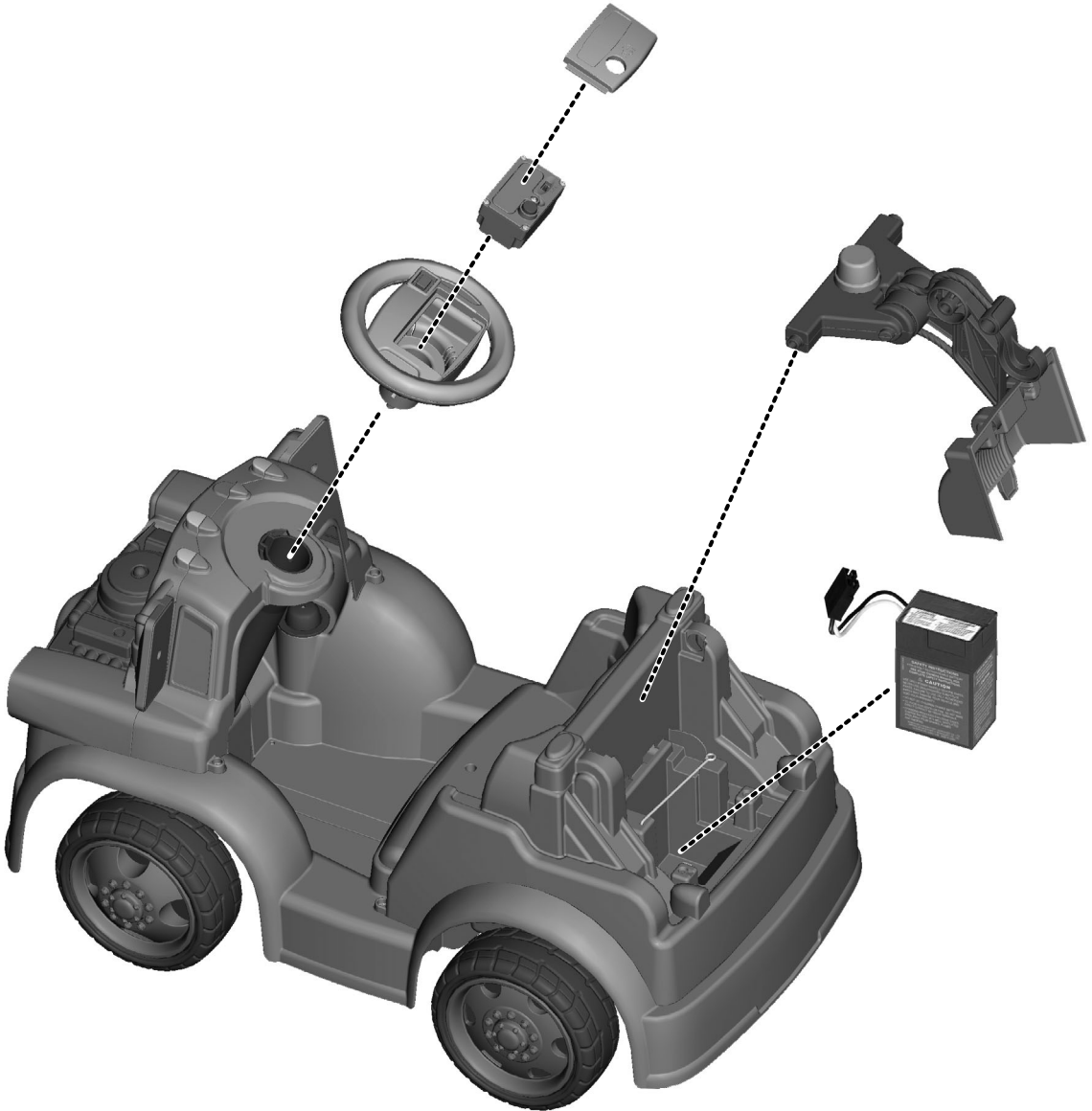

Note: Fastener not shown.

BATTERY CHARGING

ELECTRICAL HAZARD

WARNING

- Battery can fall out and injure a child if vehicle tips over. Always use battery retainer.
- **PREVENT FIRE**
 - Never modify the electrical system. Alterations could cause a fire resulting in serious injury and could also ruin the electrical system.
 - Use of the wrong type battery or charger could cause a fire or explosion resulting in serious injury.
 - Use of Power Wheels® components in products other than Power Wheels® vehicles could cause overheating, fire or explosion.
- The battery must be handled by adults only. The battery is heavy and contains sulfuric acid (electrolyte). Dropping the battery could result in serious injury.
- Never allow children to charge the battery. Battery charging must be done by adults only. A child could be injured by the electricity involved in charging the battery.
- Never lift or carry the battery by the wires or connector. This can damage the battery and possibly cause a fire resulting in serious injury. Lift and carry the battery by the case only.
- Read the safety instructions on the battery.
- Examine the battery, charger and their connectors for excessive wear or damage each time you charge the battery. If damage or excessive wear is detected, do not use the charger or the battery until you have replaced the worn or damaged part.



CAUTION

Use the charger in dry locations only.

- Make sure you charge the battery for at least 18 hours using the enclosed Power Wheels® 6 volt charger before operating your vehicle for the first time. Charge the battery for at least 14 hours after each use of the vehicle. Never charge the battery longer than 30 hours. Failure to follow these instructions may damage your battery and will void your warranty.
- Use only a Power Wheels® 6 volt (4.0 Amp/Hr.) charger with “6V” connector (input 120 VAC, 60Hz, with an output of 6 VDC) to charge your Power Wheels® 6 volt battery.

BATTERY CHARGING

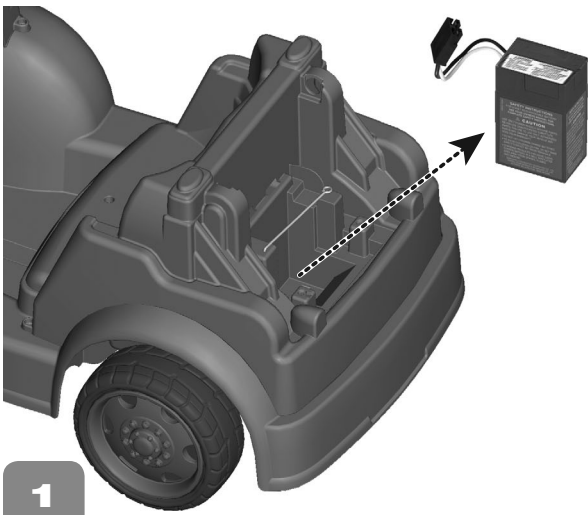

1

- Remove the #8 x 3/4" (1,9 cm) screw from the battery retainer. Lift to remove the battery retainer from the vehicle.
- Lift to remove the battery from the battery compartment.

Battery must be upright while charging.

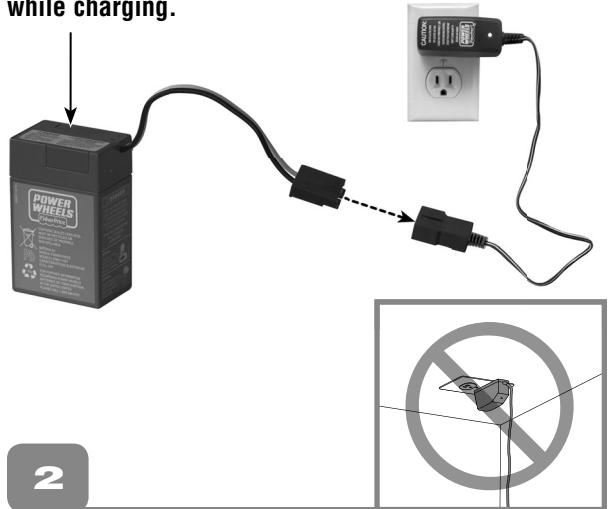

2

- Plug the battery connector into the charger connector.
- Plug the charger into a standard wall outlet.

Notes:

- If power flow to the wall outlet is controlled by a switch, make sure the switch is "ON".
- Use the charger only in a wall outlet. Do not plug the charger into a ceiling outlet.
- Once the battery is charged, disconnect the battery connector from the charger connector. Unplug the charger from the wall outlet. Refer to the Battery Installation section for instructions on installing your battery. If your battery is already installed in your vehicle, simply re-connect the motor harness connector to the battery.
- You do not need to remove the battery from your vehicle to recharge it.
- Before charging the battery, examine the battery case for cracks and other damage which may cause sulfuric acid (electrolyte) to leak during the charging process. If damage is detected, do not charge the battery or use it in your vehicle. Battery acid is very corrosive and can cause severe damage to surfaces it contacts.
- Do not place the battery on a surface (such as kitchen counter tops) which could be damaged by the acid contained inside the battery. Take precautions to protect the surface on which you place your battery.
- Charge the battery in a well ventilated area.

ASSEMBLY

WARNING

Children can be harmed by small parts, sharp edges and sharp points in the vehicle's unassembled state, or by electrical items. Care should be taken in unpacking and assembly of the vehicle. Children should not handle parts, including the battery, or help in assembly of the vehicle.

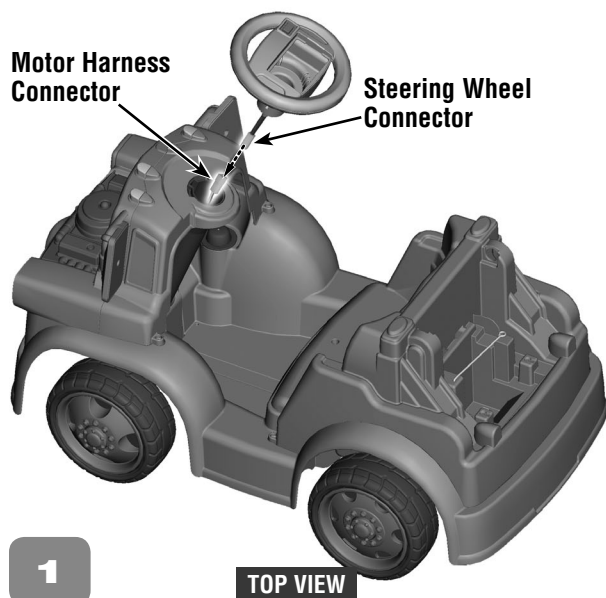

- Plug the motor harness connector to the steering wheel connector.

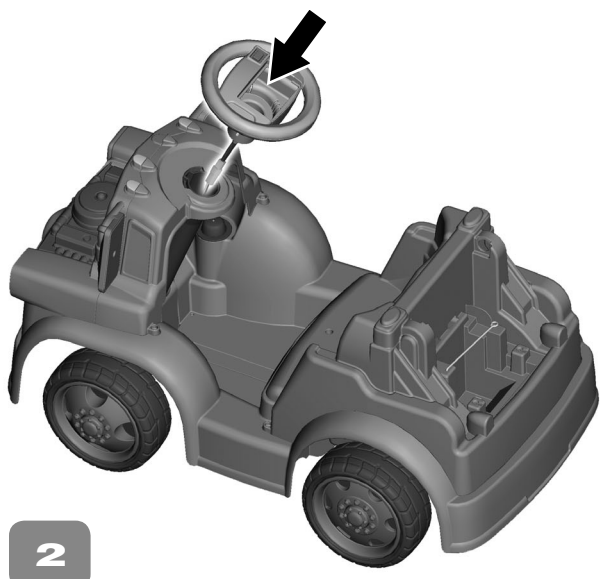

- While carefully feeding the wire down into the dash, fit the steering wheel into the dash.

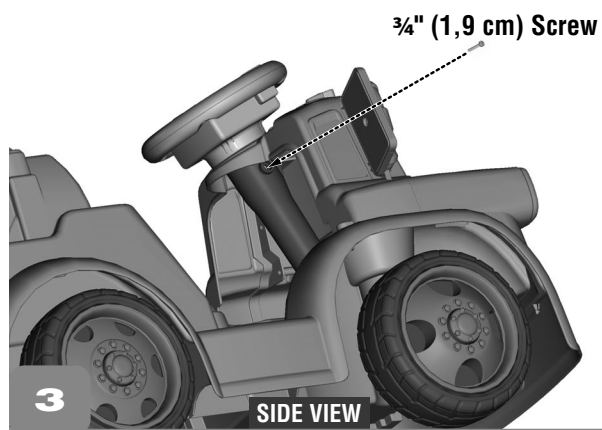

- Turn the steering wheel slightly to access the hole in the side of the steering column.
- Insert the #8 x $\frac{3}{4}$ " (1,9 cm) screw into the hole on the side of the steering column. Tighten the screw with a Phillips screwdriver. Do not over-tighten.

Hint: For your convenience, there is a hole in each side of the steering column and an extra #8 x $\frac{3}{4}$ " (1,9 cm) screw. You will only need to use one screw on one side of the steering column to fasten the steering wheel.

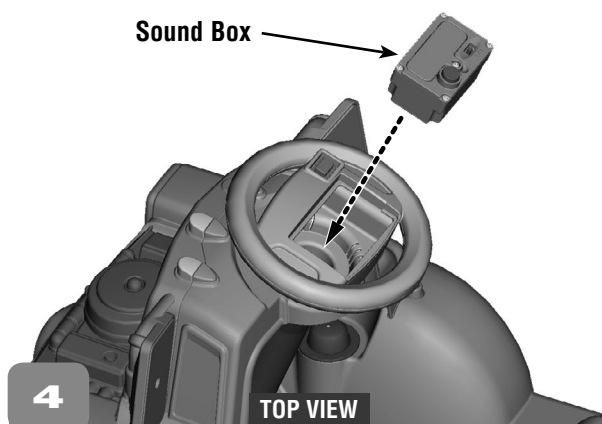

- Fit the sound box into the opening in the steering wheel.

ASSEMBLY

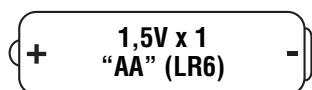

- 5**
- Loosen the screw in the battery compartment door with a Phillips screwdriver. Remove the door.
 - Insert a "AA" (LR6) **alkaline** battery.
- Hint: We recommend using an **alkaline** battery for longer battery life.*
- Replace the battery compartment door and tighten the screw.
 - When sounds become faint or stop, it's time for an adult to change the battery.

-
- Protect the environment by not disposing of this product with household waste (2002/96/EC). Check your local authority for recycling advice and facilities (Europe only).

Battery Safety Information

In exceptional circumstances, batteries may leak fluids that can cause a chemical burn injury or ruin your product. To avoid battery leakage:

- Do not mix old and new batteries or batteries of different types: alkaline, standard (carbon-zinc) or rechargeable (nickel-cadmium).
- Insert batteries as indicated inside the battery compartment.
- Remove batteries during long periods of non-use. Always remove exhausted batteries from the product. Dispose of batteries safely. Do not dispose of this product in a fire. The batteries inside may explode or leak.
- Never short-circuit the battery terminals.
- Use only batteries of the same or equivalent type as recommended.
- Do not charge non-rechargeable batteries.
- Remove rechargeable batteries from the product before charging.
- If removable, rechargeable batteries are used, they are only to be charged under adult supervision.

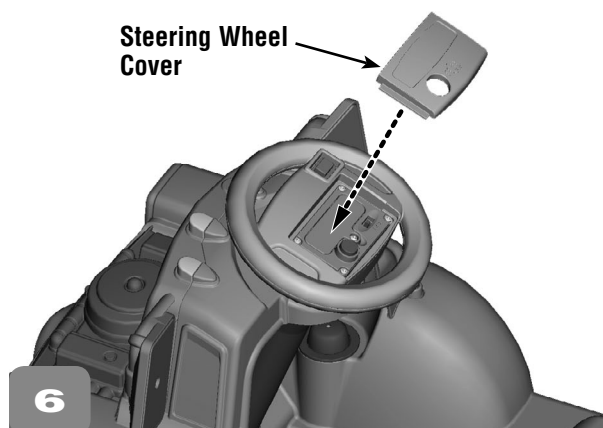

- 6**
- Fit the steering wheel cover on the steering wheel and push to "snap" in place.

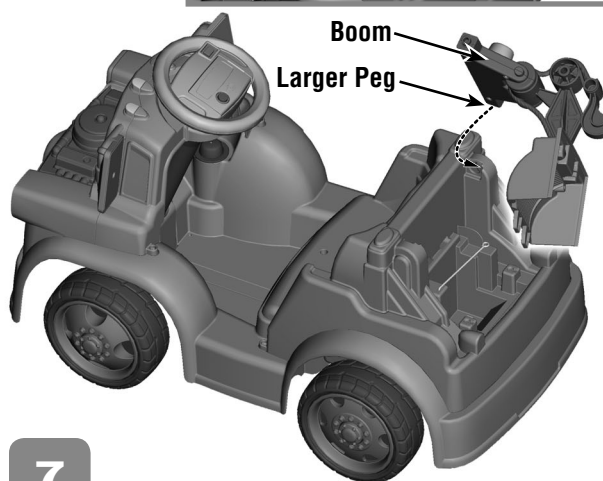
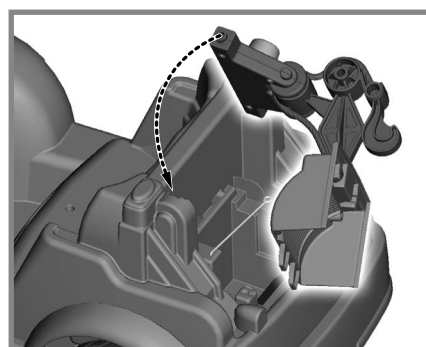

- 7**
- At an angle, fit the larger peg on the boom into the opening on the back of the vehicle.
 - Push to "snap" the peg on the side of the boom in place.

Hint: The boom is designed to fit one way. If it does not seem to fit, turn it around and try again.

DECORATION

- Wipe the vehicle with a clean, dry cloth to remove any oils before applying labels.
- Apply labels exactly as shown in the illustrations. For best results, avoid repositioning the label after it has been applied.
- Starting at the center of a label rub firmly with a dry cloth, and smooth towards the outer edges to remove air bubbles.

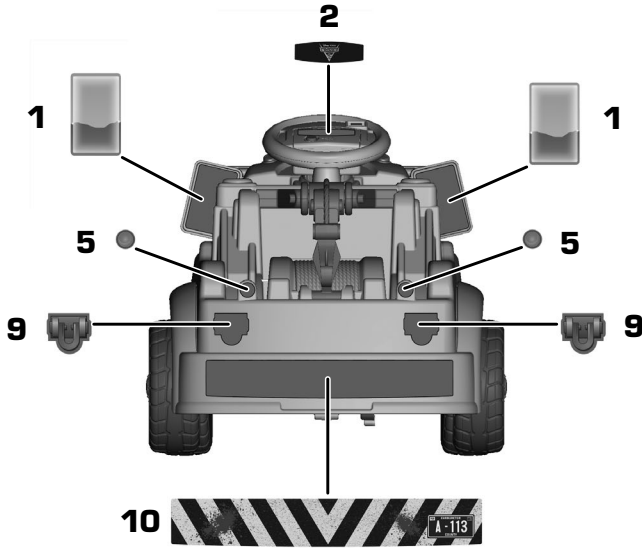

BACK VIEW

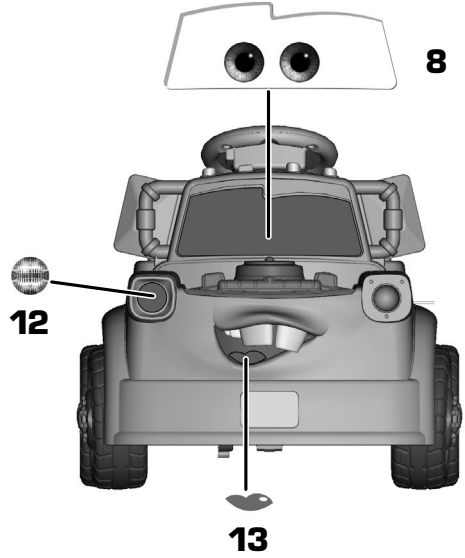

FRONT VIEW

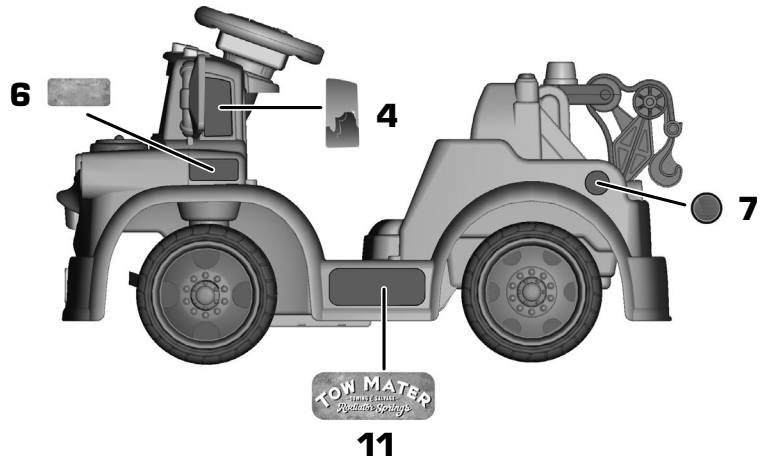

LEFT VIEW

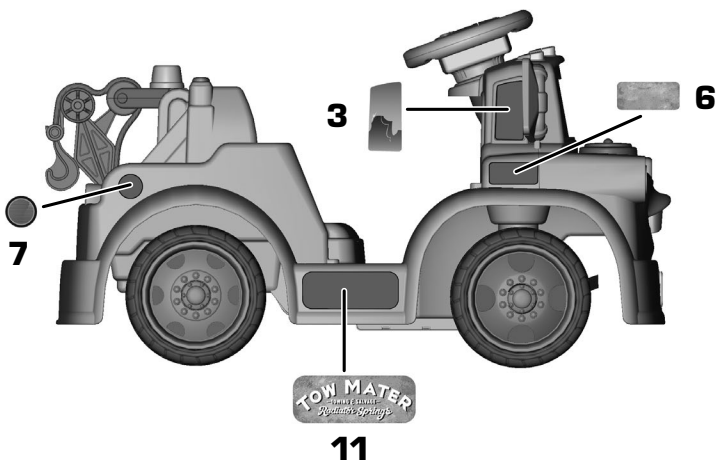

RIGHT VIEW

BATTERY INSTALLATION

IMPORTANT! Use only a Power Wheels® 6 volt (4.0 Amp/Hr) rechargeable battery. Use of any other battery will damage your vehicle.

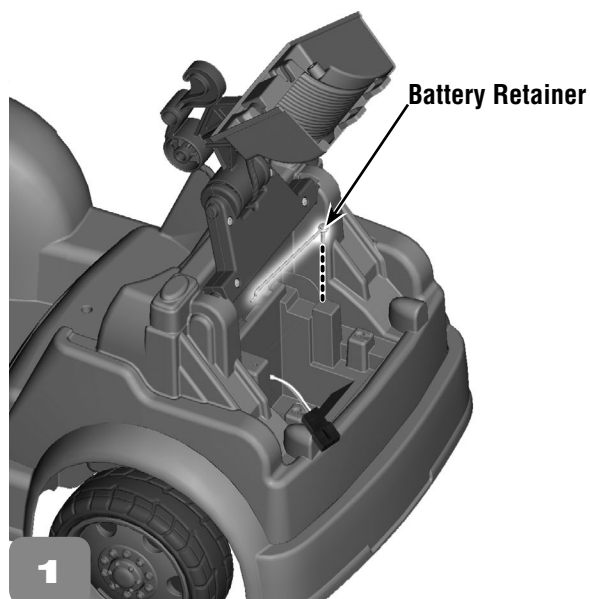

- Remove the #8 x $\frac{3}{4}$ " (1,9 cm) screw from the battery retainer. Lift to remove the battery retainer from the vehicle.

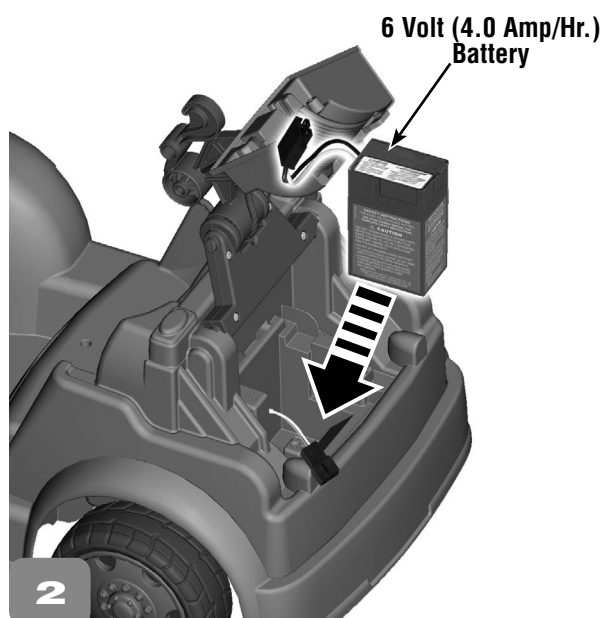

- Place the Power Wheels® 6 Volt (4.0 Amp/Hr.) battery in the battery compartment. Make sure the battery connector extends toward the rear of the vehicle.

BATTERY INSTALLATION

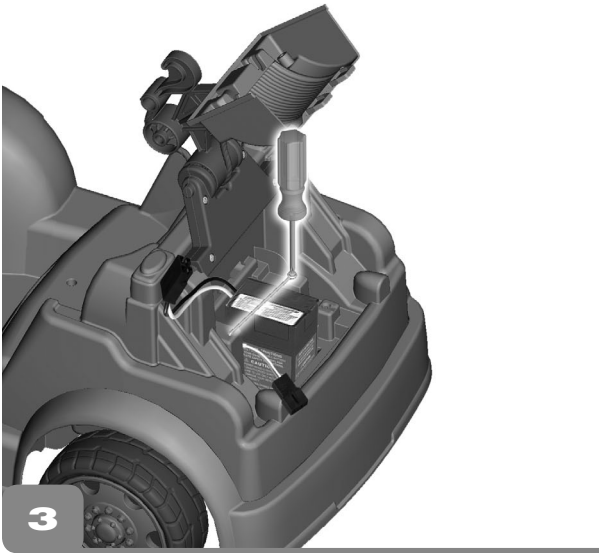

- Replace the battery retainer over the battery. Insert the #8 x 3/4" screw through the battery retainer and into the vehicle. Tighten the screw.

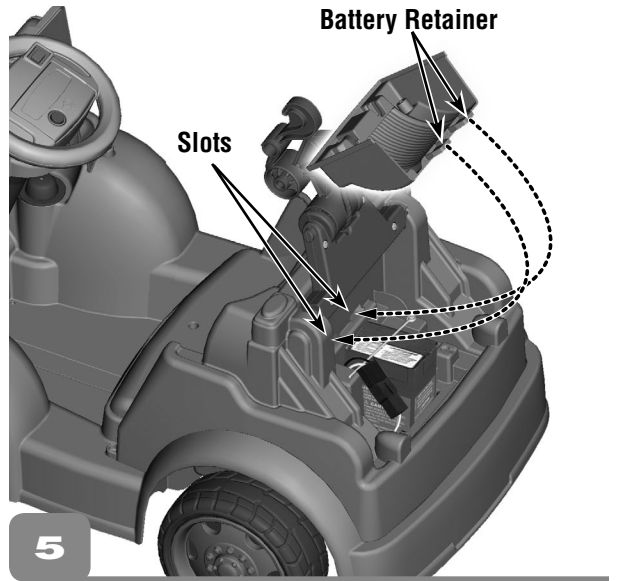

- Fit the tabs on the battery cover into the slots in the vehicle.

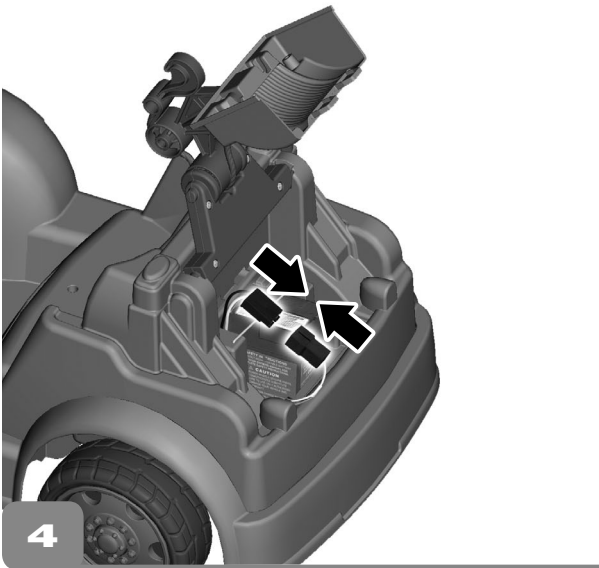

- Plug the battery connector into the motor harness connector.

Note: If the battery connector will not plug into the motor harness connector, turn it over and try again! Do not force the battery connector into the motor harness connector.

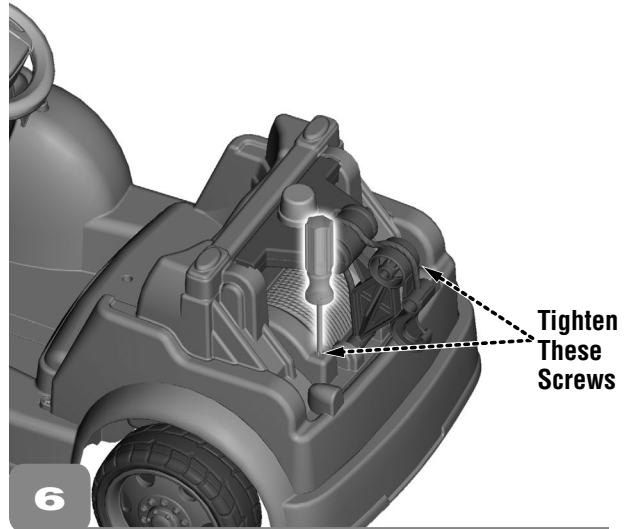

- Tighten the screws in the battery cover with a Phillips screwdriver.

IMPORTANT! Always remember to keep the fasteners tightened at all times to prevent children from accessing the battery.

BATTERY CARE

If a battery leak develops, avoid contact with the leaking acid and place the damaged battery in a plastic bag. See next section for proper disposal.

If acid comes in contact with skin or eyes, flush with cool water for at least 15 minutes and call a physician.

If acid is internally ingested, give water, milk of magnesia or egg whites immediately. Never give emetics or induce vomiting. Call a physician.

- Do not allow the battery to run down completely before charging.
- Charge the battery before storing the vehicle, and at least once per month, even if the vehicle has not been used.
- Charge the battery after each use, regardless of how long the vehicle was used.
- Leaving the battery in a discharged condition will ruin it.
- Always remove an exhausted battery from the vehicle. Battery leakage and corrosion can damage the vehicle.
- Do not store the battery in temperatures above 75° F or below -10° F.

BATTERY DISPOSAL

- Your Power Wheels® battery is a non-spillable sealed lead-acid battery. It must be recycled or disposed of in an environmentally sound manner.
- Do not dispose of a lead-acid battery in a fire. The battery may explode or leak.
- Do not dispose of a lead-acid battery in your regular, household trash. The incineration, landfilling or mixing of sealed lead-acid batteries with household trash is prohibited by law in most areas.
- Protect the environment by not disposing of this product with household waste (2002/96/EC). Check your local authority for recycling advice and facilities (Europe only).
- Return an exhausted battery to a federal or state approved lead-acid battery recycler, such as a Power Wheels® authorized service center or a local seller of automotive batteries. For the authorized service center location nearest to you, please visit us online at www.powerwheels.com or call **1-800-348-0751**. Contact your local waste management officials for other information regarding the environmentally sound collection, recycling and disposal of lead-acid batteries. If you live in the State of Florida or the State of Minnesota, it is prohibited by law for anyone to throw away lead-acid batteries in the municipal waste stream.

VEHICLE CARE

- Check all screws and their protective coverings regularly and tighten as required. Check plastic parts on a regular basis for cracks or broken pieces.
- During snowy or rainy weather, the vehicle should be stored inside or under a protective cover.
- Avoid operating the vehicle in wet or snowy conditions, and do not spray the vehicle with a hose. Water or moisture in the motors or electrical switches can cause them to corrode, and could cause switch or motor failure.
- Avoid operating the vehicle on sand, loose dirt or gravel. Sand, loose dirt or gravel in the motors or electrical switches can cause them to jam, and could cause switch or motor failure.
- The vehicle can be wiped down with a soft, dry cloth. For a shiny finish, you can wipe plastic parts with a non-wax furniture polish applied to a soft cloth. Do not use automotive wax. Do not use soap and water or spray the vehicle with a hose.
- To ensure your vehicle stays in good operating order, we recommend you periodically have your vehicle checked by a Power Wheels® authorized service center.

SAFE DRIVING RULES

RIDING HAZARD



WARNING

- **Prevent Injuries and Deaths**

- Direct Adult Supervision Required.
- Never Ride At Night.
- Keep Children Within Safe Riding Areas.

These areas must be:

- away from swimming pools and other bodies of water to prevent drownings
- generally level to prevent tipovers
- away from steps, steep inclines, cars, roads and alleys.

- **Riding Rules**

Make sure children know and follow these rules for safe driving and riding.

- Always sit on the seat.
- Always wear shoes.
- Only 1 (one) rider at a time.

Before children use this vehicle, an adult should carefully evaluate the driving area as well as the child's skill level and ability to drive the vehicle safely. Teach appropriate safety rules to your child before allowing operation of this vehicle. These rules should also be reviewed with other playmates who want to drive the vehicle.

- A child who is not sitting on the seat could fall off, cause a tip over or block the driver's view.
- Only operate the vehicle in the daytime in a well-lit area.
- Driving near steep inclines can cause:
 - The vehicle to gain unsafe speed, even if the button is released to stop.
 - The vehicle to tilt and tip over
 - The wheels to lose traction, causing the vehicle to slip.
 - The vehicle could roll backwards at an unsafe speed.
- Never put anything near any moving parts. Rotating parts, such as motors, gear boxes and wheels, can snag fingers, hair, etc., causing serious injury.
- Do not allow operation of the vehicle when it is on its side or in an upside-down position.
- Do not operate the vehicle near flammable vapors (gasoline, paint thinner, acetone, liquid wax, etc.). The vehicle's electrical switches, like most electrical switches, emit an internal spark when first turned on or turned off, which could cause an explosion or fire.
- To prevent unsupervised use of the vehicle, disconnect the motor harness from the battery when the vehicle is not in use.

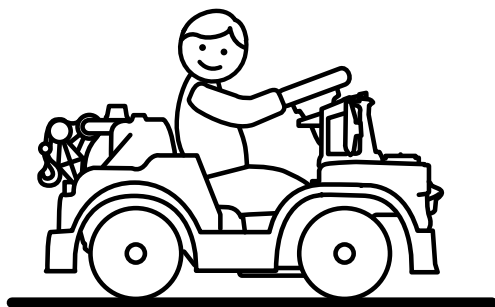

Use vehicle on generally level ground ONLY!

VEHICLE OPERATION

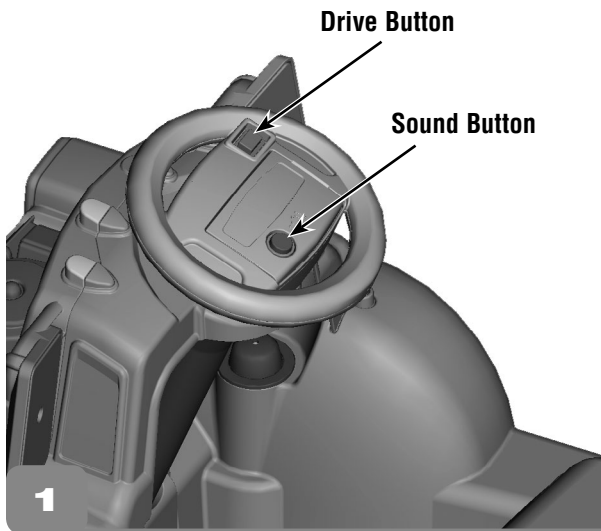

- Press the drive button on the steering wheel. The vehicle drives forward at a maximum speed of 2 mph.
- Help your child practice steering to learn how far and how quickly to turn the steering wheel when driving.
- To stop, release the drive button.
- Make sure your child is comfortable with steering the vehicle and automatically knows how to stop.
- Press the sound button for sounds/phrases. To change the mode to English, Spanish or sounds only, refer to steps 2 and 3 on this page.

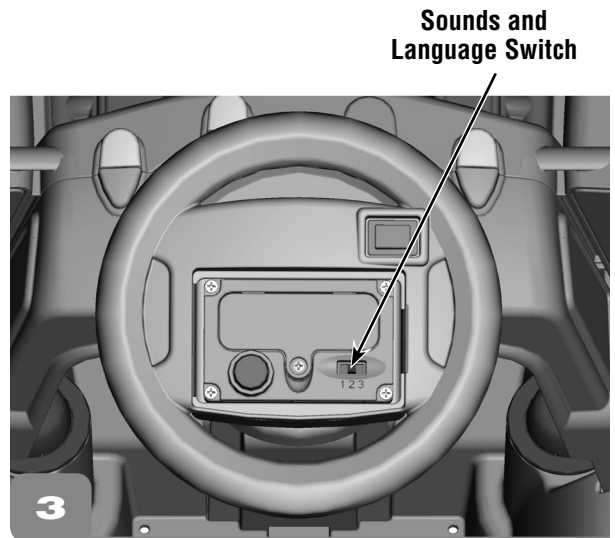

- Slide the sounds and language switch to: **1** for engine sounds; **2** for Spanish and engine sounds; or **3** for English and engine sounds.
- Carefully replace the steering wheel cover and push to snap in place.

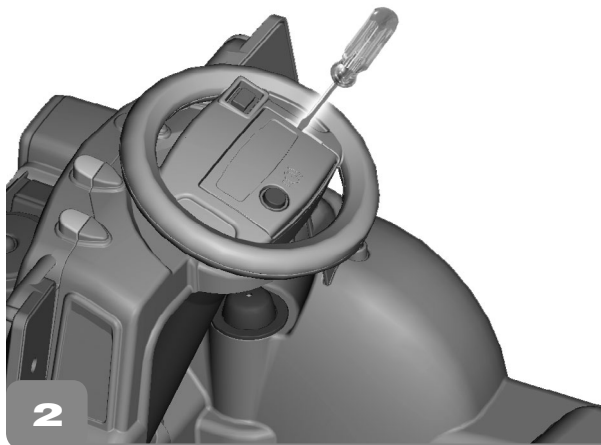

- Fit a slotted screwdriver into the slot on the steering wheel, as shown.
- Carefully remove the steering wheel cover from the steering wheel.

LIMITED WARRANTY

Bumper-to-Bumper* Limited Warranty

***One year limited warranty from the date of purchase on the Power Wheels® vehicle.**

Six month limited warranty on the 6 volt battery.

For the original purchaser, this one year limited warranty covers the Power Wheels® ride-on vehicle (purchased from Power Wheels®) against defects in materials and workmanship. The six month limited warranty applies only to the 6 volt battery included by Power Wheels® with the original purchase of the vehicle.

This warranty covers normal use and does not cover the Power Wheels® vehicle or battery if damaged by unreasonable use, neglect, accident, abuse, misuse, improper service or other causes not arising out of defects in materials or workmanship. Evidence of any attempt at consumer repair will void this warranty. THIS WARRANTY DOES NOT COVER, AND IS INTENDED TO EXCLUDE, ANY LIABILITY ON THE PART OF POWER WHEELS®, WHETHER UNDER THIS WARRANTY OR IMPLIED BY LAW FOR ANY INDIRECT OR CONSEQUENTIAL DAMAGES FOR BREACH OF WARRANTY. SOME STATES DO NOT ALLOW THE EXCLUSION OR LIMITATION SO THIS LIMITATION MAY NOT APPLY TO YOU.

Should you need service or assistance with your vehicle during the warranty period, do not return the vehicle to the store. Power Wheels® has provided a nationwide network of authorized service centers. If there is not an authorized service center in your area, please visit us on-line at www.powerwheels.com or call Consumer Relations for information, **1-800-348-0751**.

This warranty gives you specific legal rights, and you may also have other rights which may vary from state to state.

PLEASE SAVE YOUR ORIGINAL SALES RECEIPT.

FCC STATEMENT

(United States Only)

This equipment has been tested and found to comply with the limits for a Class B digital device, pursuant to Part 15 of the FCC Rules. These limits are designed to provide reasonable protection against harmful interference in a residential installation. This equipment generates, uses and can radiate radio frequency energy and, if not installed and used in accordance with the instructions, may cause harmful interference to radio communications. However, there is no guarantee that interference will not occur in a particular installation. If this equipment does cause harmful interference to radio or television reception, which can be determined by turning the equipment off and on, the user is encouraged to try to correct the interference by one or more of the following measures:

- Reorient or relocate the receiving antenna.
- Increase the separation between the equipment and receiver.
- Consult the dealer or an experienced radio/TV technician for help.

Note: Changes or modifications not expressly approved by the manufacturer responsible for compliance could void the user's authority to operate the equipment.

This device complies with Part 15 of the FCC Rules. Operation is subject to the following two conditions: (1) this device may not cause harmful interference and (2) this device must accept any interference received, including interference that may cause undesired operation.

ICES-003

This Class B digital apparatus complies with Canadian ICES-003. Operation is subject to the following two conditions: (1) this device may not cause harmful interference and (2) this device must accept any interference received, including interference that may cause undesired operation.

NMB-003

Cet appareil numérique de la classe B est conforme à la norme NMB-003 du Canada. L'utilisation de ce dispositif est autorisée seulement aux conditions suivantes: (1) il ne doit pas produire de brouillage et (2) l'utilisateur du dispositif doit être prêt à accepter tout brouillage radioélectrique reçu, même si ce brouillage est susceptible de compromettre le fonctionnement du dispositif.

PROBLEMS AND SOLUTIONS GUIDE

IMPORTANT! If you experience a problem with your vehicle, first check the Problems and Solutions Guide below. If you still experience a problem, please contact Power Wheels® Consumer Relations, toll-free at **1-800-348-0751**. Or, contact your local Power Wheels® authorized service center. For the location nearest you, please visit us online at www.powerwheels.com.

PROBLEM	POSSIBLE CAUSE	SOLUTION
Vehicle does not run	Undercharged battery	Charge the battery. A new battery should have been charged for at least 18 hours before using the vehicle for the first time. After first-time use, recharge the battery for at least 14 hours after each use. Never charge the battery longer than 30 hours.
		Check all connectors. Make sure the battery connector is tightly plugged into the charger connector, and that the charger is plugged into the wall.
		Make sure power flow to the wall outlet is "ON".
	Charger is not working	There is no sure way to tell if your charger is working unless you have a volt meter. If you suspect there is a problem with your charger, contact your local Power Wheels® authorized service center. They can test your charger for you.
	Tripped thermal fuse	The built-in thermal fuse may "trip" and shut down operation of the vehicle if the vehicle is overloaded or the driving conditions too severe. Once a fuse has "tripped", release the button on the steering wheel and wait approximately 25 seconds before operating the vehicle again. To avoid repeated automatic shutdowns, do not overload the vehicle by exceeding the 40 lb (18 kg) maximum weight capacity or by towing anything behind the vehicle. Do not drive up hills or run into fixed objects, which can cause the wheels to stop spinning while power is still being supplied to the motors. If a thermal fuse continually trips, contact your local Power Wheels® authorized service center.
	Loose wires or loose connectors	Check all wires and connectors. Make sure the battery connector is tightly plugged into the motor connector and that there are no loose wires around the motors.
	Dead battery	If your battery is old or if you have not followed Battery Care instructions, your battery may be dead. If you are unsure whether or not the battery is dead, you can have it tested at your local Power Wheels® authorized service center.
	Electrical switch damage	The electrical switches can become corroded due to exposure to water or moisture, or can jam due to loose dirt, sand or gravel. Contact your local Power Wheels® authorized service center for diagnosis and repair.
Motor damage	Contact your local Power Wheels® authorized service center for diagnosis and repair.	

PROBLEMS AND SOLUTIONS GUIDE

PROBLEM	POSSIBLE CAUSE	SOLUTION
Vehicle was running but suddenly stopped	Loose wires or loose connectors	Check all wires and connectors. Make sure the battery connector is tightly plugged into the motor connector, and that there are no loose wires around the motors.
	Tripped thermal fuse	The built-in thermal fuse may "trip" and shut down operation of the vehicle if the vehicle is overloaded or the driving conditions too severe. Once a fuse has "tripped", release the button on the steering wheel and wait approximately 25 seconds before operating the vehicle again. To avoid repeated automatic shutdowns, do not overload the vehicle by exceeding the 40 lb (18 kg) maximum weight capacity or by towing anything behind the vehicle. Do not drive up hills or run into fixed objects, which can cause the wheels to stop spinning while power is still being supplied to the motors. If a thermal fuse continually trips, contact your local Power Wheels® authorized service center.
Short run time (Less than 1 - 3 hours per charge)	Undercharged battery	Charge the battery. A new battery should have been charged for at least 18 hours before using the vehicle for the first time. After first-time use, recharge the battery for at least 14 hours after each use. Never charge the battery longer than 30 hours.
		Check all wires and connectors. Make sure the battery connector is tightly plugged into the charger connector, and that the charger is plugged into the wall.
		Make sure power flow to the wall outlet is "ON".
	Overcharged battery	Do not charge the battery longer than 30 hours. If you suspect that your battery is damaged as a result of overcharging, contact your local Power Wheels® authorized service center. They can test the battery for you.
	Battery is old and will not accept full charge	Even with proper care, a rechargeable battery does not last forever. Average battery life is 1 to 3 years depending on vehicle use and use conditions. Replace only with a Power Wheels® 6 Volt (4.0 Amp/Hr.) battery with built-in thermal fuse. Do not substitute parts.
	Tripped thermal fuse	The built-in thermal fuse may "trip" and shut down operation of the vehicle if the vehicle is overloaded or the driving conditions too severe. Once a fuse has "tripped", release the button on the steering wheel and wait approximately 25 seconds before operating the vehicle again. To avoid repeated automatic shutdowns, do not overload the vehicle by exceeding the 40 lb (18 kg) maximum weight capacity or by towing anything behind the vehicle. Do not drive up hills or run into fixed objects, which can cause the wheels to stop spinning while power is still being supplied to the motors. If a thermal fuse continually trips, contact your local Power Wheels® authorized service center.

PROBLEMS AND SOLUTIONS GUIDE

PROBLEM	POSSIBLE CAUSE	SOLUTION
Vehicle runs sluggishly	Undercharged battery	Charge the battery. A new battery should have been charged for at least 18 hours before using the vehicle for the first time. After first-time use, recharge the battery for at least 14 hours after each use. Never charge the battery longer than 30 hours.
		Check all connectors. Make sure the battery connector is tightly plugged into the charger connector, and that the charger is plugged into the wall.
		Make sure power flow to the wall outlet is "ON".
	Battery needs charging	Be sure to charge the battery after each use.
	Battery is old and will not accept full charge	Even with proper care, a rechargeable battery does not last forever. Average battery life is 1 to 3 years depending on vehicle use and use conditions. Replace only with a Power Wheels® 6 Volt (4.0 Amp/Hr.) battery with built-in thermal fuse. Do not substitute parts.
	Vehicle is overloaded	Make sure you do not overload the vehicle by allowing more than one rider at one time, exceeding the 40 lb (18 kg) maximum weight capacity, or by towing objects behind the vehicle.
Sometimes the vehicle doesn't run, but other times it does	Driving conditions are too stressful	Use only on generally level ground.
	Loose wire or connector	Check all wires around the motors and all connectors to make sure they are tight.
When the button is pressed, the vehicle won't run without a push	Motor or electrical switch damage	Contact your local Power Wheels® authorized service center for diagnosis and repair.
	Loose wire or connector	Check all wires around the motors and all connectors to make sure they are tight.
Battery's thermal fuse constantly "trips", but the vehicle is not overloaded nor the driving conditions too severe	"Dead Spot" on motor	Contact your local Power Wheels® authorized service center for diagnosis and repair.
	Damaged battery	Contact your local Power Wheels® authorized service center for diagnosis and repair.
Loud clacking or grinding noise from a motor-gearbox	Broken gears	Contact your local Power Wheels® authorized service center for diagnosis and repair.
Charger gets warm during use	It is normal for some chargers to get warm during use and is not reason for concern. Some chargers do not get warm during use.	No action required.
		If your charger does not get warm during use, it does not mean that it is not working properly.
Battery makes a sizzling or gurgling noise when charging	It is normal for some batteries to make noise and swell slightly while charging and is not reason for concern.	No action required.
		If your battery does not make noise or swell slightly during charging, it does not mean that it is not accepting the charge.
Sound from the sound box is distorted/faint /erratic or no sounds at all	Battery is weak or dead	Remove and replace the battery in the sound box with a new, "AA" (LR6) alkaline battery.
	Electronics need to be reset	Remove and replace the battery in the sound box.
I don't hear phrases from the sound box	Sound box is set to the wrong mode	Remove the steering wheel cover and slide the language switch to: 2 for Spanish and engine sounds or 3 for English and engine sounds.



**Before first-time use,
you must charge the battery
18 hours!**

Charge the battery immediately after each use.
Charge the battery once a month, even if the vehicle is not used or stored.

**Do not return
your vehicle to the store!**

We're a toll-free phone call away, and we can help.
If you are missing parts or need assistance, please call:

1-800-348-0751

Or contact your local **independently owned and operated**
Power Wheels® Authorized Service Center.

For the location nearest you, visit us on-line at **www.powerwheels.com**.

©Disney/Pixar

Visit the Disney website at www.disney.com

Fisher-Price, Inc., a subsidiary of Mattel, Inc., East Aurora, New York 14052 U.S.A.

©2011 Mattel, Inc. All Rights Reserved. ® and ™ designate U.S. trademarks of Mattel, Inc. unless otherwise indicated.