

# HOT WHEELS RC

## NITRO SPEEDERS™

8+



Asst. T9541

T9542/X1445/W0464/W0465-0920

Keep these instructions for future reference as they contain important information. **IMPORTANT:** Please read all "Consumer Information" before operating your vehicle.

**CAUTION:** To prevent entanglement, keep all hair away from the wheels.

**CAUTION:** Surfaces may become hot and cause burns if electronics get wet. Do not operate vehicle through water or snow.

### I. CONTENTS/ FEATURES

This set includes: 1 Vehicle, 1 Transmitter

- 1 Forward / Reverse
- 2 Left / Right
- 3 Battery cover
- 4 ON (I) / OFF (O)
- 5 CHARGER (4) / OFF (O) / ON (I)
- 6 Steering adjuster button - Adjust, if necessary, to keep vehicle running straight.
- 7 Red LED
- 8 Green LED

**NOTE:**

Vehicle powered by permanently installed Li-Po battery and transmitter requires 4 AA alkaline batteries, not included.

For hassle-free racing, each vehicle has a designated racing channel (Camaro® "A" / Fiesta "B" / Mustang "C"). To race your friends, choose two vehicles with different channel designations.

PLEASE NOTE: Vehicles running on the same channel cannot race together.

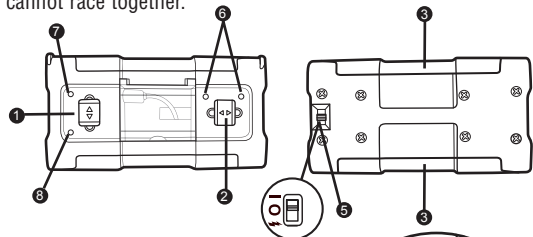

**NOTE:** If tires detach, simply line up the hole in the tire with the wheel base and push the tire back into place to continue play.

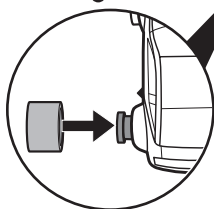

W0464 Chevy® Camaro®

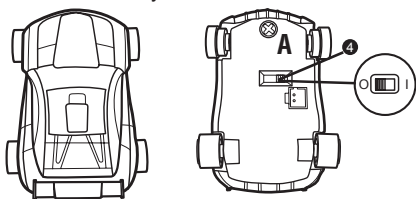

W0465 Ken Block Ford Fiesta

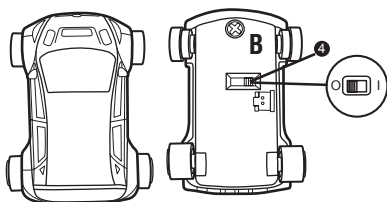

T9542 / X1445 Ford Mustang GT

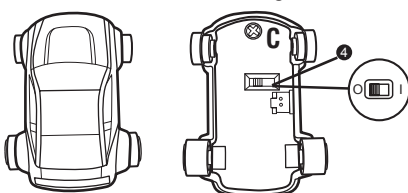

## II. BATTERY INSTALLATION

### (Transmitter)

Requires 4 AA alkaline batteries for the transmitter, not included.

#### Transmitter

1. Unscrew the battery cover with a Phillips head screwdriver (not included).
2. Install 4 AA alkaline batteries with polarity (+/-) as shown inside the battery compartment.
3. Replace battery covers and tighten screws.

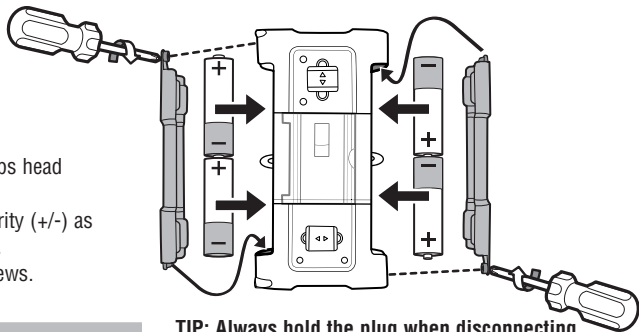

## III. CHARGING THE VEHICLE

Your vehicle is powered by a Li-Po battery that is permanently installed. The vehicle must be charged before play. To charge, first make sure you have installed 4 AA alkaline batteries in the transmitter as shown in Section II. Then follow these easy steps.

1. Make sure the switch on both the transmitter and vehicle are in the OFF position.
2. Open door on transmitter, hold plug and pull out charger cable (See a).
3. Connect plug to vehicle. Make sure the connection is secure (See b).
4. To begin charging, move the switch on the transmitter from OFF to CHARGER. Both the Red and Green LEDs light up when charging (See c).
5. The charging process takes up to 25 minutes. Green LED goes off when charging is complete.
6. When fully charged, remove the charger cable from the vehicle.

**TIP:** Always hold the plug when disconnecting. NEVER pull on the cable to disconnect; this may cause the cable to break.

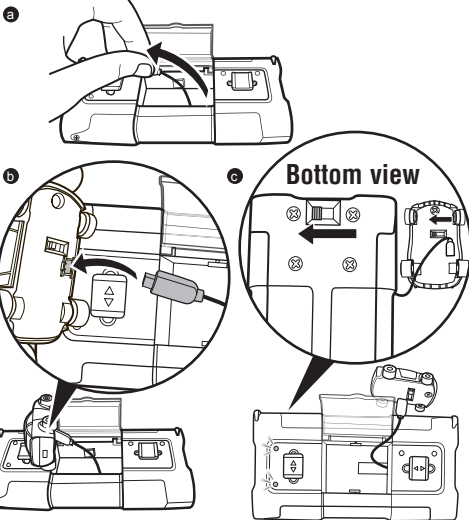

## IV. OPERATION

Infra-red LED in Transmitter needs to point towards vehicle during play. If your vehicle doesn't respond when the Transmitter is activated, make sure the LEDs are pointing at the vehicle.

Turn vehicle and transmitter ON to play.

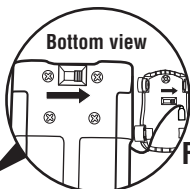

**FORWARD**

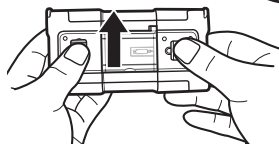

**REVERSE**

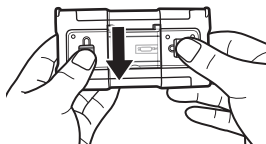

**FORWARD LEFT**

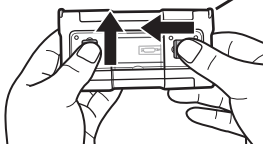

**REVERSE LEFT**

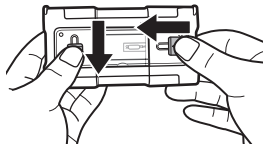

**FORWARD RIGHT**

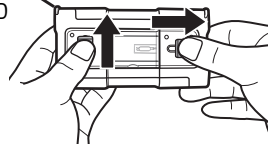

**REVERSE RIGHT**

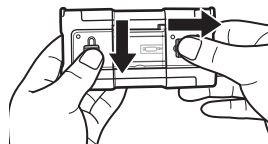

#### IMPORTANT:

- Do not cover up the infra-red LEDs with your fingers.
- Works best on flat, level, hard surfaces.
- This product is not recommended for use on carpet, loose dirt or wet surfaces.

## V. STEERING ADJUSTMENT

Each steering adjuster button has three settings. If vehicle veers right, press the left steering adjuster button repeatedly to cycle through each setting and stop when the vehicle returns to running in a straight line. Use the right steering adjuster button if the vehicle veers left.

## VI. QUICK TIPS

- 1 When your vehicle starts to lose power, it may lose functionality or performance. It's time for fresh batteries. Your vehicle's running time varies depending on your driving style.
- 2 Interference can affect your vehicle's performance. Interference can be caused by other I/R devices like a TV remote control or other remotes in the house. Try to stay away from these!
- 3 Point the transmitter toward the vehicle. If your vehicle gets too far away, it won't work properly.
- 4 Don't drive your vehicle in sand or through water or snow. If your vehicle does get wet, wipe it with a towel and allow to dry completely overnight.
- 5 Don't store your vehicle near heat or in direct sunlight. Always turn switches OFF and remove all batteries for storage.
- 6 Do not obstruct the line of sight.
- 7 Do not exceed the specified range.
- 8 This vehicle works better indoors than outdoors where sunlight can sometimes interfere with the I/R.
- 9 If the vehicle malfunctions, please turn the vehicle's power OFF and ON again. This should reset your vehicle and let you resume normal operation.

## VII. BATTERY SAFETY INFORMATION

In exceptional circumstances batteries may leak fluids that can cause a chemical burn injury or ruin your product. To avoid battery leakage:

- Non-rechargeable batteries are not to be recharged.
- Rechargeable batteries are to be removed from the product before being charged (if designed to be removable).
- Rechargeable batteries are only to be charged under adult supervision (if designed to be removable).
- Do not mix alkaline, standard (carbon-zinc), or rechargeable (nickel-cadmium) batteries.
- Do not mix old and new batteries.
- Only batteries of the same or equivalent type as recommended are to be used.
- Batteries are to be inserted with the correct polarity.
- Exhausted batteries are to be removed from the product.
- The supply terminals are not to be short-circuited.
- Dispose of battery(ies) safely.
- Do not dispose of this product in a fire. The batteries inside may explode or leak.

### Battery Performance Note:

For best performance use regular or high-performance alkaline batteries (where disposable batteries are called for). Battery life may vary depending on battery brand.

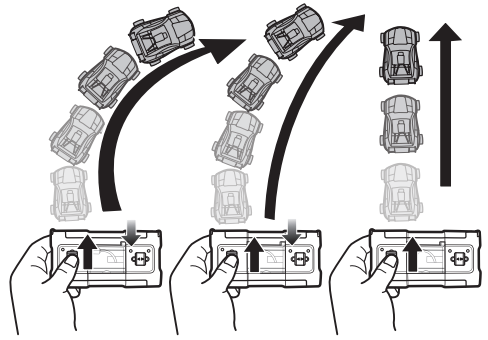

### IMPORTANT INFORMATION:

- DO NOT RECHARGE THE VEHICLE IF IT FEELS HOT. ALLOW IT TO COOL BEFORE RECHARGING.
- DO NOT ATTEMPT TO USE OR CHARGE THE VEHICLE IF IT SHOWS SIGNS OF LEAKAGE OR CORROSION.
- DO NOT DISASSEMBLE THE VEHICLE'S PERMANENTLY INSTALLED Li-Po (Lithium Polymer) BATTERY. THE Li-Po BATTERY IS A SEALED Li-Po BATTERY.
- IF THE VEHICLE AND/OR TRANSMITTER ARE WET, THOROUGHLY DRY BEFORE USING OR CHARGING.
- REGULARLY EXAMINE ALL WIRES AND CONNECTORS. IN THE EVENT OF DAMAGE, DO NOT USE.
- REPLACE BATTERIES IN TRANSMITTER IF TIME TO RECHARGE THE VEHICLE EXCEEDS 35 MINUTES.

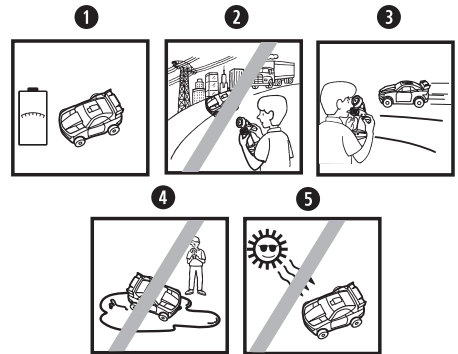

## VIII. CONSUMER INFORMATION

Note to Adults: To ensure that the child's play is both safe and fun, please review all operating instructions and safety rules with your child.

### Safety Tips

- Vehicle is to be charged using only the charger base supplied. Do not charge the Li-Po vehicle battery in any other battery charger.
- NEVER drive your vehicle on streets! They're for real cars!
- DO NOT pick up the vehicle while in motion.
- Keep fingers, hair and loose clothing away from the tires and the wheel hubs while the vehicle is switched ON.
- Adult supervision is recommended when this vehicle is being operated.
- To avoid accidental operation, remove all batteries when not in use.



Protect the environment by not disposing of this product with household waste (2002/96/EC). Check your local authority for recycling advice and facilities.

© 2011 Mattel, Inc. All Rights Reserved.  
Mattel, Inc., 636 Girard Avenue, East Aurora, NY 14052, U.S.A. Consumer Relations 1-888-557-8926.  
• Mattel U.K. Ltd., Vanwall Business Park, Maidenhead SL6 4UB. Helpline 01628 500303. • Mattel Australia Pty., Ltd., Richmond, Victoria. 3121. Consumer Advisory Service - 1300 135 312. • Mattel East Asia Ltd., Room 1106, South Tower, World Finance Centre, Harbour City, Tsimshatsui, HK, China. • Diimport & Diedarkan Oleh: Mattel SEA Ptd Ltd.(993532-P) Lot 13.5, 13th Floor, Menara Lien Hoe, Persiaran Tropicana Golf Country Resort, 47410 PJ. Tel:03-78803817, Fax:03-78803867. service.mattel.com



Ford Oval and nameplates are registered trademarks owned and licensed by Ford Motor Company.

[www.ford.com](http://www.ford.com)

Chevrolet, Chevy, the Bowtie Emblem, Camaro, all related Emblems, and the related vehicle body designs are General Motors Trademarks used under license to Mattel, Inc.

All commercial and publicity rights to use or market the name and likeness of 'Ken Block' are licensed exclusively through the Wasserman Media Group, LLC.

**This device complies with Part 15 of the FCC Rules.**

**Operation is subject to the following two conditions:**

(1) This device may not cause harmful interference, and  
(2) this device must accept any interference received, including interference that may cause undesired operation.

- This equipment has been tested and found to comply with the limits for a Class B digital device, pursuant to part 15 of the FCC rules. These limits are designed to provide reasonable protection against harmful interference in a residential installation. This equipment generates, uses and can radiate radio frequency energy and, if not installed and used in accordance with the instructions, may cause harmful interference to radio communications. However, there is no guarantee that interference will not occur in a particular installation. If this equipment does cause harmful interference to radio or television reception, which can be determined by turning the equipment off and on, the user is encouraged to try to correct the interference by one or more of the following measures:
- Reorient or relocate the receiving antenna.
- Increase the separation between the equipment and receiver.
- Connect the equipment into an outlet on a circuit different from that to which the receiver is connected.
- Consult the dealer or an experienced radio/TV technician for help.

**NOTE:** Changes or modifications not expressly approved by the manufacturer responsible for compliance could void the user's authority to operate the equipment.