

This is a battery-operated product.
1 flyer (00001-2908G8) is required
to be placed inside the packaging.

For product sold in USA

This device complies with Part 15 of the FCC Rules.

Operation is subject to the following two conditions:

- (1) This device may not cause harmful interference, and (2) this device must accept any interference received, including interference that may cause undesired operation.
- This equipment has been tested and found to comply with the limits for a Class B digital device, pursuant to part 15 of the FCC rules. These limits are designed to provide reasonable protection against harmful interference in a residential installation. This equipment generates, uses and can radiate radio frequency energy and, if not installed and used in accordance with the instructions, may cause harmful interference to radio communications. However, there is no guarantee that interference will not occur in a particular installation. If this equipment does cause harmful interference to radio or television reception, which can be determined by turning the equipment off and on, the user is encouraged to try to correct the interference by one or more of the following measures:
 - Reorient or relocate the receiving antenna.
 - Increase the separation between the equipment and receiver.
 - Connect the equipment into an outlet on a circuit different from that to which the receiver is connected.
 - Consult the dealer or an experienced radio/TV technician for help.

NOTE: Changes or modifications not expressly approved by the manufacturer responsible for compliance could void the user's authority to operate the equipment.

For product sold in Canada • Pour les produits vendus au Canada

THIS CLASS B DIGITAL APPARATUS COMPLIES WITH CANADIAN ICES-003.

CET APPAREIL NUMÉRIQUE DE LA CLASSE B EST CONFORME À LA NORME NMB-003 DU CANADA.

(VALID FOR CANADA ONLY • VALABLE AU CANADA SEULEMENT)

Operation is subject to the following two conditions :

- (1) this device may not cause interference, and (2) this device must accept any interference, including interference that may cause undesired operation of the device.

L'utilisation de ce dispositif est autorisée seulement aux conditions suivantes:

- (1) Il ne doit pas produire de brouillage et (2) il doit pouvoir tolérer tout brouillage radioélectrique reçu, même si ce brouillage est susceptible de compromettre son fonctionnement.



Protect the environment by not disposing of this product with household waste (2002/96/EC).
Check your local authority for recycling advice and facilities.

THE DARK KNIGHT RISES
L'ASCENSION DU CHEVALIER NOIR

INSTRUCTIONS MODE D'EMPLOI

4+

Please keep these instructions for future reference as they contain important information. • Conserver ce mode d'emploi pour s'y référer en cas de besoin car il contient des informations importantes.

BATTERY INSTALLATION • INSTALLATION DES PILES

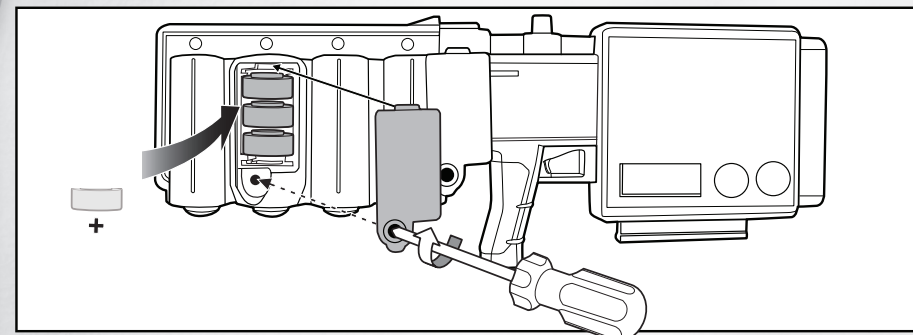

Unscrew the battery cover with a Phillips head screwdriver (not included). • Remove batteries included for demonstration purposes and dispose of them safely. Install 3 new AG13 (LR44) button cell batteries in the orientation (+/-) shown. • Replace battery cover and tighten screw. • Replace the batteries if the sounds are garbled and lights are dim.

Dévisser le couvercle du compartiment des piles avec un tournevis cruciforme (non fourni). • Retirer les piles de démonstration incluses et les jeter dans un conteneur réservé à cet usage. Insérer 3 piles boutons AG13 (LR44) neuves dans le sens (+/-) indiqué. • Remettre le couvercle et resserrer la vis. • Changer les piles si les sons sont déformés ou si les lumières faiblissent.

Do not aim at eyes or face. Only use projectiles supplied with this toy. Do not fire at point blank range • Ne pas viser les yeux ou le visage. N'utiliser que les projectiles fournis avec ce jouet. Ne pas tirer à bout portant.

WARNING:
CHOKING HAZARD - Small parts.
Not for children under 3 years.
ATTENTION:
DANGER D'ÉTOUFFEMENT - Petits éléments.
Ne convient pas aux enfants de moins de 36 mois.

©2011 Mattel, Inc. All Rights Reserved. Tous droits réservés.

Mattel, Inc. 636 Girard Avenue, East Aurora, NY 14052, U.S.A. Consumer Relations 1-800-524-8697. Mattel Canada Inc., Mississauga, Ontario L5R 3W2. You may call us free at 1-800-524-8697. Mattel Australia Pty., Ltd., Richmond, Victoria. 3121. Consumer Advisory Service - 1300 135 312. Mattel East Asia Ltd., Room 1106, South Tower, World Finance Centre, Harbour City, Tsimshatsui, HK, China. Diimport & Diedarkan Oleh: Mattel SEA Ptd Ltd.(993532-P) Lot 13.5, 13th Floor, Menara Lien Hoe, Persiaran Tropicana Golf Country Resort, 47410 PJ. Tel:03-78803817, Fax:03-78803867. Mattel U.K. Ltd., Vanwall Business Park, Maidenhead SL6 4UB. Mattel France, Parc de la Cerisaie, 1/3/5 allée des Fleurs, 94263 Fresnes Cedex. N° Cristal 0969 36 99 99 (Numero non surtaxe) ouwww.allomattel.com

W7217-0820



BATMAN and all related characters and elements are trademarks of and © DC Comics.
BATMAN et tous les personnages et les éléments y afférents sont des marques et © de DC Comics.
(s12)

service.mattel.com

INSTRUCTION SHEET SPECIFICATIONS

Toy: _____ BM
Toy No.: _____ W7217
Part No.: _____ 0820
Trim Size: _____ A5
Folded Size: _____
Type of Fold: _____
colors: _____ 1C+1C
Colors: _____ Black
Paper Stock: _____ White Offset
Paper Weight: _____ 70 lb.
EDM No.: _____