



# CARCADE™

## INSTRUCTIONS

Please keep these instructions for future reference as they contain important information.

### CONTENTS

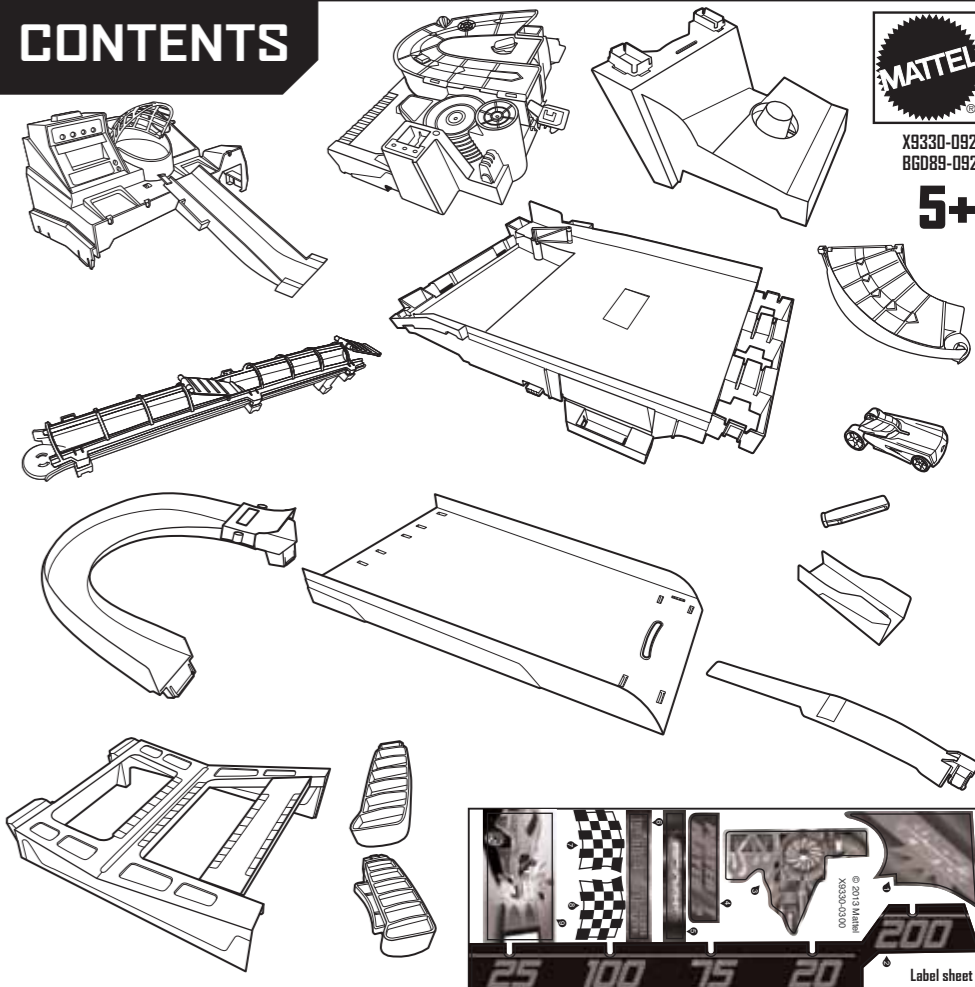

X9330-0920  
86089-0920

5+

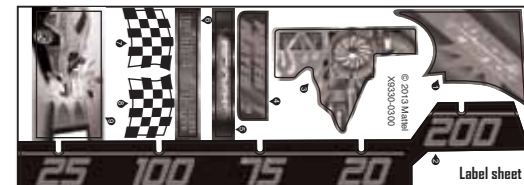

REQUIRES 3 AA(LR6) and 4 "D" SIZE (LR20) ALKALINE BATTERIES (NOT INCLUDED). DISPOSE OF BATTERIES SAFELY.

©2013 Mattel. All Rights Reserved. Mattel, Inc., 636 Girard Avenue, East Aurora, NY 14052, U.S.A. Consumer Relations 1-800-524-8697. Mattel U.K. Ltd., Vanwall Business Park, Maidenhead SL6 4UB. Helpline 01628 500303. Mattel Australia Pty., Ltd., Richmond, Victoria. 3121. Consumer Advisory Service - 1300 135 312. Mattel East Asia Ltd., Room 503-09, North Tower, World Finance Centre, Harbour City, Tsingshatsui, HK, China. Diimport & Diedarkan Oleh: Mattel SEA Ptd Ltd. (993532-P) Lot 13.5, 13th Floor, Menara Lien Hoe, Persiaran Tropicana Golf Country Resort, 47410 P.J. Malaysia. Tel:03-78803817, Fax:03-78803867. service.mattel.com

### TROUBLESHOOTING

To unblock jammed cars, turn launcher OFF (O) and remove as shown.

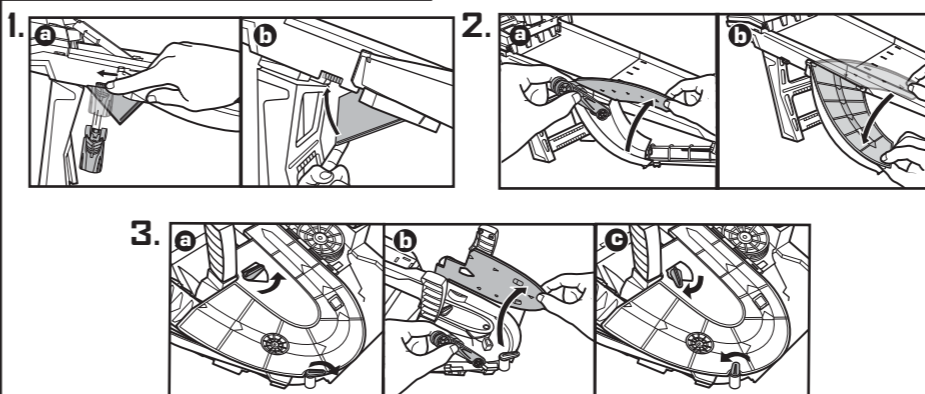

#### BATTERY SAFETY INFORMATION

In exceptional circumstances batteries may leak fluids that can cause a chemical burn injury or ruin your product. To avoid battery leakage:

- Non-rechargeable batteries are not to be recharged.
- Rechargeable batteries are to be removed from the product before being charged.
- Rechargeable batteries are only to be charged under adult supervision.
- Do not mix alkaline, standard (carbon-zinc), or rechargeable (nickel-cadmium) batteries.
- Do not mix old and new batteries.
- Only batteries of the same or equivalent type as recommended are to be used.
- Batteries are to be inserted with the correct polarity.
- Exhausted batteries are to be removed from the product.
- The supply terminals are not to be short-circuited.
- Dispose of battery(ies) safely.
- Do not dispose of this product in a fire. The batteries inside may explode or leak.

#### Battery Performance Note:

For best performance use alkaline batteries. Battery life may vary depending on battery brand.

Protect the environment by not disposing of this product with household waste (2002/96/EC). Check your local authority for recycling advice and facilities.

#### This device complies with Part 15 of the FCC Rules.

Operation is subject to the following two conditions: (1) This device may not cause harmful interference, and (2) this device must accept any interference received, including interference that may cause undesired operation.

- This equipment has been tested and found to comply with the limits for a Class B digital device, pursuant to part 15 of the FCC rules. These limits are designed to provide reasonable protection against harmful interference in a residential installation. This equipment generates, uses and can radiate radio frequency energy and, if not installed and used in accordance with the instructions, may cause harmful interference to radio communications. However, there is no guarantee that interference will not occur in a particular installation. If this equipment does cause harmful interference to radio or television reception, which can be determined by turning the equipment off and on, the user is encouraged to try to correct the interference by one or more of the following measures:
- Reorient or relocate the receiving antenna.
- Increase the separation between the equipment and receiver.
- Connect the equipment into an outlet on a circuit different from that to which the receiver is connected.
- Consult the dealer or an experienced radio/TV technician for help.

NOTE: Changes or modifications not expressly approved by the manufacturer responsible for compliance could void the user's authority to operate the equipment.

### TWO PLAYER MODE CHALLENGE A FRIEND AND COMPETE FOR THE HIGHEST SCORE!

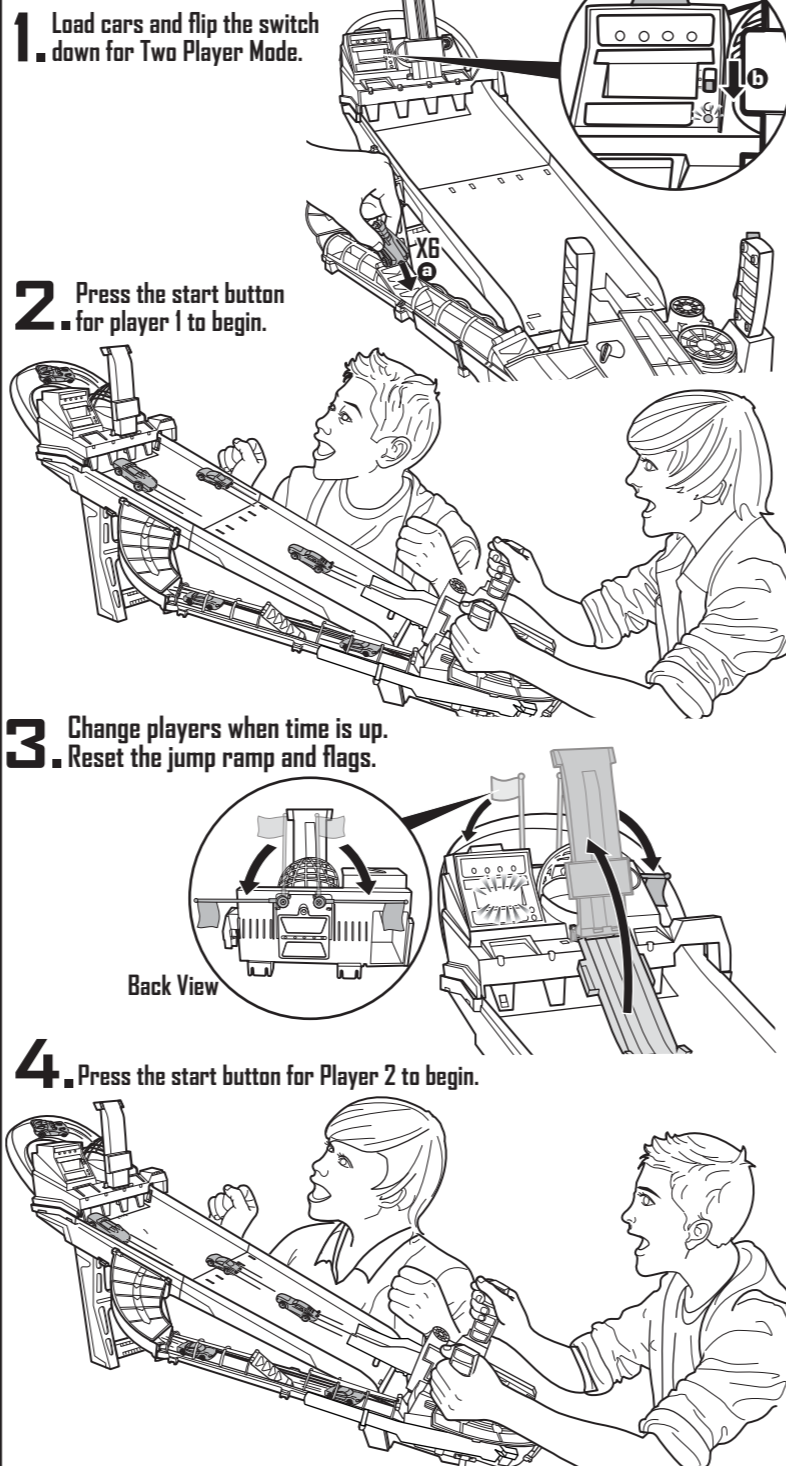

### ONE PLAYER MODE TRY TO BEAT YOUR HIGH SCORE!

2. Turn the launcher ON (I) and press the start button. You have 60 seconds to score as many points as possible!

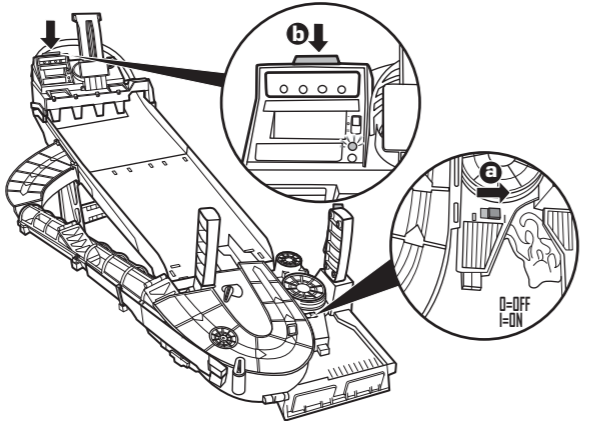

4. The "Bonus Circle" round starts after 40 seconds. Jump Ramp drops automatically.

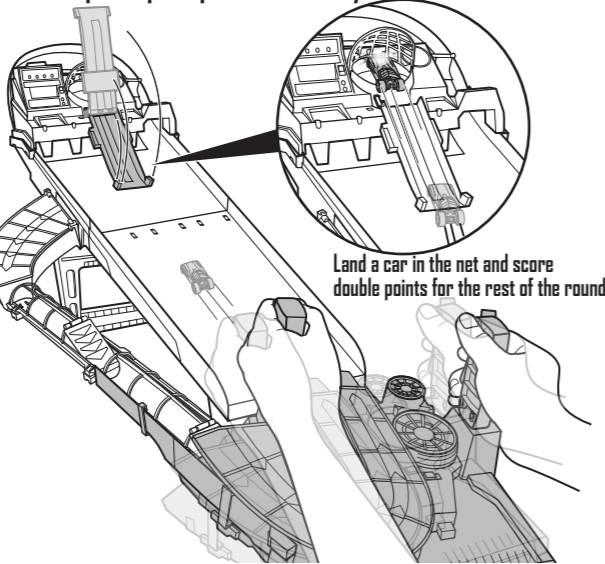

5. Check out the final score when time is up. To play again, reset jump ramp and flags, then press the start button.

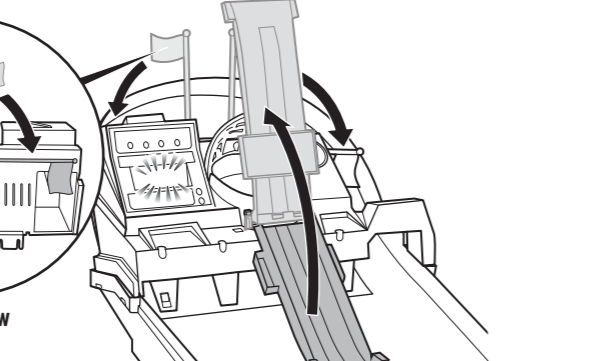

1. Load cars (maximum 6) and flip the switch up for One Player Mode.

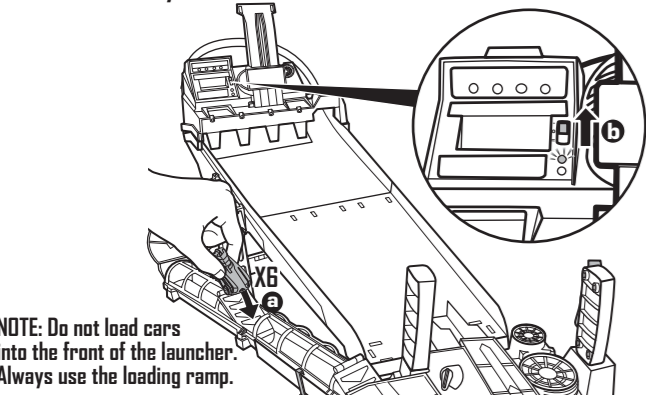

NOTE: Do not load cars into the front of the launcher. Always use the loading ramp.

3. Hit lit-up targets to score points! Targets that are not lit score no points.

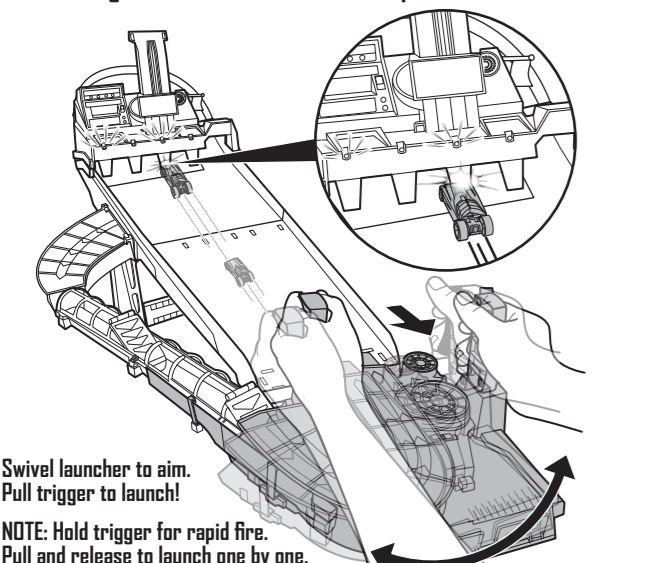

Swivel launcher to aim. Pull trigger to launch!

NOTE: Hold trigger for rapid fire. Pull and release to launch one by one.

#### IMPORTANT:

- Works best on flat, level, hard surfaces.
- To conserve battery life, the scoreboard turns off when left idle for a few minutes. To turn it back on, press the start button.
- High score resets when scoreboard batteries are removed.
- Not for use with some Hot Wheels® vehicles.



## APPLY LABELS

Helpful Hint: Apply labels before assembly by number as indicated.

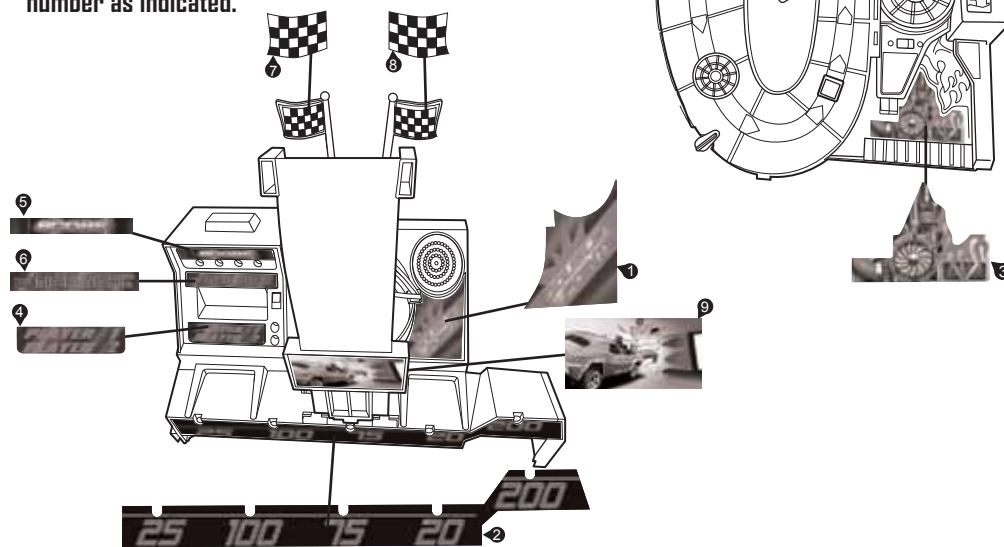

## BATTERY INSTALLATION

- Unscrew the battery cover with a Phillips head screwdriver (not included).
- Install 3AA(LRG) and 4 "D" size (LR20) alkaline batteries (not included) in the orientation (+/-) shown.
- Replace battery cover and tighten screw(s).
- For longer life use alkaline batteries.
- Replace batteries in launcher when it can no longer propel cars at targets.
- Replace batteries in scoreboard if sounds distort or lights dim.
- When exposed to an electrostatic source, the product may malfunction. To resume normal operation, remove and re-install the batteries.

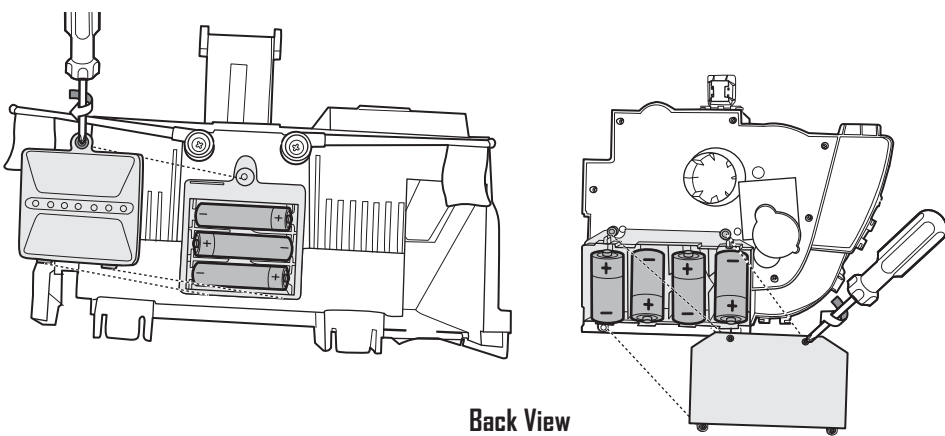

Back View

## ASSEMBLY

